



TECHNICAL MANUAL

Manual Part No. 002049
September 22, 2003



HOLE-HOG

Models

2100C & 2100C-TH

2101C & 2101C-TH

2501C & 2501C-TH

2502C & 2502C-TH

Allied Hole-Hog, Models 2100C and 2501C Series**Document Change Notice**

<u>Date</u>	<u>Page</u>	<u>Change</u>
11/05/99	17 thru 33	Updates to Disassembly and Assembly
09/22/03	Througout	Upgrade to CE Compliance and specifications
07/24/06	30	Correct Installation Tool P/N

TABLE OF CONTENTS

Section	Page
SECTION 1.0 INTRODUCTION	1
1.1 Safety Information.	1
1.2 Warranty Information.	1
1.3 Allied Product Policies.	2
SECTION 2.0 OVERVIEW	3
2.1 Body/Anvil	3
2.1.1 Plain Anvil	3
2.1.2 Threaded Anvil (TH)	3
2.1.3 Expanded Body	3
2.2 Striker	3
2.3 Tail Assembly	3
2.4 Differences Among Models Covered	3
SECTION 3.0 SPECIFICATIONS AND DECALS	5
3.1 Specifications	5
3.2 Minimum Recommended Operating Depths.	5
3.3 DECAL IDENTIFICATION.	6
SECTION 4.0 GENERAL CONSTRUCTION SAFETY	10
4.1 Owner's Responsibilities	10
4.2 General Construction Safety.	10
4.3 Federal, State, Local and OSHA Construction Guidelines and Regulations.	10
4.4 General Safety Summary	10
4.4.1 CAUTIONS and WARNINGS.	10
4.4.2 Personnel Precautions	11
SECTION 5.0 HOLE-HOG SAFETY PRECAUTIONS	12
5.1 Receiving A New Hole Hog	12
5.2 Record The Serial Number.	12
5.3 Hole-Hog Use.	12
5.4 Lifting and Blocking Precautions	12
5.5 Operating Precautions	13
SECTION 6.0 OPERATION	14
6.1 Operating Overview	14

TABLE OF CONTENTS (continued)

Section	Page
6.2 Operating Guidelines	14
6.2.1 Safety Precautions	14
6.2.2 Select a Safe Piercing Path	14
6.2.3 Prepare Entrance Trench	15
6.2.4 Prepare Exit Pit or Target	15
6.2.5 Prepare The Hole-Hog and Air Hose	15
6.2.6 Position and Aim The Hole-Hog	15
6.2.7 Piercing The Underground Hole	17
6.2.8 Reversing The Hole-Hog	18
6.2.9 Install Material in the Pierced Hole	18
6.2.10 Remove and Service Hole-Hog	18
SECTION 7.0 LUBRICATION	19
7.1 Startup	19
7.2 Normal Operation	19
7.3 De-Icing	20
SECTION 8.0 DISASSEMBLY	21
8.1 General	21
8.2 Disassembly and Assembly Tool Kit Part Number 832872.	21
8.3 Extent of Disassembly	22
8.4 Whip Hose Replacement	22
8.5 Replacing The Body/Anvil and Cap	22
8.6 Removing Tail Assembly and Striker	22
8.7 Disassembling the Tail Assembly	24
8.7.1 Remove Whip Hose and Fittings.	24
8.7.2 Remove Valve from End Cap	25
8.7.3 Remove Valve and Bushing	26
8.7.4 Disassemble End Cap Components	27
SECTION 9.0 ASSEMBLY.	29
9.1 General	29
9.2 Disassembly and Assembly Tool Kit Part Number 832872.	29

TABLE OF CONTENTS (continued)

Section	Page
9.3 Whip Hose Replacement	29
9.4 Replacing The Body/Anvil Only	30
9.4.1 Threaded Anvil (TH) Units Only	30
9.5 Assemble End Cap Components	30
9.6 Assemble Whip Hose Components.	33
9.7 Assemble Tail Assembly Components	33
9.7.1 Valve, Bushing and Valve Stem	33
9.7.2 Valve Stem, Spring, and End Cap	35
9.8 Body/Anvil, Striker and Tail Assembly.	36
9.9 Installing the Anvil Cap	38
SECTION 10.0 MAINTENANCE	39
10.1 Daily Maintenance	39
10.2 Inspection And Preventive Maintenance	39
10.3 Conditional Maintenance	39
10.4 Warranty Protection	39
SECTION 11.0 FIELD MAINTENANCE	40
11.1 Field Replacement of the Whip Hose.	40
11.1.1 Remove Old Whip Hose.	40
11.1.2 Install New Whip Hose Assembly	41
11.2 Hole-Hog Accessories	41
11.3 Installing Nose Covers and Expanders	42
11.3.1 Models without Anvil Cap	42
11.3.2 Models with Anvil Cap	42
SECTION 12.0 HOLE-HOG TROUBLESHOOTING CHART	43
SECTION 13.0 HOLE-HOG STORAGE	44
13.1 Short Term Field Storage.	44
13.2 Long Term Storage	44
SECTION 14.0 PARTS & WARRANTY INFORMATION	45

LIST OF FIGURES

Figure	Page
Decal - Read Technical Manual.	6
Decal - Made in USA.	6
Decal - Hole-Hog Patent Numbers.	8
Decal - ALLIED LOGO	8
Decal - Hole-Hog CE Serial Number Plate	9
Figure 3-1. Hole-Hog Decal Location	9
Figure 6-1. Lifting the Hole-Hog.	17
Figure 8-1. Hole-Hog Tool Kit	22
Figure 8-2. Loosening the End Cap	23
Figure 8-3. Removing the Tail Assembly	24
Figure 8-4. Access The Striker With a Long Hook.	24
Figure 8-5. Tilting the Body/Anvil to Access the Striker	24
Figure 8-6. Striker Removed from Body/Anvil.	24
Figure 8-7. Remove Whip Hose.	25
Figure 8-8. Remove Coupling Socket from Whip Hose.	25
Figure 8-9. Remove Gasket from Coupling Socket.	25
Figure 8-10. End Cap In Vise with Set Screw Accessible	26
Figure 8-11. Thread Valve Stem from Adapter.	26
Figure 8-12. Valve Stem Components Removed from End Cap.	26
Figure 8-13. Valve Stem and Components in Arbor Press.	27
Figure 8-14. Remove the Valve from the Assembled Valve Stem and Bushing.	27
Figure 8-15. Remove the Valve Bushing from the Valve Stem.	27
Figure 8-16. Removing The Valve Seal from The End Cap	28
Figure 8-17. Insert Valve Guide Tool.	28
Figure 8-18. Press Out Valve Guide.	28
Figure 8-19. Cutting Pattern for Shock Absorber.	29
Figure 9-1. End Cap, Tool 832870 and Shock Absorber.	31
Figure 9-2. Press the Shock Absorber into the End Cap.	31
Figure 9-3. Shock Absorber in End Cap	32
Figure 9-4. Seat the Shock Absorber in the End Cap.	32
Figure 9-5. Prepare Valve Guide for Installation into the Shock Absorber.	32

LIST OF FIGURES

Figure	Page
Figure 9-6. Press the Valve Guide into The Shock Absorber..	33
Figure 9-7. Press Valve Seal into End Cap and onto Valve Guide.	33
Figure 9-8. Insert New Gasket in Q.D. Socket.	34
Figure 9-9. Apply Teflon Tape to Hose Fitting.	34
Figure 9-10. Secure Whip Hose to Q.D. Socket.	34
Figure 9-11. Lubricate End of Valve Stem.	35
Figure 9-12. Install Bushing on Valve Stem.	35
Figure 9-13. Install Valve on Bushing..	35
Figure 9-14. Valve Pressing Tool on Valve	35
Figure 9-15. Press Valve onto Bushing and Valve Stem.	36
Figure 9-16. Slide Spring onto Valve Stem.	36
Figure 9-17. Slide Valve Stem and Spring into End Cap and Valve Guide.	36
Figure 9-18. Valve Stem Threads	36
Figure 9-19. Valve Stem and Adapter	36
Figure 9-20. Secure Valve Stem to Adapter	37
Figure 9-21. Tighten Set Screw.	37
Figure 9-22. Apply Teflon Tape to Hose Fitting.	37
Figure 9-23. Secure Whip Hose To Adapter.	37
Figure 9-24. Slide Striker into Body/Anvil.	38
Figure 9-25. Prepare Tail Assembly and Body/Anvil for Assembly.	38
Figure 9-26. Insert Valve into Striker..	38
Figure 9-27. Fasten End Cap to Body/Anvil	38
Figure 9-28. Tighten the End Cap to the Required Torque	38
Figure 9-29. Secure Anvil Cap to Body/Anvil	39
Figure 9-30. Tighten the Anvil Cap to the Required Torque	39
Figure 11-1. Remove Whip Hose from Adapter..	41
Figure 11-2. Remove Whip Hose from Q.D. Socket	41
Figure 11-3. Remove Q.D. Gasket	41
Figure 11-4. Insert Q.D. Gasket into Q.D. Socket.	42
Figure 11-5. Apply Teflon Tape to Hose Fitting.	42

LIST OF FIGURES

Figure	Page
Figure 14-1. Model 2100C Hole-Hog Complete Assembly	47
Figure 14-2. Model 2100C-TH Hole-Hog Complete Assembly	49
Figure 14-3. Model 2101C Hole-Hog Complete Assembly	51
Figure 14-4. Model 2101C -TH Hole-Hog Complete Assembly	53
Figure 14-5. Model 2501C Hole-Hog Complete Assembly	55
Figure 14-6. Model 2501C-TH Hole-Hog Complete Assembly	57
Figure 14-7. Model 2502C Hole-Hog Complete Assembly	59
Figure 14-8. Model 2501C-TH Hole-Hog Complete Assembly	61
Figure 14-9. Air Line Lubricator Assembly	63

SECTION 1.0 INTRODUCTION

Hole-Hog Technical Manual: Part Number 002049

This Technical Manual is applicable to Hole-Hog:

Models: 2100C, 2100C-TH
 2101C, 2101C-TH
 2501C, 2501C-TH
 2502C, 2502C-TH

Years of Manufacture: 19?? and beyond

Serial Number(s) _____

The model and serial numbers are located on the ID Plate mounted on the Hole-Hog as shown in Section 3.3 Decal Identification. The serial number is also stamped on the striker.

This manual contains important information for the safe use and maintenance of the Allied Hole-Hog. Read this manual thoroughly before installing, operating or servicing the Hole-Hog. This manual must be easily accessible to operators or service and transport personnel. Store this manual in a convenient location.

Pay careful attention to all instructions and follow all governing regulations. Operation or service other than in accordance with these instructions may subject the Hole-Hog to conditions beyond its design capability. Improper operation, service or the use of non-Allied parts may result in Hole-Hog failure or personnel injury.

1.1 Safety Information

When using the Hole-Hog, underground safety procedures such as the location of existing underground service lines, cables and conduit must be followed. See Sections 4.0 and 5.0 for further safety guidelines.

Pay particular attention to WARNINGS and CAUTIONS, identified with this symbol.



These instructions are important for personnel safety and full service life of the Hole-Hog. Follow them carefully.

1.2 Warranty Information

Warranty coverage of the Allied Hole-Hog, depends on proper maintenance and operation of the Hole-Hog as detailed in this manual. Improper maintenance or operation shall void Hole-Hog warranty coverage. Immediately upon receipt of the Hole-Hog, read all Allied warranty documents delivered with the unit for a thorough understanding of warranty coverage.

Record the Hole-Hog Serial Number in the space provided above.

1.3 Allied Product Policies

Allied reserves the right to make modifications to the design or changes to the specifications without prior notice.

In this manual, Allied recommends Hole-Hog applications, maintenance and service consistent with industry practices. Allied takes no responsibility for the results of actions not recommended in this manual and specifically the results of:

- Operation in non-recommended applications
- Incorrect operation
- Improper maintenance
- Use of service parts not approved or supplied by Allied.

These exclusions apply to damage to the Hole-Hog, associated equipment, and injury to personnel.

SECTION 2.0 OVERVIEW

The Allied 2100C Series Hole-Hog is a pneumatically propelled, reversible, ground piercing tool designed to pierce continuous, blind horizontal, inclined and vertical holes in compressible soils. With optional attachments, the Hole-Hog can also be used to install or remove rigid pipe from the ground.

The tool consists of three primary sections: Body/Anvil, Striker and Tail Assembly. A simple reversing mechanism allows the operator to easily change the tool's direction from forward to reverse.

2.1 Body/Anvil

The body/anvil forms the majority of the Hole-Hog's exterior. It consists of the anvil and the body. Refer to Figure 2-1. The body/anvil is the ground contact surface. Wear of this component is expected and normal. The body is internally threaded at the rear for attaching the Tail Assembly.

2.1.1 Plain Anvil

The models with plain anvils are: 2100C, 2101C, 2501C and 2502C. See Table 2-1 and Figure 2-1.

The anvil is the conical surface that forms the front of the body/anvil. The anvil is pressed into the body, and cannot be removed from the assembled body/anvil.

2.1.2 Threaded Anvil (TH)

The models with threaded anvils are: 2100C-TH, 2101C-TH, 2501C-TH and 2502C-TH. As you may note, the model number suffix **-TH** indicates a model with the threaded anvil feature. See Table 2-1 and Figure 2-1.

The threaded anvil feature enables the mounting of optional accessories that enhance operation of the Hole-Hog. Refer to Section 11.0 for more information on accessories and their functions. The anvil cap protects the anvil threads.

2.1.3 Expanded Body

As shown in Figure 2-1, some Hole-Hogs have expanded bodies. These models pierce a larger diameter hole through the ground. The smaller portion of the body pierces a pilot hole and the larger portion of the body expands the hole.

2.2 Striker

The striker is moved by air pressure back and forth within the body. Internally, the striker impacts either the anvil at the front or the tail assembly at the rear to propel the Hole-Hog through the ground.

2.3 Tail Assembly

Except for the Striker, the Tail Assembly contains all internal operating components, including the reversing mechanism. The external threads of the End Cap secure the Tail Assembly to the Body/Anvil. The Whip Hose attaches to the Tail Assembly at the other end of the End Cap. Hole-Hog service and repair require removal of the tail assembly to access the serviceable parts.

2.4 Differences Among Models Covered

This manual covers eight Allied Hole-Hog Models, as listed in Table 2-1.

All information in this manual applies to all eight models unless specifically noted

otherwise. These eight models are identical except for two features:

- Some models have Threaded Anvils.
- Some models have Expanded Bodies.

Table 2-1 lists all of the models covered in this manual and the differences among those models.

DIFFERENCES AMONG MODELS COVERED			
Model	Threaded Anvil	Expanded Body	Config.
2100C	NO	NO	A
2100C-TH	YES	NO	B
2101C	NO	YES	C
2101C-TH	YES	YES	D
2501C	NO	NO	A
2501C-TH	YES	NO	B
2502C	NO	YES	C
2502C-TH	YES	YES	D

SECTION 3.0 SPECIFICATIONS AND DECALS

3.1 Specifications

Outside Diameter:

- 2100C & 2100C-TH . . . 3-7/8 in. (98mm)
- 2101C & 2101C-TH 5 in. (127mm)
- 2501C & 2501C-TH . 4-1/16 in. (103mm)
- 2502C & 2502C-TH. . . . 6 in. (152mm)

Weight:

- 2100C & 2100C-TH . . . 125 lbs. (57kg)
- 2101C & 2101C-TH . . . 142 lbs. (64kg)
- 2501C & 2501C-TH . . 140 lbs. (63.5kg)
- 2502C & 2502C-TH . . . 164 lbs. (74kg)

Overall Length: 62 in. (1575mm)

Operating Air PSI *: 95 psi (6.3 kg./cm²)

Air Consumption/Min.: . 60 cfm (.1.7m³)

Whip Hose

(inside diameter): 1 in. (25mm)

Recommend Delivery Hose

(inside diameter):.1 in. (25 mm)

Percussion Rate Per Minute: 400

* Pressure required at the tool. Allow 5 psi (0.4 kg/cm²) pressure drop for each 100 ft. (30m) of hose. Pressure above 100 psi (7 kg./cm²) at the tool decreases the life of the Hole-Hog.

3.2 Minimum Recommended Operating Depths

- Hard Glacial Clay 18 in.
- Clay/Sand Mix 18 in.
- Wet/Dry Sand 24 in.
- Cultivated Soil 24 in.
- Clay/Loam Mix 20 in.

The Hole-Hog operates best in compactable soils. The minimum depth of operation varies with soil conditions and the length of the hole. The chart above is intended as a guide only. Specifications subject to change without notice.

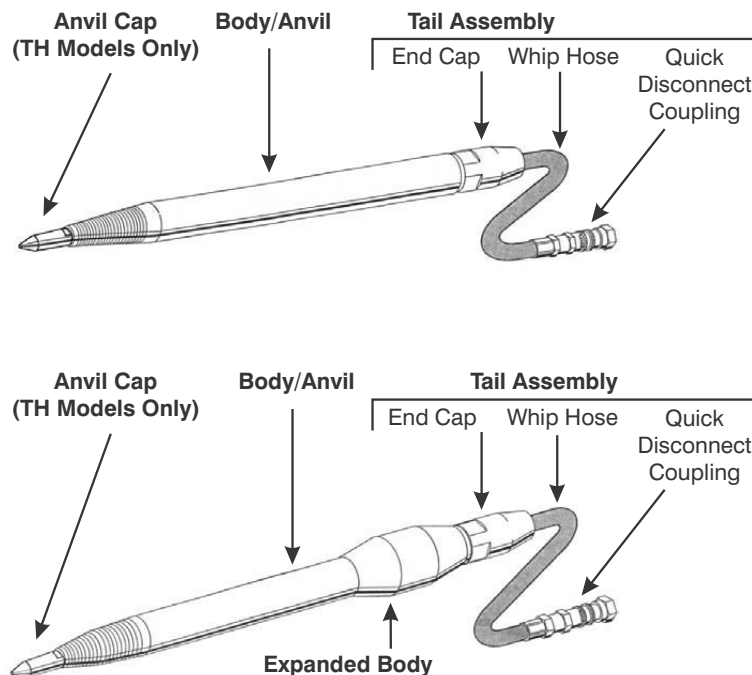
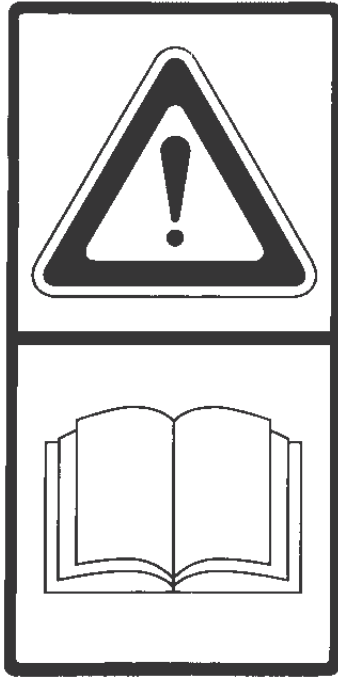

Figure 3-1.Hole-Hog Major Components

3.3 DECAL IDENTIFICATION

IMPORTANT! Read Technical Manual.
Follow Instructions, Cautions and Warnings.



Made in USA

U.S. PATENT NUMBERS

4,662,457	3,410,354
4,809,789	3,756,328

OTHERS PENDING

833291

Hole-Hog Patent Numbers.



The ALLIED LOGO decal is the Allied brand identifier and is a registered trademark of Allied Construction Products, LLC

Hole-Hog[®]

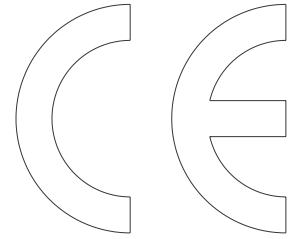

Model:
Year:

Serial Number:
Mass (kg):



3900 Kelley Avenue, Cleveland, Ohio 44114 USA

Hole-Hog CE Serial Number Plate

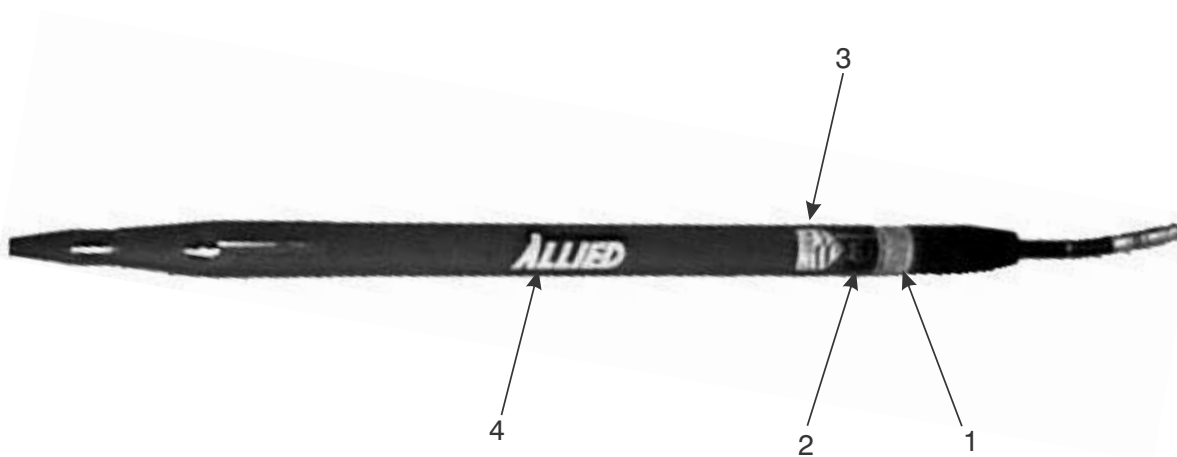

Figure 3-1. Hole-Hog Decal Location

Hole-Hog Decal Kit Part No. 833295			
ITEM NO.	QTY.	PART NO.	DESCRIPTION
1	1	676984	Decal - Read Instructions
2	1	833291	Decal - Hole-Hog Patents
3	1	815696	Decal - Made in USA

SECTION 4.0 GENERAL CONSTRUCTION SAFETY

4.1 Owner’s Responsibilities

The equipment owner shall:

- Provide this technical manual to the Hole-Hog operators.
- Train all operating personnel and enforce the procedures explained in this manual, especially regarding safety to personnel and equipment.
- Adapt these general instructions to specific applications.

4.2 General Construction Safety

Follow standard safety precautions expected and required of those working in construction, including but not limited to: locating existing underground service and utility lines, establishing pedestrian barriers and using personnel protection equipment, etc.

4.3 Federal, State, Local and OSHA Construction Guidelines and Regulations

Use the Hole-Hog in accordance with all federal, state and local regulations regarding construction practices and public safety. Identification of, and compliance to, governing regulations are the responsibility of the owner and operator.

In the United States, comply with the recommendations of the Occupational Safety and Health Administration standards of the U.S. Department of Labor. For OSHA construction guidelines contact your local federal government office or write:

U.S. Government Printing Office
 Superintendent of Documents
 P.O. Box 371954
 Pittsburgh, Pa. 15250

Ask for Construction Industry OSHA Standards Stock #869-034-00107-6.

4.4 General Safety Summary

The safe and effective use of any heavy construction equipment depends upon proper installation, operation, maintenance and repair. Operational safety must encompass all of these factors. Section 5.0 includes minimum safety policies the Hole-Hog owner shall establish for all Hole-Hog installations. The operational safety program must be tailored by the Hole-Hog owner to the specific site and application. Such a program will result in increased equipment life and performance and reduced downtime. Most importantly, it will reduce the risk of equipment damage and personnel injuries.

4.4.1 CAUTIONS and WARNINGS.

Throughout this manual detailed CAUTIONS and WARNINGS are included with the instructions and procedures. Even experienced service technicians are to review these CAUTIONS and WARNINGS prior to performing a procedure. These are highlighted by the symbol shown here.



**WARNING**

Instructions preceded by this symbol identify hazards to personnel. WARNING instructions must be followed to ensure safe handling and operation. These instructions shall be followed at all times. Improper operation or servicing can result in personal injury. Read this manual thoroughly before operating or maintaining the Hole-Hog.

**CAUTION**

Instructions identified with this symbol are important to prevent damage to equipment and to maintain full service life of the Hole-Hog. Follow them carefully. Operation or service not in accordance with these instructions may subject the Hole-Hog to conditions beyond its design capability. Read this manual thoroughly before operating or maintaining the Hole-Hog.

4.4.2 Personnel Precautions

- Always wear safety glasses and protective clothing when operating or handling the Hole-Hog.
- All personnel in the immediate area must wear ear protection.

SECTION 5.0 HOLE-HOG SAFETY PRECAUTIONS

5.1 Receiving A New Hole Hog

The Hole-Hog is delivered assembled, lubricated, and factory tested. Inspect for possible shipping damage. Pay particular attention to the hose.



WARNING

Ensure that the End Cap is properly tightened. A loose End Cap could blow out with damaging force causing injury to the operator and bystanders. Before operation, check the tightness of the end cap using the proper tools and torque (Section 9.13, Steps 10, 11, and 12).



CAUTION

If the end cap becomes loose at any time, do not retighten. Remove end cap and clean thoroughly. Pay special attention to cleaning the threads of end cap and body. Lubricate threads as instructed in the maintenance section, then re-assemble according to Section 9.8

It is recommended that the air hose be connected to an air compressor of sufficient capacity and the Hole-Hog operated above ground momentarily.

5.2 Record The Serial Number

Upon receipt of the Hole-Hog, record the Serial Number, as listed on the shipping

papers, in the space provided in Section 3.1.

5.3 Hole-Hog Use

The Allied Hole-Hog is an underground peircing tool used to pierce underground holes and to drive pipe. Do not use the Hole-Hog in any manner not described in this manual. Personal injury may result from improper use of the Hole-Hog.

5.4 Lifting and Blocking Precautions

Each of the Hole-Hog Models covered in this manual are heavy; refer to Section 3.0 Specifications. Even when disassembled, component parts like the Body/Anvil and Striker are heavy enough to cause serious bodily injury if not handled with caution.

When handling and lifting these Hole-Hogs, follow all precautions normal to the lifting and operating of heavy equipment with particular attention to the following.

- Always use sufficient blocking to prevent accidental or sudden movement of the Hole-Hog or its components.
- Always prevent the Hole-Hog and/or its components from rolling when they are placed on a horizontal surface.
- Always use suitable lifting equipment that will assure the safety of personnel and not damage the Hole-Hog or its components.
- Any unit over 88 pounds (40kg) cannot be lifted manually. Use slings on either end of the Hole-Hog as shown in Figure 6-1 to lift the Hole-Hog in and out of the

trench.

- Always wear gloves and keep hands and feet away from pinch points.
- Hole-Hog surface may be extremely hot or cold. Always wear gloves or burns may result.
- Always wear a hard-hat when any part of the Hole-Hog will be lifted above waist level.
- When manually handling the Hole-Hog or its components, make sure enough personnel are used to safely distribute the strain among them. Make sure they are wearing the following safety items.
 - Steel-toed shoes suitable to protect the arch as well as the toes.
 - Kidney belt wide enough and tight enough to protect against herniating internal organs and lower back.

5.5 Operating Precautions

- Daily, before operation, check the tightness of the end cap using the proper tools and tightening method as described in Section 9.8, Step 8. A loose end cap could blow out with damaging force, injuring the operator or bystanders.
- Daily, before operation, check the tightness of the anvil cap on models with a threaded anvil; refer to Section 9.9.
- Observe all safety precautions outlined in the air compressor operating manual.
- The owner/operator/contractor is responsible for locating underground utili-

ties.

- Do not attempt to pierce a hole in frozen ground.
- Entrance and exit pits may be unstable and dangerous. These trenches must be shored to meet federal, state and local guidelines. Allied's TrenShore is recommended.
- The work site must be properly illuminated to provide enough light to work safely.
- There shall be a safety person at the compressor to shut the unit down in case of emergency. The operator and safety person shall have agreed upon hand signals to indicate the necessity of immediate shut down.
- Be aware of Hole-Hog travel distance by marking air supply hose. Place marking tape at two foot intervals on the hose to monitor travel.
- Check air supply hose periodically for fitting and hose damage.
- Serious injury from flying debris may result if personnel are in line with the Hole-Hog exhaust. Stand clear.
- Never stand directly over the Hole-Hog air supply hose. Retain hoses to protect against whipping in case of failure.
- Never pull on whip hose or air compressor hose to move or position Hole-Hog. Injury could result from broken or separated hoses.

SECTION 6.0 OPERATION

6.1 Operating Overview

There are 9 steps in piercing an underground hole with a Hole-Hog :

- Review all safety precautions.
- Select a safe path for the hole to be pierced.
- Dig an entrance pit at one end of the path.
- Dig an exit pit or set a target marker at the other end of the path.
- Prepare the Hole-Hog and air supply lines.
- Place the Hole-Hog in the entrance pit and align it with the target or exit hole.
- Operate the Hole-Hog until it completes the hole.
- Remove the Hole-Hog.
- Install material into the pierced hole.

6.2 Operating Guidelines

When performing each of the the steps listed in 6.1, pay particular attention to the related guidelines below.

6.2.1 Safety Precautions

Review the safety sections, 4.0 and 5.0, of this manual. Perform all operations according to the precautions and recommendations described in these sections.

	<p>WARNING</p> <p>Use extreme caution working with electric and gas lines. Cutting a utility line could cause serious injury or death.</p>
---	---

6.2.2 Select a Safe Piercing Path

Plan and mark the complete piercing path and the depth of the hole prior to starting Hole-Hog operation.

1. Locate all utility lines: water, electric, gas and sewer lines, in the area to be penetrated.
2. Select the shortest possible path under the obstacle (road, walk, driveway, etc.).
3. Determine the depth (elevation) of the hole to be pierced.
 - a. Refer to 3.2 Minimum Recommended Operating Depths.
 - b. Identify the type of soil to be pierced and the minimum depth of the hole.
 - c. If possible, select a hole depth well below the minimum. In some soils, the Hole-Hog may raise while piercing a shallow hole.
 - d. When the piercing path is very long through low density soil, the hole depth should be as deep as practical for the application.
 - e. Do not attempt to pierce a hole through frozen ground. However, a hole can be peirced under the frost line.

6.2.3 Prepare Entrance Trench



WARNING

Entrance and exit trenches may be unstable and dangerous. These trenches must be shored to meet federal, state and local guidelines or injury to personnel could occur.

Excavate the entrance trench to the depth, width and length required to properly align the piercing tool and work comfortably. Shore entrance trench to meet safety guidelines. Allied’s TrenShore is recommended.

Trench length should:

- Allow enough room for the operator to push the Hole-Hog into the wall to be pierced, approximately one foot beyond the end of the whip hose.
- Permit a soft bend in the Whip Hose. Do not crimp the air supply.

6.2.4 Prepare Exit Pit or Target

Excavate the exit pit. The length, width, and depth of the exit pit should exceed the entrance pit dimensions by 6 in. to 10 in./152mm to 254mm.

In cases where the exit pit length is limited and for blind holes, the unit is reversed and drives itself back out through the pierced hole.

6.2.5 Prepare The Hole-Hog and Air Hose

1. Refer to Section 10.0 Maintenance and perform Daily and Preventive Maintenance.
- 2.

Review all of Section 7.0 Lubrication. Startup Lubrication, paragraph 7.1 must performed at the beginning of piercing operations, paragraph 6.2.7

3. To monitor Hole-Hog travel along the piercing path, mark the air hose in two ways.
 - a. Place tape at two foot intervals along the hose.

This provides an indication of how far the Hole-Hog has traveled along the path.

- b. Measure the total length of the piercing path. Measure that length from the piercing tip, back along the Hole-Hog and hose. Make a special tape mark at that point.

This provides an indication of when the piercing tool should reach the exit point. It will also indicate if the tool has been deflected off course.

4. For the TH models only: verify that the Anvil Cap or other required tool is secured to the threaded anvil.
5. Connect air supply hose to compressed air supply and purge air hose.

6.2.6 Position and Aim The Hole-Hog

1. Verify that the bottom of the entrance pit is at the depth (elevation) determined in 6.2.2, step 3.



WARNING

Do not manually lift any unit over 88 pounds (40kg). Use slings on either end of the Hole-Hog to lift the Hole-Hog in and out of the trench.

 **WARNING**
Do not stand under Hole-Hog being lowered into trench. The Hole-Hog could fall and cause serious injury or death.

- Lower the Hole-Hog into the entrance trench with slings, as shown in Figure 6-1., with the piercing tip just touching the wall to be pierced.

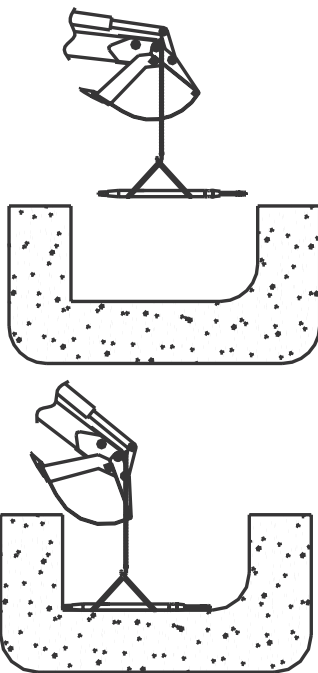



Figure 6-1. Lifting the Hole-Hog

- Align the length of the Hole-Hog with the center of the exit pit or target at the other end of the piercing path.
- The nose of the tool must be pitched down to compensate for a tendency of the tool to raise along the path.

The amount of pitch depends on the length of travel and the soil type. Normally one half a bubble on a construction level is sufficient.

- Block the Hole-Hog in this position.

 **WARNING**
Always wear safety glasses, gloves and protective clothing when operating or handling the Hole-Hog to prevent injury from flying debris.

 **WARNING**
All personnel in the immediate area must wear ear protection to protect the ears from the noise of the compressor and the Hole-Hog.

 **WARNING**
Do not stand in the Hole-Hog exhaust. Serious injury from flying debris may result. Stand clear.

 **WARNING**
Do not stand behind Hole-Hog. If an obstruction is hit, the unit could kick back and cause serious injury.

 **WARNING**
Never pull on whip hose or air supply hose. Serious injury could result if hoses break or separate.

 **WARNING**
Hole-Hog surface may be extremely hot or cold. Always wear gloves or burns may result.

6.2.7 Piercing The Underground Hole

1. To “wet” the air line, pour a small amount of Allied Hog Wash into air line at the compressor connection and connect it to piercing tool air line.(Refer to Section 7.0 Lubrication.)
2. Quickly turn on the air supply and immediately reduce air pressure to approximately 2/3 of full open and start piercing tool penetration into the ground. It is necessary to apply force in the direction of motion.
3. After approximately 1/3 of the body length has penetrated into the forward wall of the entrance pit, check alignment on target and pitch using suitable level. Refer to paragraph 6.2.6, step 4 for the proper pitch.
4. Restart air supply to piercing tool. If tool fails to start, simply open and close the quick-acting valve to create pulses of air to start the tool.
5. Continue checking alignment and pitch (steps 3 and 4) until the Hole-Hog is completely enveloped by the forward wall of the entrance pit.
6. Increase air pressure to 100 psi (7.0kg/cm²) and complete hole penetration. Never exceed 100 psi (7.0kg/cm²). Pressures above 100 psi (7.0kg/cm²) decrease tool life.
7. Monitor Hole-Hog progress along the piercing path. Use the 2-foot tape markers on the air hose to estimate the length of hose used and progress along the path.
8. The Hole-Hog can be stopped or deflected from its path by some underground obstacles.
 - If the Hole-Hog stops moving along the path, it has hit an obstacle.

- If total path marker on the air hose is reached but the Hole-Hog has not reached the target or exit pit, the Hole-Hog has been deflected by an obstacle.

In either case:

- a. Retrieve the Hole-Hog by reversing Hole-Hog direction as described in paragraph 6.2.8.



WARNING

Use extreme caution working with electric and gas lines. Cutting a utility line could cause serious injury or death

Verify location of all utilities before starting a second hole.

- b. Pierce another hole that will bypass the object, repeating steps 6.2.6 and 6.2.7. In extreme circumstances it may be necessary to relocate the entrance or exit pit.
9. When the Hole-Hog reaches the exit pit or target, stop compressed air delivery by closing the air supply valve.

DO NOT REMOVE THE HOLE-HOG from the exit pit or pierced hole.
10. Before removing the Hole-Hog from the exit pit or pierced hole, verify the means by which the pipe, tube, cable, etc. will be installed in the pierced hole.

Refer to paragraph 6.2.9 Install Material in the Pierced Hole.



CAUTION

If the end cap becomes loose at any time, do not retighten. Remove end cap and clean thoroughly. Pay special attention to cleaning the threads of end cap and body. Lubricate threads as instructed in the maintenance section, then re-assemble according to Section 9.8.

6.2.8 Reversing The Hole-Hog

If the Hole-Hog meets an obstacle or deviates from course, stop the tool and reverse it out of the hole. The tool may also be stopped and returned when a blind hole is required.

To reverse the tool, proceed as follows:

1. Stop compressed air delivery by closing the air supply valve.



CAUTION

Do not pull on the air hose or use hose as a handle. This could damage internal components.

2. With the air supply off, rotate hose assembly 120 degrees counterclockwise. The hose may need to be turned several times to account for hose twist.
3. Open the air supply valve and verify that the tool is in reverse mode.
4. Increase air pressure to 100 psi (7.0kg/cm²) and drive the tool out of the hole. Never exceed 100 psi (7.0kg/cm²). Pressures above 100 psi (7.0kg/cm²) decrease tool life.

6.2.9 Install Material in the Pierced Hole

Many attachments are available for the Hole-Hog. Some of these install materials in the pierced hole; for example: pipe drivers and cable /tube pullers.

If one of these attachments is used to install material in the pierced hole:

1. Refer to the manual provided with the attachment and proceed as instructed.
2. Once the material is installed in the pierced hole, remove and service the Hole-Hog as described in 6.2.10.

6.2.10 Remove and Service Hole-Hog

1. When the Hole-Hog is no longer required for piercing or material installation, proceed as follows:
 - a. Stop compressed air delivery by closing the air supply valve.
 - b. Disconnect the hose and remove the hose from the hole.





WARNING

Any unit over 88 pounds (40kg) shall not be lifted manually. Use slings on either end of the Hole-Hog as shown in Figure 6-1. to lift the Hole-Hog out of the trench.

- c. Remove the tool from the pit.
2. Clean all mud and other debris from the Hole-Hog. Refer to Section 10.0 Maintenance and perform appropriate procedures.

SECTION 7.0 LUBRICATION

 **WARNING**
 Always read and follow lubricant safety precautions. Lubricant is harmful if breathed or swallowed and could cause illness or death. Use caution when applying lubricant.

 **WARNING**
 Never use flammable lubricants or in-line cleaners. Explosion and fire could result causing serious personal injury. Flammable lubricants can damage Hole-Hog parts.

- At temperatures below 40°F (5°C): 5 to 7 drops per minute.
- At temperatures above 40°F (5°C): 3 to 5 drops per minute.

After several minutes of operation at the proper lubricant rate, the whip hose should be lightly coated with lubricant. If a heavy mist of lubricant is continuously present in the exhaust air, the lubrication rate is too great. Adjust the lubrication rate accordingly.

To insure proper operation and tool life, the Hole-Hog must be lubricated during use. Allied recommends the use of Allied Hog Wash lubricant or equivalent and de-icing agent dispensed by the Allied Air Line Lubricator. At temperatures below 60°F (15°C), the use of a lubricator and de-icing agent is recommended.

7.1 Startup

Just prior to operation, purge the supply hose of any debris and water. Next, pour approximately 2 ounces (60cc) of Allied Hog Wash into the hose at the compressor and at every 100 ft. (30m) interval. This wets the hose and ensures that lubricant flows into the Hole-Hog. An initial heavy mist of lubricant in the exhaust air may be experienced upon tool startup.

7.2 Normal Operation

During normal Hole-Hog operation, dispense lubricant at the following rate:

7.3 De-Icing

Because the tool is powered by expanding compressed air, a normal cooling effect inside the tool is experienced. Under certain temperature and humidity conditions, the moisture in the compressed air can condense and freeze on internal components. The weather conditions of cool, damp days are ideal for icing problems to develop.

Icing problems can be minimized by conditioning (heating or drying) the compressed air prior to delivery to the Hole-Hog. Consult the air compressor manufacturer for the availability of these accessories.

An early indicator of internal icing is the presence of ice chips in the air exhaust. Excessive icing restricts striker movement which results in erratic or non-performance.

If internal ice buildup is suspected:

1. Stop the air delivery to the tool.
2. Wait several minutes to allow the tool to warm.
3. Prior to restarting the tool, follow the instructions in Section 7.1. This step may need to be repeated if icing is severe.
4. If icing persists, increase the amount of lubricant delivered to the Hole-Hog. The use of a lubricant with a de-icing agent is extremely important under these conditions. Allied Hog Wash is recommended.

SECTION 8.0 DISASSEMBLY



WARNING

Do not remove the End Cap from the Body/Anvil under field operating conditions. This may expose the internal operating parts to contamination, and reduce the operating life of the Hole-Hog.

8.1 General

The procedures in this section must be performed in a machine shop suitable for the disassembly, cleaning, inspection and repair of pneumatic construction equipment. In addition to the tools and fixtures normally stocked in such a shop, the Allied Tool Kit 832872 must also be available.

In the following procedures, reference numbers in parentheses accompany most part names. These numbers refer to the part item numbers on the exploded views and parts lists in Section 13.0.

**8.2 Disassembly and Assembly Tool Kit
Part Number 832872**

The tools contained in this kit are listed below and illustrated in Figure 8-1.

1. Shock Absorber Installation Tool; P/N 832870, quantity 1.
2. First Stage Shock Absorber Pusher; P/N 831876, quantity 1.
3. Second Stage Shock Absorber Pusher Tool, P/N 832873, quantity 1.
4. Valve Seal Installation Tool, P/N 832874, quantity 1.
5. Valve Guide Installation Tool, P/N 832871, quantity 1.
6. End Cap Wrench, P/N 832817, quantity 1.
7. Valve Guide Installation Tool Pusher, P/N 832877, quantity 1.

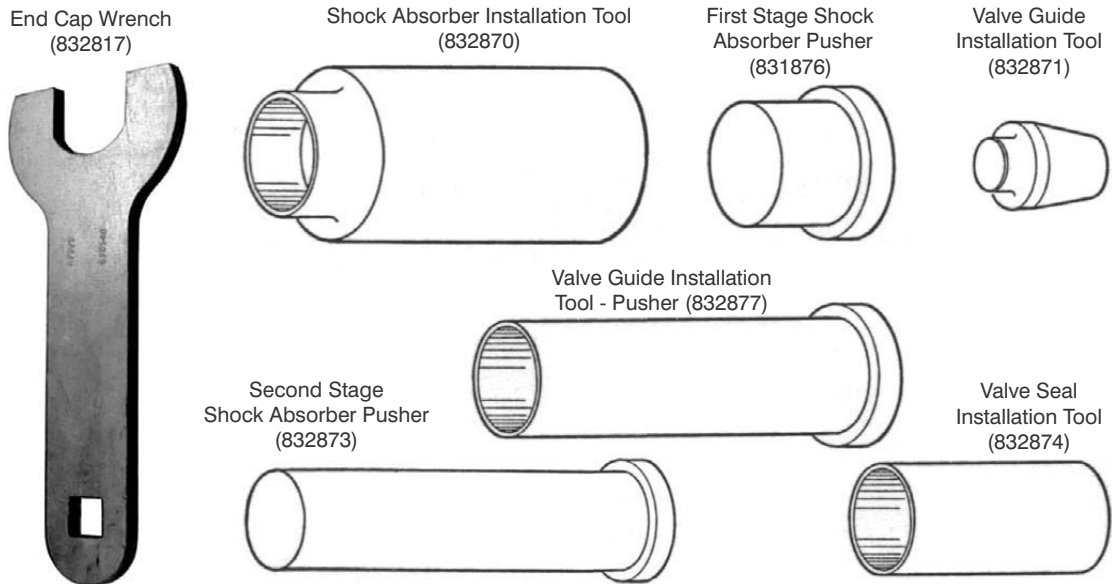

Figure 8-1. Hole-Hog Tool Kit



WARNING

Applying heat with a torch or by any other method to any part or parts of the Hole-Hog relieves Allied of all warranty responsibilities. Applying heat can destroy the main body, striker and other parts beyond use. Heating Hole-Hog components can cause altered component strength and result in premature failure or personal injury.



WARNING

Using a pipe wrench on the Hole-Hog Body/Anvil relieves Allied of all warranty responsibilities

8.3 Extent of Disassembly

The procedures in this section completely disassemble every replaceable component in the Hole-Hog. Most repairs do not require such a complete disassembly. After removing the Tail Assembly and Striker from the Body/Anvil (paragraph 8.6), clean and inspect the internal components while they are still assembled. After cleaning and inspection, perform only the minimum disassembly required to replace worn or broken parts.

8.4 Whip Hose Replacement

- To Replace the Whip Hose (13) in the field, refer to paragraph 11.1.
- To Replace the Whip Hose (13) as part of shop disassembly follow the procedures in this section, starting with 8.7.1.

8.5 Replacing The Body/Anvil and Cap

1. When replacing the Body/Anvil (1) only, it is not necessary to disassemble the Whip Hose (13) and tail assembly components.
 - a. Remove Striker (2), and tail assembly with Whip Hose attached as described in paragraph 8.6.
 - b. Until the new Body/Anvil is installed, place the Striker (2), Whip Hose (13) and tail assembly where they will not be contaminated with dust and dirt. Cover or wrap them in cloth or plastic as required.
2. For Threaded Anvil (TH) Units only.
 - a. When replacing a worn Body/Anvil (1), also replace the Anvil Cap (17).
 - b. To replace only the Anvil Cap, refer to Section 9.4.1, Step 2.

8.6 Removing Tail Assembly and Striker

1. Place the Hole-Hog on a level surface. Holding the body/anvil (1) with a strap wrench, use wrench P/N 832817 from the Tool Kit to loosen the End Cap (9). It may be necessary to strike the wrench handle several times with a hammer to loosen the End Cap. Refer to Figure 8-2.

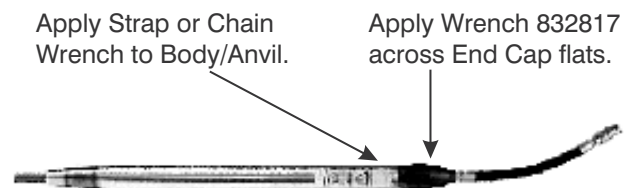

Figure 8-2. Loosening the End Cap

2. Remove the tail assembly by unthreading the End Cap (9) and pulling the tail assembly from the Body/Anvil (1) as shown in Figure 8-3.

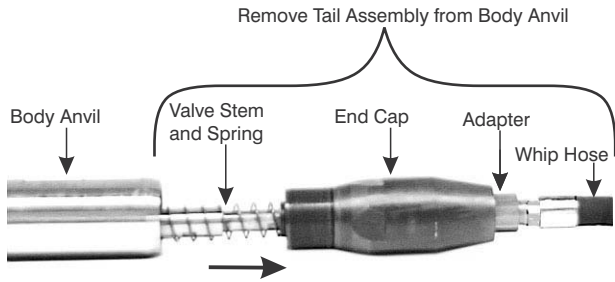



Figure 8-3. Removing the Tail Assembly

3. Place the tail assembly where it will not be contaminated with dust and dirt. Wrap it in cloth or plastic if necessary.



WARNING

The Body/Anvil and Striker are heavy. Bodily injury could result from improper handling of heavy components.

4. Remove the Striker (2) from the Body/Anvil (1):
 - a. If it is unsafe or impractical to lift the Body/Anvil and Striker, use a long hook to pull the Striker out of the Body/Anvil about six to eight inches as shown in Figure 8-4. Otherwise, perform step b.
 - b. Tip the Body/Anvil (1) so the end of the Striker (2) slides out of the Body/Anvil about six to eight inches. (Figure 8-5).

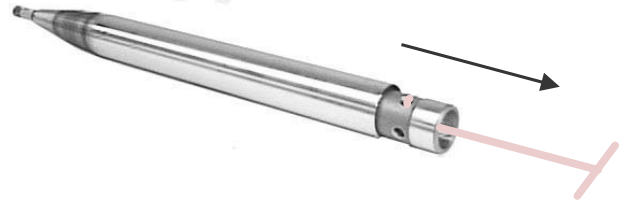

Figure 8-4. Access The Striker With a Long Hook.

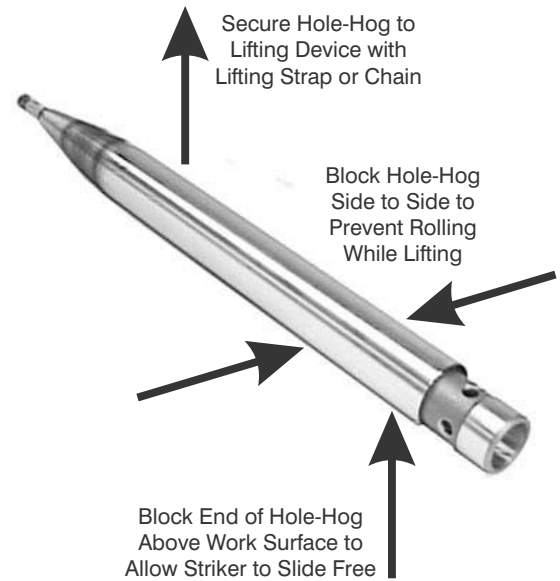

Figure 8-5. Tilting the Body/Anvil to Access the Striker

5. Once the Striker (2) is accessible, lower the Body/Anvil (1) to the level surface and block it to prevent rolling. Pull the striker from the Body/Anvil by hand as shown in Figure 8-6.
6. Place the Striker where it will not be contaminated with dust and dirt. Wrap it in cloth or plastic if necessary.

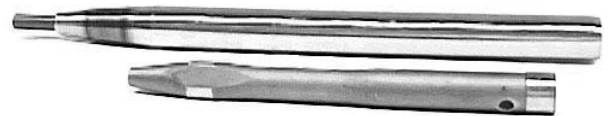

Figure 8-6. Striker Removed from Body/Anvil.

8.7 Disassembling the Tail Assembly

NOTE

DO NOT disassemble components of the tail assembly unless replacement is necessary.

8.7.1 Remove Whip Hose and Fittings

1. Place the Tail Assembly in a vice or saddle clamp. Secure the End Cap (9) tight enough to hold Tail Assembly in place.
2. Using a 1-3/4-inch open-end wrench to hold the Adapter (11) in place, use a 1-3/8-inch open-end wrench to loosen and thread the hose fitting of Whip Hose (13) from the Adapter. Refer to Figure 8-7.

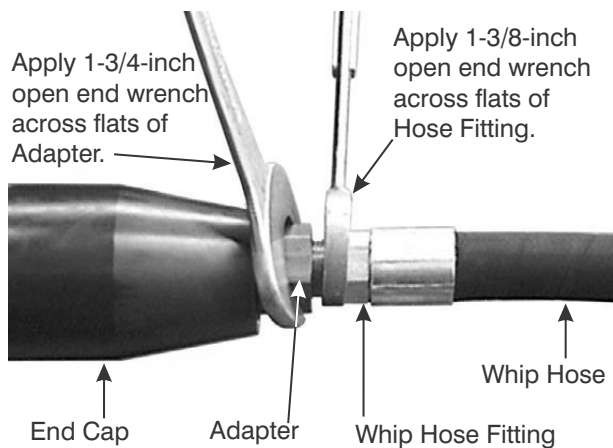

Figure 8-7. Remove Whip Hose.

3. Remove the End Cap and the other Tail Assembly parts from the vice. Place them where they will not be damaged or contaminated with dust and dirt while the Whip Hose is repaired and replaced.
4. Using a 2-inch open-end wrench to hold the Quick Disconnect Socket (14) in place, use a 1-3/8-inch open-end wrench to loosen and thread the hose fitting of Whip Hose (13) from the Socket. Refer to Figure 8-8.



Figure 8-8. Remove Coupling Socket from Whip Hose.

5. If parts replacement is not required, leave the Quick Disconnect (Q.D.) Couplings assembled. Otherwise, separate the Socket (14) from the Plug (16).
6. As shown in Figure 8-9, use a screw driver or needlenose pliers to pry the Gasket (15) from the Socket. Discard the gasket.



Figure 8-9. Remove Gasket from Coupling Socket.

8.7.2 Remove Valve from End Cap

CAUTION
The Valve Stem is under spring pressure.

1. Place the End Cap (9) in a vice or saddle clamp so the Cone Point Set Screw (12) is accessible. Secure the End Cap (9) tight enough to hold it in place while working. See Figure 8-10.

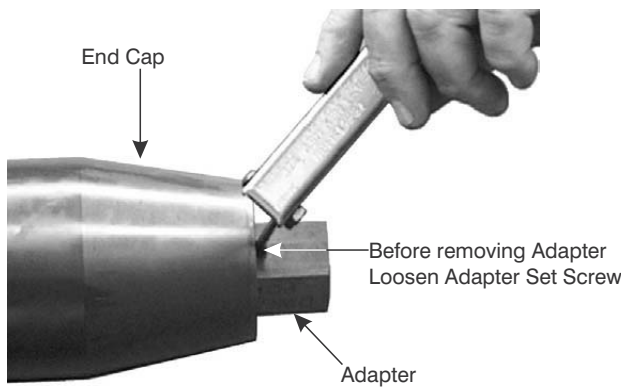

Figure 8-10. End Cap In Vice with Set Screw Accessible

2. Remove the Cone Point Set Screw (12) as shown in Figure 8-10.
3. Use a 1-3/4-inch open-end wrench to hold the Adapter (11) in place, as shown in Figure 8-11.

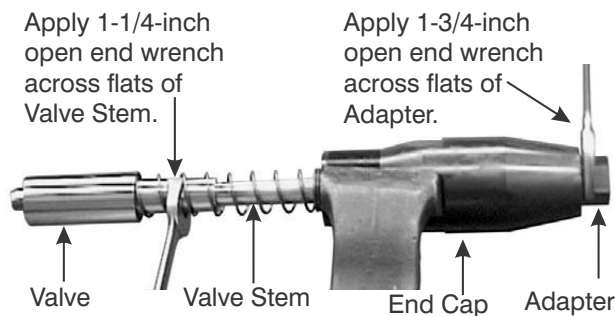

Figure 8-11. Thread Valve Stem from Adapter.

4. With a 1-1/4-inch open-end wrench across the flats of the Valve Stem (5), thread the Valve Stem (5) from the Adapter (11) as shown in Figure 8-11.
5. Holding Spring (6) and Valve (3) in one hand, pull the Valve Stem (5) and its assembled components out of the Valve Guide (7). See Figure 8-12-A.

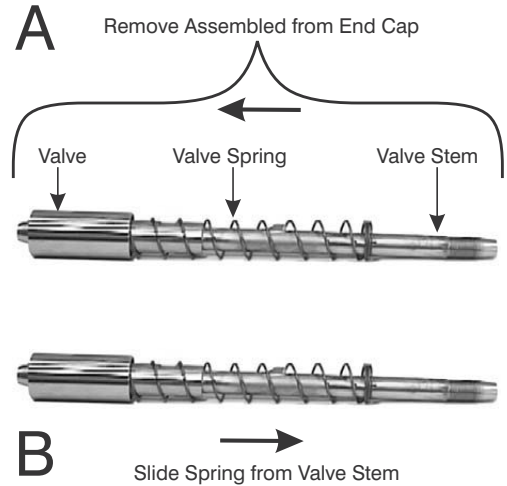

Figure 8-12. Valve Stem Components Removed from End Cap.

6. Slide the Spring (6) from the Valve Stem (5). See Figure 8-12-B.

8.7.3 Remove Valve and Bushing

NOTE

DO NOT disassemble the Valve, Valve Bushing and Valve Stem unless replacement of one or more is necessary.

1. Refer to Figure 8-13-A, and position the Valve Stem (5) and its assembled components in an arbor press.

- Support the edges of the Valve (3) with standard blocking. Allow the Valve Stem to hang freely below the blocking.
- Place the plunger of the arbor press against the tip of the Valve Stem (5) protruding above the Valve.

2. Press the Valve Stem (5) and Bushing (4) from the Valve (3) as shown in Figure 8-13-B.

3. When unseated from the Bushing, the Valve can be pulled from the assembled Valve Stem and Bushing by hand, as shown in Figure 8-14.

4. Pull Valve Bushing (4) from the Valve Stem (5) by hand. See Figure 8-15.

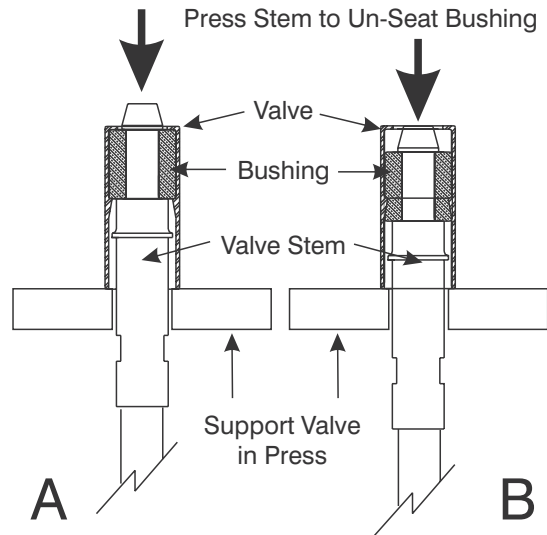

Figure 8-13. Valve Stem and Components in Arbor Press.

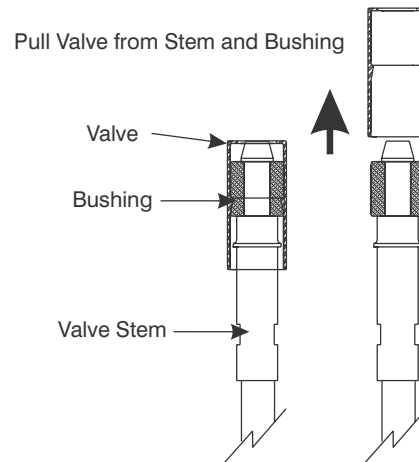

Figure 8-14. Remove the Valve from the Assembled Valve Stem and Bushing.

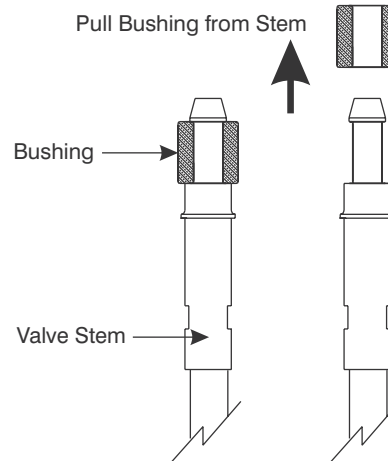



Figure 8-15. Remove the Valve Bushing from the Valve Stem.

8.7.4 Disassemble End Cap Components



CAUTION

Removal destroys Shock Absorber. DO NOT remove Shock Absorber (8) and Valve Guide (7) from End Cap (9) unless replacement is necessary.

1. Use a sharp knife or hack saw to cut through the Valve Seal (10). Using a large screw driver or needlenose pliers, pry the Valve Seal from the End Cap. Discard the Seal. See Figure 8-16.

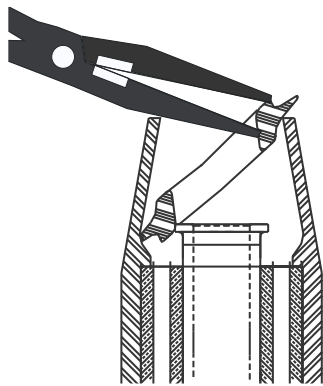

Figure 8-16. Removing The Valve Seal from The End Cap

2. With its threaded end down, place the End Cap in the arbor press.
 - Support the edges of the End Cap (16) with standard blocking.
 - Provide additional space below the blocking to permit Valve Guide travel during pressing.
3. Insert the Valve Guide Installation Tool 832871 in the Valve Guide (7) as shown in Figure 8-17.

NOTE.

If the plunger of the arbor press does not fit inside the End Cap as illustrated, any piece of common bar stock that fits can be used as a pusher.

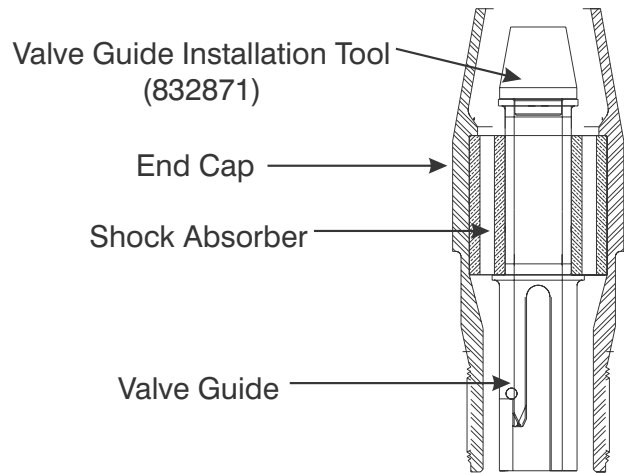

Figure 8-17. Insert Valve Guide Tool.

4. Press the Valve Guide from the Shock Absorber as illustrated in Figure 8-18. Once started from the Shock Absorber, the Valve Guide can be pulled free by hand.

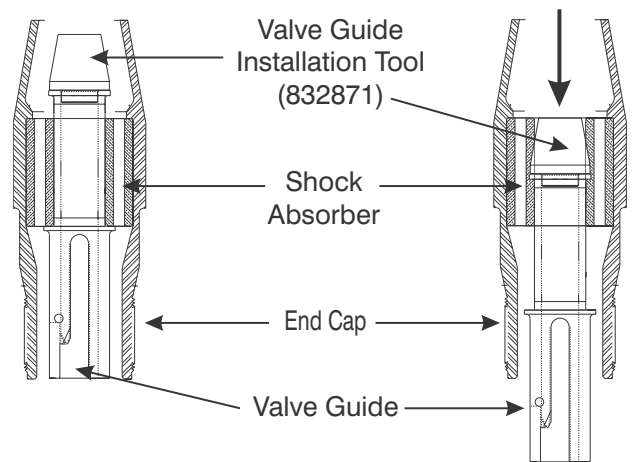

Figure 8-18. Press Out Valve Guide.

5. Use a sharp knife or hack saw to cut through the Shock Absorber (8), and remove it from the End Cap (9). See Figure 8-19.

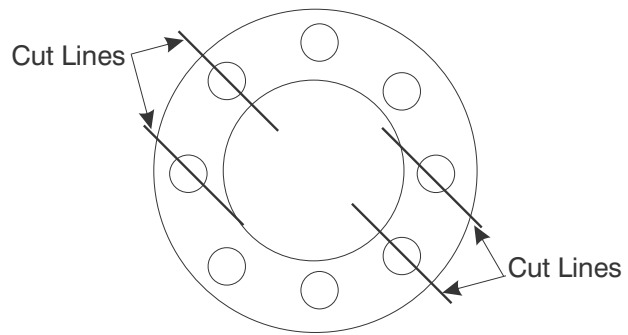

Figure 8-19. Cutting Pattern for Shock Absorber.

SECTION 9.0 ASSEMBLY**WARNING****G**

Applying heat with a torch or by any other method to any part of the Hole-Hog relieves Allied of all warranty responsibilities. Applying heat can destroy the main body, striker and other parts beyond use. Heating Hole-Hog components can cause altered component strength and result in premature failure, such as ruptures or a blown out end cap. This could cause personal injury or death.

**CAUTION**

Using a pipe wrench on the Hole-Hog Body/Anvil relieves Allied of all warranty responsibilities.

**CAUTION**

Lubricate all rubber parts & tools with lithium grease before pressing. The grease will protect the rubber parts and make installation easier.

**CAUTION**

Before starting any of the Assembly procedures in this section, refer to Section 3.1 and verify the Serial Number of the unit to be assembled. Refer to sections 9.2 and 9.3 for information about the differences among serial number groups.

9.1 General

The procedures in this section must be performed in a machine shop suitable for the cleaning, inspection, repair and assembly of pneumatic construction equipment. In addition to the tools and fixtures normally stocked in such a shop, the Allied Tool Kit 832872 must also be available.

In the following procedures, reference numbers in parentheses accompany most part names. These numbers refer to the part item numbers on the exploded views and parts lists in Section 14.0.

**9.2 Disassembly and Assembly Tool Kit
Part Number 832872**

The Allied Disassembly and Assembly Tool Kit, P/N 832872, is described and illustrated in Disassembly Section 8.1.

9.3 Whip Hose Replacement

- To Replace the Whip Hose (13) in the field, refer to paragraph 11.1
- To Replace the Whip Hose (13) as part of shop assembly, follow the procedures in this section, starting with Section 9.6.

9.4 Replacing The Body/Anvil Only

When replacing the Body/Anvil (1) only, the Striker (2) and tail assembly components are removed from the Body/Anvil and stored with no further disassembly as described in Section 8.5.

1. When the new Body/Anvil is available, bring the Striker (2), and tail assembly components to the work area for reassembly.
2. Install all of the assemblies in the Body/Anvil following the assembly procedures in this section, starting with Section 9.8.

9.4.1 Threaded Anvil (TH) Units Only

1. A replacement Body/Anvil (1) includes a new Anvil Cap (17). Check that it is securely attached to the Body/Anvil as described below.
2. If the Anvil Cap alone is being replaced, install it hand tight on the Anvil/Body. Then, with the Body/Anvil held securely by a strap wrench, use an 1-3/4-inch open end wrench to tighten the Anvil Cap another 1/8-inch.

9.5 Assemble End Cap Components

1. Position the End Cap (9) in an arbor press with the threaded end up. Insert the Shock Absorber Installation Tool 832870 into the threaded end of the End Cap as shown in Figure 9-1-A.
2. Lubricate the O.D. of the Shock Absorber (8) and the I.D. of the Shock Absorber Installation Tool, 832870 . Place the Shock Absorber into the Installation Tool as shown in Figure 9-1-B.

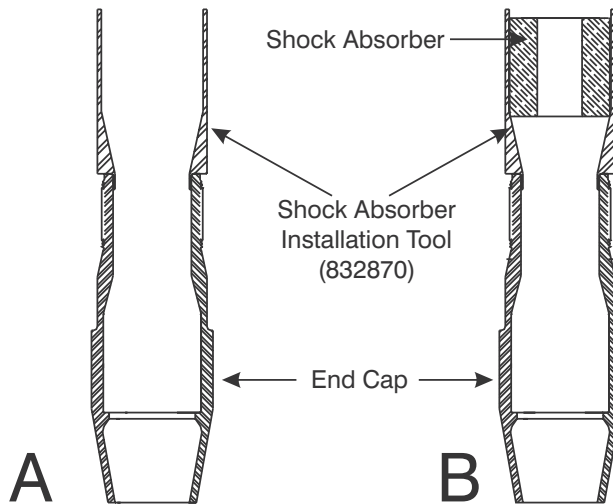

Figure 9-1. End Cap, Tool 832870 and Shock Absorber

3. Center the First Stage Shock Absorber Pusher Tool 832876 over the Shock Absorber as shown in Figure 9-2 -A.
4. Press the Shock Absorber into the End Cap as shown in Figure 9-2-B.
5. Stop pressing when the cap of the Pusher Tool touches the sides of the Installation Tool, as shown in Figure 9-2B and 9-3.

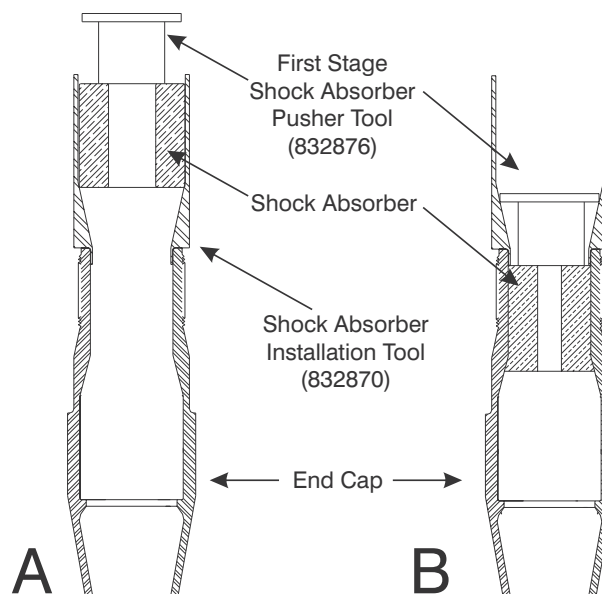

Figure 9-2. Press the Shock Absorber into the End Cap.

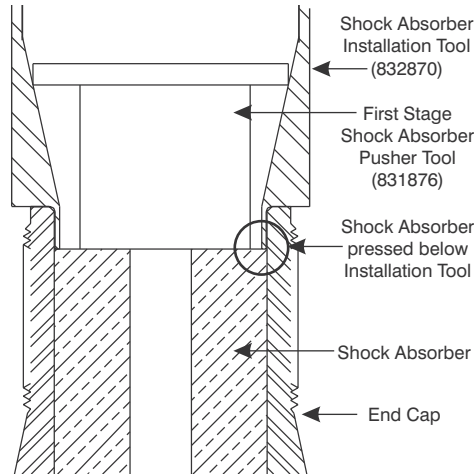



Figure 9-3. Shock Absorber in End Cap

6. When the pusher tool reaches this depth, the Shock Absorber has cleared the end of the Installation Tool, as shown in Figure 9-3.



CAUTION

Do Not remove the Installation Tool 832870 unless the Shock Absorber has cleared the bottom of the tool as shown in Figure 9-3(B).

7. After pressing the Shock Absorber through the Installation Tool and into the End Cap, remove the Installation Tool from the End Cap.
8. Center the Second Stage Shock Absorber Pusher 832873 over the Shock Absorber as shown in Figure 9-4-A.
9. Press the Shock Absorber into the End Cap until it seats against the shoulder at the non-threaded end of the cap as shown in Figure 9-4-B.
10. Lubricate the I.D. of the Shock Absorber (8) and the I.D. of the Valve Guide Installation Tool 832877. Lubricate the exterior of the Valve Guide Installation Tool 832871 and the Valve Guide (7) . Refer to Figure 9-5-A.

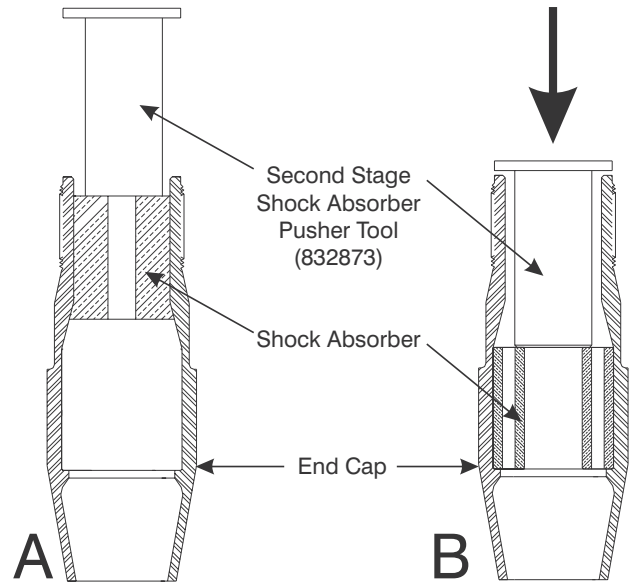

Figure 9-4. Seat the Shock Absorber in the End Cap.

11. Center the Valve Guide Installation Tool 832871 and the Valve Guide (7) over the bore of the shock absorber as shown in Figure 9-5-B.

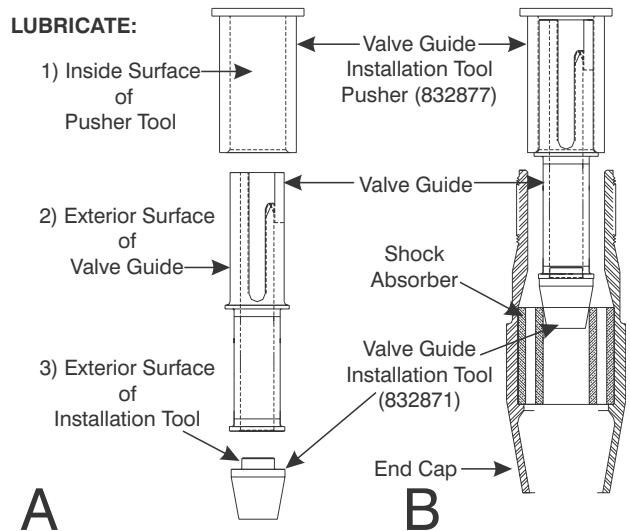

Figure 9-5. Prepare Valve Guide for Installation into the Shock Absorber.

12. Slide the Valve Guide Installation Tool - Pusher (832877) over the upper end of the Valve Guide as shown in Figure 9-5-B.
13. Press the Valve Guide into Shock Absorber until the center shoulder of the Valve Guide seats against the Shock Absorber as shown in Figure 9-6-B.

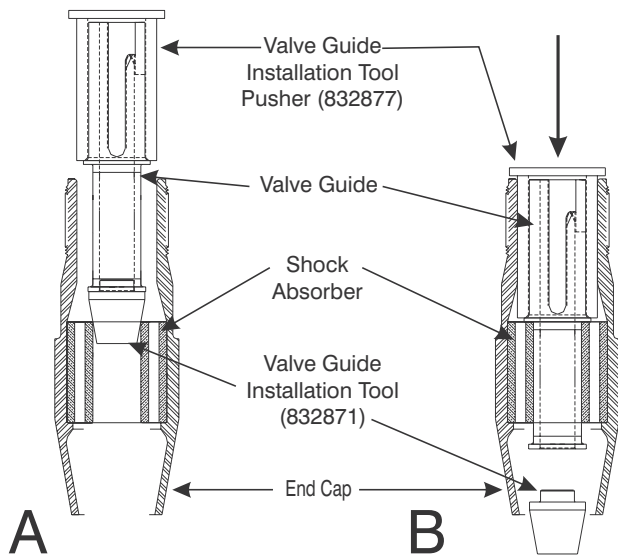

Figure 9-6. Press the Valve Guide into The Shock Absorber.

14. The Valve Guide Installation Tool 832871 will fall free of the Valve Guide when the Valve Guide seats against the Shock Absorber.
15. Remove the End Cap from the arbor press and remove the Valve Guide Installation Tool Pusher 832877.
16. Look inside the non-threaded end of the End Cap and lubricate that part of the Valve Guide that protrudes from the Shock Absorber. See Figure 9-7-A.
17. Turn the End Cap over and place it in the arbor press with the threaded end down.

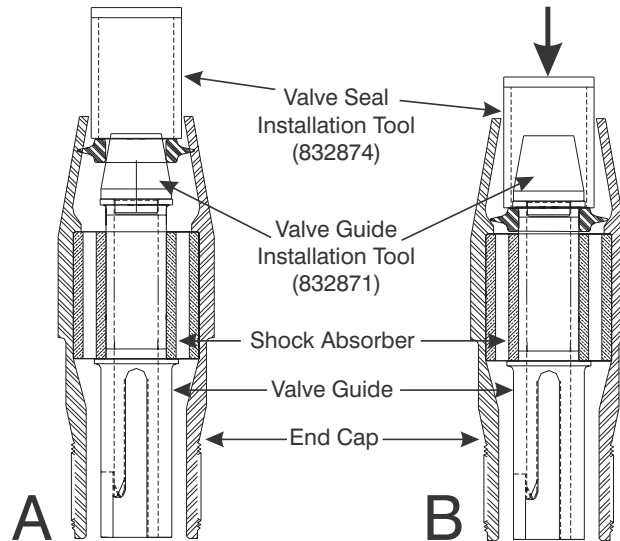



Figure 9-7. Press Valve Seal into End Cap and onto Valve Guide.

18. Lubricate the Valve Guide Installation Tool 832871 and Valve Seal (10).
19. Place the Valve Guide Installation Tool 832871 into the Valve Guide. The smaller part of the cone faces up as shown in Figure 9-7-A.
20. Place the Valve Seal (10) around the cone of the Valve Guide Installation tool as shown in Figure 9-7-A.
21. Center the Valve Seal Installation Tool 832874 in the End Cap opening and above the Valve Seal and Valve Guide Installation Tool. See Figure 9-7-A.
22. With the Valve Seal Installation Tool 832874, press the Valve Seal into the End Cap until the seal seats between the Shock Absorber and the shoulder at end of the Valve Guide as shown in Figure 9-7-B.

9.6 Assemble Whip Hose Components



WARNING

Always use Allied's Whip Hose Assembly (see parts lists in Section 13.0) or equivalent: 100R2 hose. Failure to use 100R2 hose could result in injury to personnel.

1. With the grooved face of the Gasket (15) toward the Quick Disconnect (Q.D.) Socket (14) and Whip Hose (13), insert the new Gasket (15) into the Socket (14). Check that the gasket seats properly. Refer to Figure 9-8.

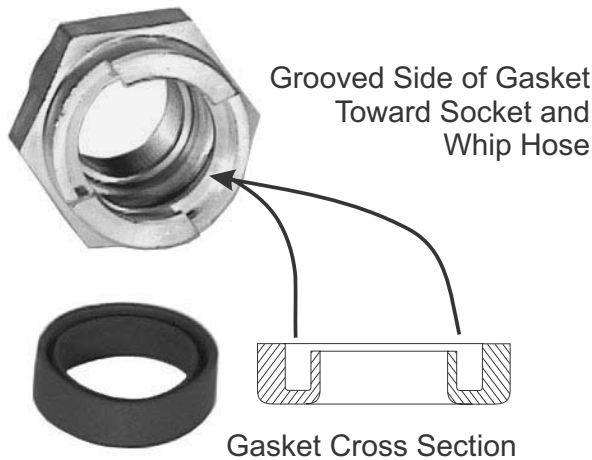

Figure 9-8. Insert New Gasket in Q.D. Socket.

2. Place the assembled Q.D. fitting and the Whip Hose on the assembly bench.
3. At one end of the Whip Hose, wrap the external threads of the hose fitting with teflon tape as shown in Figure 9-9.
4. Use a 2-inch open-end wrench to hold the Q.D. Socket in place, and a 1-3/8-inch open-end wrench to tighten the fitting of Whip Hose into the Q.D. Socket. See Figure 9-10.

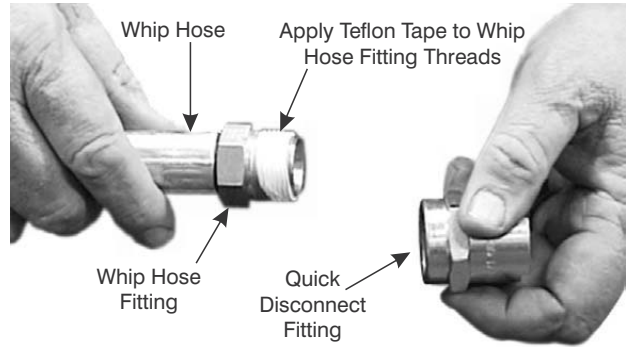

Figure 9-9. Apply Teflon Tape to Hose Fitting.



Figure 9-10. Secure Whip Hose to Q.D. Socket.

9.7 Assemble Tail Assembly Components

NOTE

Except for the End Cap, lubricate all tail assembly components prior to assembly.

9.7.1 Valve, Bushing and Valve Stem



CAUTION

When clamping the Valve Stem in a vise or saddle clamp, pad the jaws to prevent damage to the finish surface.

1. Place the Valve (3), Valve Bushing (4) and Valve Stem (5) on the work bench. Secure the Valve (3) in a padded vice or saddle clamp tight enough to prevent movement during assembly.
2. Lubricate the inside of the Bushing. Lubricate the non-threaded end of the Valve Stem from the tip to the bushing seat as shown in Figure 9-11.

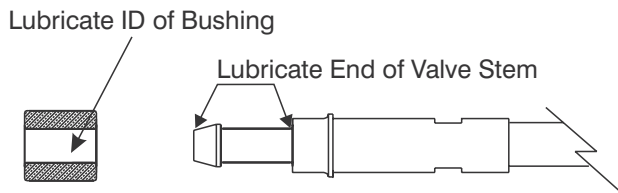

Figure 9-11. Lubricate End of Valve Stem.

3. By hand, press the Bushing over the knob at the non-threaded end of the Valve Stem. Slide the Bushing into place between the knob and bushing seat as shown in Figure 9-12.

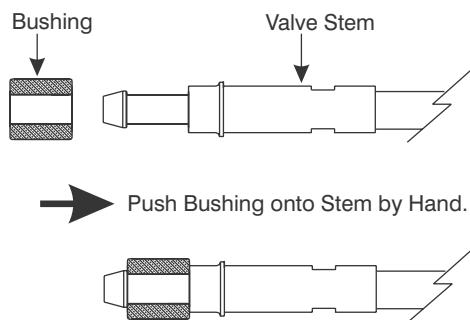

Figure 9-12. Install Bushing on Valve Stem.

4. Lubricate the outside of the Valve Bushing (4) and the inside of the Valve.
5. With the larger bore toward the Valve Stem, slide the Valve over the Bushing as shown in Figure 9-13.
6. With the threaded end down, place the Valve Stem in an arbor press. Hold it in

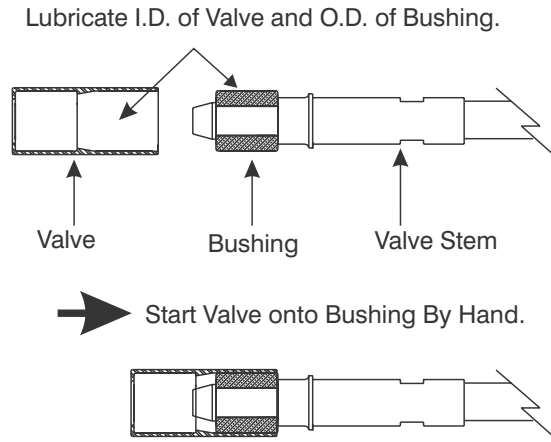

Figure 9-13. Install Valve on Bushing.

place by hand. Place the Valve Seal Installation Tool 832874 on top of the Valve as shown in Figure 9-14.

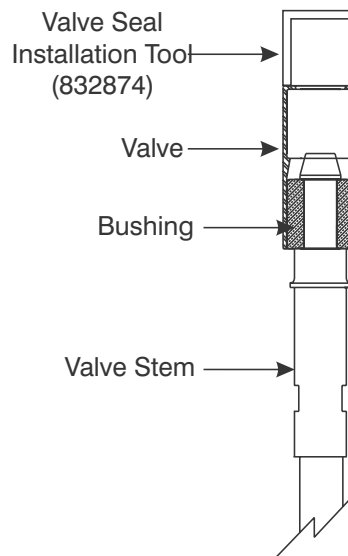

Figure 9-14. Valve Pressing Tool on Valve

7. Refer to Figure 9-15. and press the Valve onto the assembled Bushing and Stem:
 - Seat the Valve against the top of bushing.
 - Seat the bottom of the bushing against the interior shoulder of the Valve.

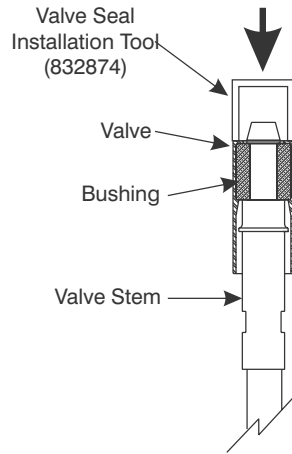

Figure 9-15. Press Valve onto Bushing and Valve Stem.

9.7.2 Valve Stem, Spring, and End Cap

1. To prevent it from moving during assembly, fasten the End Cap (9) securely in a vise or saddle clamp.
2. Slide the Spring (6) onto the tapered and threaded end of the Valve Stem (5) as shown in Figure 9-16.

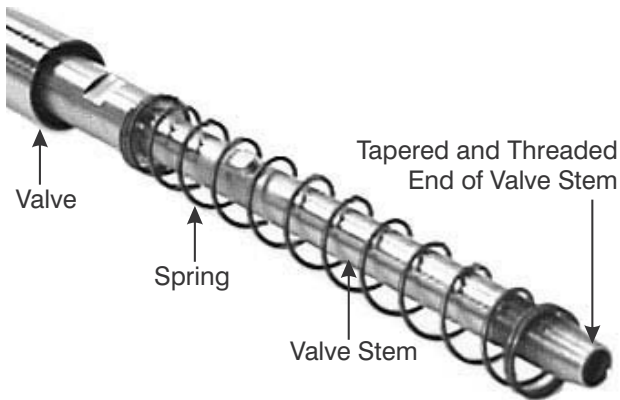

Figure 9-16. Slide Spring onto Valve Stem.

3. Refer to Figure 9-17, and guide the Spring (6) and Valve Stem (5) into the threaded end of the End Cap (9), and then into the Valve Guide (7).
4. Continue to slide Valve Stem (5) into Valve Guide (7) until the Valve Stem

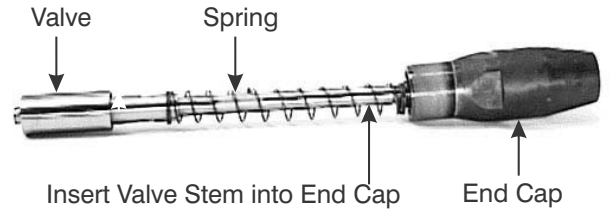

Figure 9-17. Slide Valve Stem and Spring into End Cap and Valve Guide.

threads protrude from the other side of the End Cap (9). See Figure 9-18.

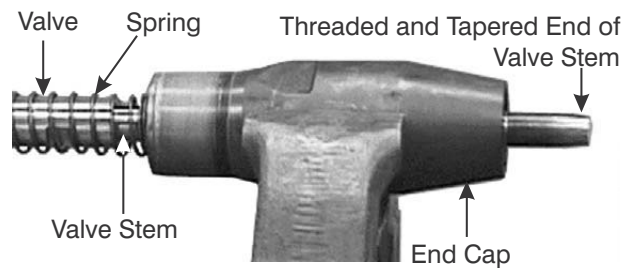

Figure 9-18. Valve Stem Threads

5. Thread the Adapter onto the Valve Stem (5) and hand tighten. See Figure 9-19

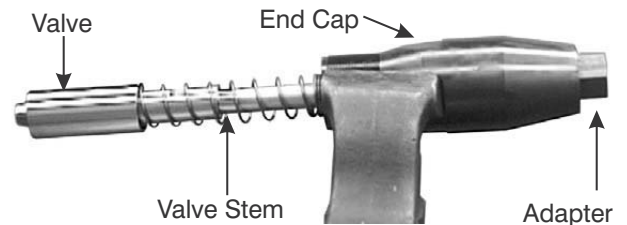

Figure 9-19. Valve Stem and Adapter

6. Use a 1-3/4-inch open-end wrench to hold the Adapter (11) in place, as shown in Figure 9-20.
7. With a 1-1/4-inch open-end wrench across the flats of the Valve Stem (5), thread the Valve Stem into the Adapter (11) until it is wrench tight. Refer to Figure 9-20.

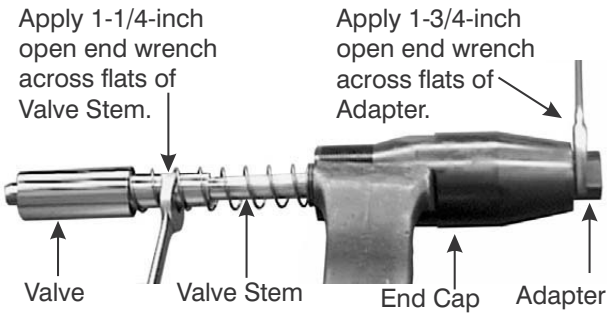

Figure 9-20. Secure Valve Stem to Adapter

8. Insert the Cone Point Set Screw (12) and tighten to prevent the Adapter from backing off of the Valve Stem. See Figure 9-21.

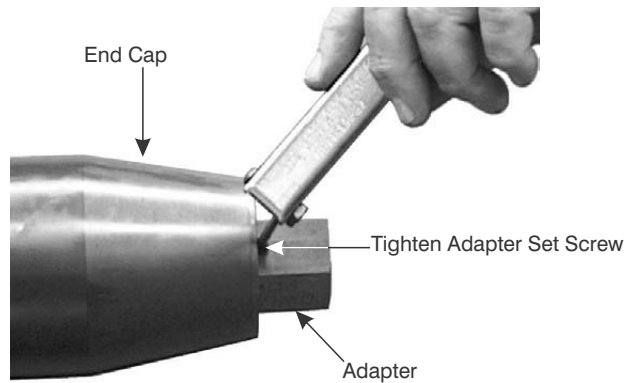

Figure 9-21. Tighten Set Screw.

9. Apply teflon tape to the external threads of the hose fitting at one end of the Whip Hose. See Figure 9-22.

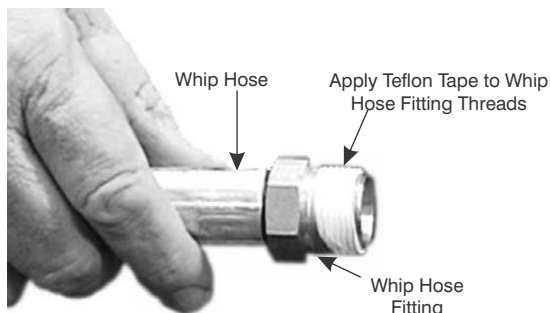

Figure 9-22. Apply Teflon Tape to Hose Fitting.

10. Start the teflon covered fitting into the Adapter.

11. Use a 1-3/4-inch open-end wrench to hold the Adapter (11) in place, and a 1-3/8-inch open-end wrench to secure the Whip Hose (13) fitting in the Adapter (11) . See Figure 9-23.

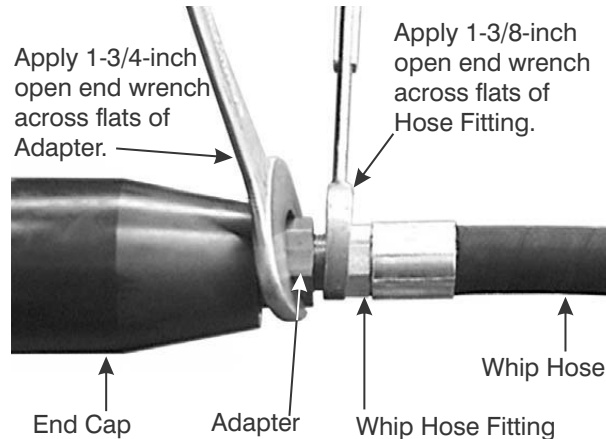

Figure 9-23. Secure Whip Hose To Adapter.

9.8 Body/Anvil, Striker and Tail Assembly

NOTE

The Body/Anvil and Striker are not customer serviceable. If these components are worn or damaged, replace them with new components.



WARNING

The Body/Anvil and Striker are heavy. Bodily injury could result from improper handling of heavy components.

1. Coat the Striker (2) with hydraulic fluid before installing it into Body/Anvil (1).
2. Refer to Figure 9-24 and slide the Striker (2) into the Body/Anvil (1). The back end of the Striker should be about 6 to 8 inches in (past the threads of the Body/Anvil).

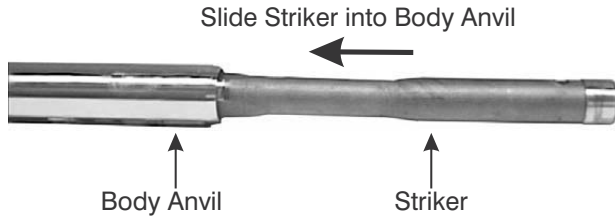

Figure 9-24. Slide Striker into Body/Anvil

3. Apply anti-seize thread lubricant sparingly to the threads of the End Cap (9) and the Body/Anvil (1). See Figure 9-25.

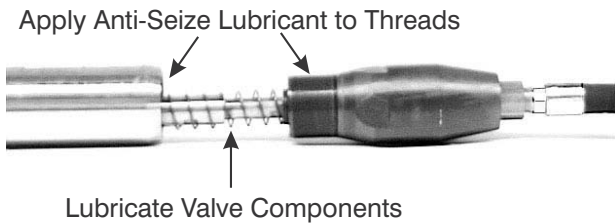

Figure 9-25. Prepare Tail Assembly and Body/Anvil for Assembly

4. Coat the valve assembly components with hydraulic fluid, as shown in Figure 9-25.
5. Insert the Valve (3) into the end bore of the Striker (2) and thread the End Cap (9) into the Body/Anvil (1). Refer to Figure 9-26.

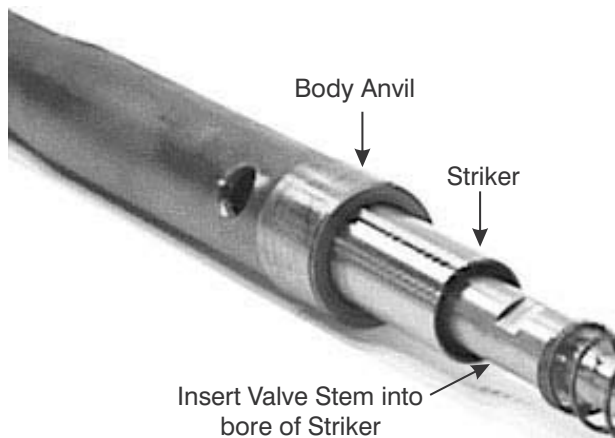

Figure 9-26. Insert Valve into Striker.

6. Hand tighten the End Cap (9) to the Body/Anvil (1).
7. Place the Hole-Hog on a level surface. Holding the Body/Anvil (1) with a strap wrench, use wrench P/N 832817 from the Tool Kit to tighten the End Cap (9), as shown in Figure 9-27.

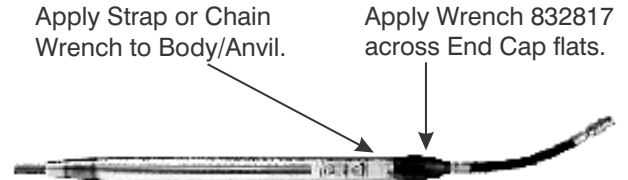

Figure 9-27. Fasten End Cap to Body/Anvil

8. Tighten the End Cap to a torque of 750-1000 ft.-lbs (1015-1355 n-m). If a torque wrench is not available, use the following procedure. See Figure 9-28.

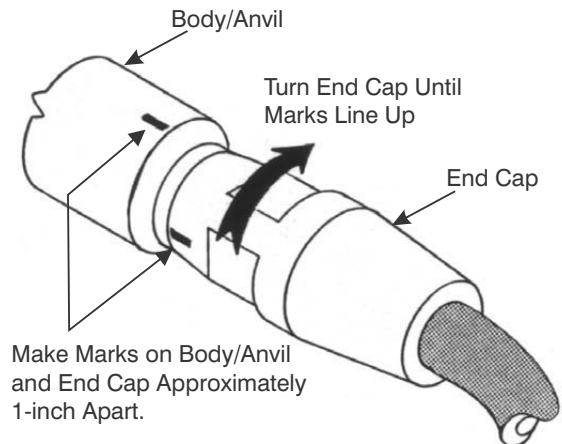

Figure 9-28. Tighten the End Cap to the Required Torque

- a. After tightening the End Cap hand tight, put a scribe mark on the Body/Anvil next to the End Cap.
- b. On the End Cap, place a second scribe mark 3-3/16-inch counter clock wise to the first mark.

- c. Using P/N 832817 wrench, tighten the End Cap until the two scribe marks align.

9.9 Installing the Anvil Cap

For Threaded Anvil (TH) Units Only

1. Place the Hole-Hog on a level surface and thread the Anvil Cap (17) onto the Body/Anvil (1) hand tight.
2. Hold the Body/Anvil (1) in place with a strap or chain wrench as shown in Figure 9-30.
3. With a 1-3/4-inch wrench, tighten the anvil cap a minimum 1/8-inch past hand tight. Refer to Figure 9-30

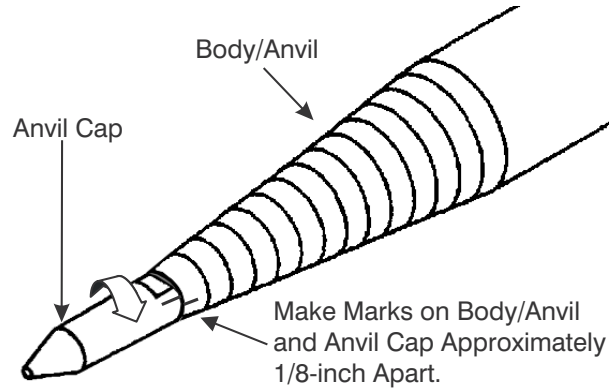

Turn Anvil Cap
Until Marks Line Up

Figure 9-30. Tighten the Anvil Cap to the Required Torque

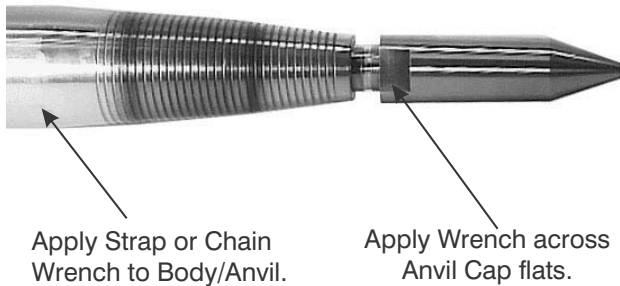

Figure 9-29. Secure Anvil Cap to Body/Anvil

SECTION 10.0 MAINTENANCE

10.1 Daily Maintenance

- Clean and lubricate end cap threads with an anti-seize lubricant. Tighten end cap according to procedure in Section 9.8, Step 8.
- Clean and oil Hole-Hog.
- Lubricate Hole-Hog according to Section 7.0.
- **TH Models:** Check anvil cap. If anvil cap is loose, remove cap and clean and lubricate threads with an anti-seize lubricant. Install cap hand tight on the anvil, then tighten another minimum 1-8-inch (refer to Section 9.9).

10.2 Inspection And Preventive Maintenance

After every 100 hours of operation, the Hole-Hog should be disassembled, cleaned and inspected.

- Check all components for abrasion and excessive wear. Repair or replace as required.
- Inspect the body and anvil for cracks or large chips. Replace if excessively worn. A smoothly worn body is acceptable.
- Check the exhaust ports in the shock absorber for obstructions. Clean and check for damage.
- Check hose for excessive wear or kinks. Replace a damaged hose.

- Check shock/valve guide for proper seating. Press into place or replace shock if necessary.

10.3 Conditional Maintenance

Disassemble, clean and lubricate all Hole-Hog working surfaces under the following conditions:

- The Hole-Hog is to be stored for more than one week.
- The Hole-Hog is operated in extremely humid weather conditions.
- The Hole-Hog is operated in muddy or extremely wet soils.
- If reduced performance is observed.

10.4 Warranty Protection

Maintain written records of Hole-Hog maintenance, service and repair. These records will be helpful if warranty coverage is ever in question. Each record shall include :

- The date of service, maintenance or repair.
- A description of the service, maintenance or repair performed. Include part numbers if applicable.
- Copies of purchase order(s) and invoice(s) for repair parts and service.

The name and signature of the person performing the service, maintenance or repair.

SECTION 11.0 FIELD MAINTENANCE

11.1 Field Replacement of the Whip Hose



WARNING
 Always use Allied's Whip Hose Assembly (see parts lists in Section 13.0) or equivalent - 100R2 hose. Failure to use 100R2 hose could result in injury to personnel.

The Whip Hose (13) may be changed as part of shop disassembly, Section 8.0, or changed in the field by the following procedure.

11.1.1 Remove Old Whip Hose

1. Place the Hole-Hog on a clean, level surface. If necessary, hold it in place with a strap wrench.
2. Using a 1-3/4-inch open-end wrench to hold the Adapter (11) in place, use a 1-3/8-inch open-end wrench to loosen and thread the hose fitting of Whip Hose (13) from the Adapter. Refer to Figure 11-1.

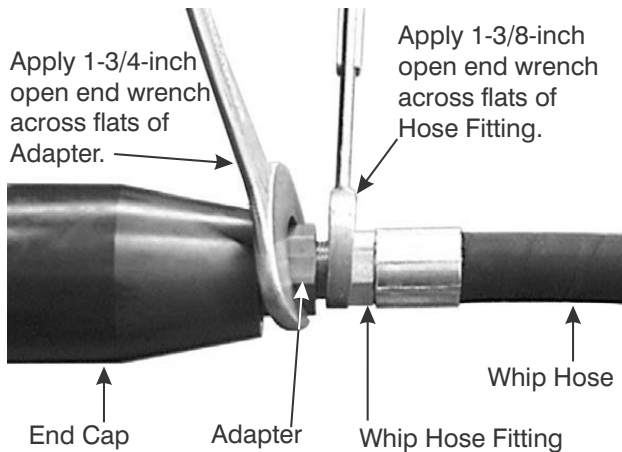

Figure 11-1. Remove Whip Hose from Adapter.

3. Using a 2-inch open-end wrench to hold the Quick Disconnect (Q.D.) Socket (14) in place, use a 1-3/8-inch open-end wrench to loosen and thread the hose fitting of Whip Hose (13) from the Q.D. Socket. Refer to Figure 11-2.



Figure 11-2. Remove Whip Hose from Q.D. Socket

4. Separate the Q.D. Socket and Plug. Inspect the Q.D. Gasket for damage or wear.
5. Remove the gasket only if it is worn or damaged. To remove it, use a screw driver or needlenose pliers to pry the Gasket (15) from the Socket. Discard the gasket. See Figure 11-3.



Figure 11-3. Remove Q.D. Gasket

11.1.2 Install New Whip Hose Assembly

1. Place the new Allied Whip Hose and the Quick Disconnect (Q.D.) fittings on a clean, level assembly surface.
2. If the old Q.D. Gasket (15) was removed, insert a new one in the Q.D. Socket (14).
 - a. With the grooved face of the Gasket (15) toward the Q.D. Socket (14) and Whip Hose (13), insert the new Gasket (15) into the Socket (14). Refer to Figure 11-4.
 - b. Check that the gasket seats properly.

4. Use a 2-inch open-end wrench to hold the Q.D. Socket in place, and a 1-3/8-inch open-end wrench to tighten the Whip Hose fitting into the Q.D. Socket. Refer to Figure 11-2.
5. Place the Hole-Hog on a clean, level assembly surface. If necessary, hold it in place with a strap wrench.
6. Use a 1-3/4-inch open-end wrench to hold the Adapter (11) in place, and a 1-3/8-inch open-end wrench to secure the Whip Hose (13) fitting in the Adapter (11). Refer to Figure 11-1.

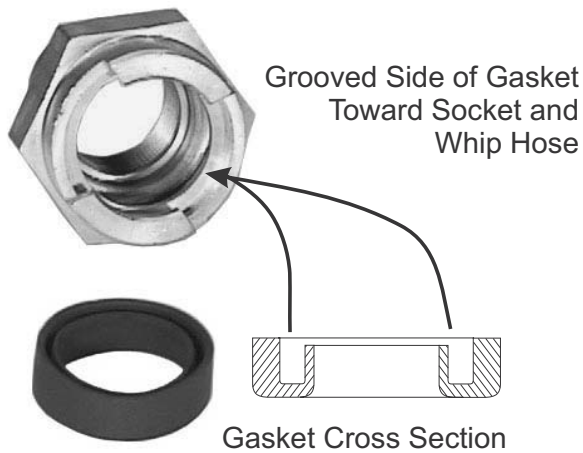

Figure 11-4. Insert Q.D. Gasket into Q.D. Socket.

3. At both ends of the Whip Hose, wrap the threads of the hose fittings with teflon tape as shown in Figure 11-5.

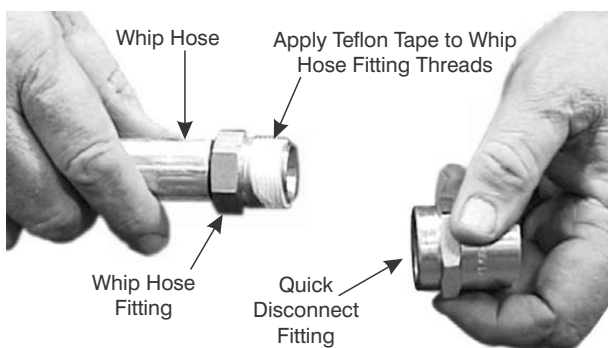

Figure 11-5. Apply Teflon Tape to Hose Fitting.

11.2 Hole-Hog Accessories

Following is a list of Hole-Hog accessories with a brief description and part numbers.

Nose Covers

A nose cover is used to protect the front end wear surface of the body. Nose covers are easily replaceable.

- P/N 832106 - Smooth Nose Cover (2100)
- P/N 832107 - Stepped Nose Cover (2100)
- P/N 832526 - Smooth Nose Cover (2501)
- P/N 832524 - Stepped Nose Cover (2501)

Expanders

Expanders are installed over the front end of the body with the anvil cap. They are used to increase the hole diameter.

- P/N 832040-5-inch Nose Expander (2100)
- P/N 832103 - 6-inch Nose Expander (2100)
- P/N 832136 - 4-3/4-inch Reversible Expander (2100)
- P/N 832142 - 5-3/4-inch Reversible Expander(2100 and 2501)

Pullers

The Pipe Pullers are attached in place of the end cap at the hose end of the Hole-Hog.

PVC pipe is slid over the supply and whip hoses into the PVC Pipe Puller and tightened with four screws.

P/N 832035 - 3-inch PVC Pipe Puller

P/N 832043 - 4-inch PVC Pipe Puller

Puller - Anvil Cap (TH Models)

To install cable with the Pulling Anvil Cap, first the hole is made using the standard anvil cap. The standard anvil cap is then replaced with the Pulling Anvil Cap with cable attached. The Tool is reversed to pull cable back through hole.

P/N 832199 - Pulling Anvil Cap

Pulling Grips

Available in 7 sizes:

P/N 831038 - 3/4-inch to 1-inch

P/N 831045 - 1-inch to 1-1/4-inch

P/N 831051 - 1-1/4-inch to 1-1/2-inch

P/N 831052 - 1-1/2-inch to 1-3/4-inch

P/N 831053 - 1-3/4inch to 2-inch

P/N 831054 - 2-inch to 2-1/2-inch

P/N 831059 - 2-1/2-inch to 3-inch

Pipe Pushing Adapter

The pipe pushing adapter is threaded onto the pipe on one end and secured over the anvil on the other end. The pipe is pushed through the ground by the Hole-Hog.

P/N 832033 Pipe Pushing Adapter
(all models)

Air Line Lubricator

The Air Line Lubricator is used to provide continuous lubrication to the Hole-Hog. Refer to Parts Diagram, Section 13.0
P/N 832024 - Air Line Lubricator

11.3 Installing Nose Covers and Expanders**11.3.1 Models without Anvil Cap**

To install either the nose covers or expanders, slide the accessory over the front end of the Hole-Hog.

11.3.2 Models with Anvil Cap

1. Secure the Hole-Hog with a strap or chain wrench.
2. Using a 1-3/4-inch open end wrench, remove the standard anvil cap.
3. To install either the nose covers or expanders, slide the accessory over the front end of the Hole-Hog and secure in place with the standard anvil cap.
4. The pulling anvil cap is installed in place of the standard anvil cap.

SECTION 12.0 HOLE-HOG TROUBLESHOOTING CHART

The following chart outlines corrective actions for several commonly encountered conditions. For further information, contact the Allied Technical Service Department.

Hole-Hog Troubleshooting Chart

Will not run or start	Runs erratically in forward	Runs erratically in reverse	Stops in ground	Low impact power	Slow ground penetration	Cause & Corrective Action
X	X	X	X	X		Restriction in air supply hose. Disconnect & purge hose.
X	X	X				Bent valve stem. Replace valve stem.
	X	X			X	Air pressure too high. Check air pressure.
X				X		Air pressure too low. Check air pressure.
X	X	X	X	X		Ice buildup inside unit. Follow de-icing instructions.
			X		X	Ground too hard or too soft. Re-evaluate application.
		X		X		Deteriorated shock absorber. Replace shock absorber.
X				X		Excessive internal clearances. Replace body, striker, or valve.
		X		X		Improper lubrication. Follow lubrication instructions.
X						Foreign material inside unit. Disassemble & clean.
X				X		Broken/misaligned internal parts. Disassemble, then repair or replace.
X				X		Rusted or rough sliding surfaces. Disassemble, clean and polish.
	X		X		X	Hit obstacle. Reverse tool from hole and retry.

SECTION 13.0 HOLE-HOG STORAGE

13.1 Short Term Field Storage

1. Clean exterior.
2. Clean out whip hose connection to the valve stem.
3. Lubricate interior of unit.
4. Wipe surface of unit with an oily rag to leave a thin coating of oil over the whole unit.
5. Position or tie whip hose in a manner to prevent it from being crushed.
6. Secure unit in a dry storage area or cover with a waterproof tarp.

13.2 Long Term Storage

1. Refer to Section 8.0 and disassemble the body/anvil from the end cap. Remove the striker.
2. Clean and inspect these components for damage and excessive wear.
3. Schedule replacement and repairs so unit will be ready to use after storage
4. Thoroughly clean all disassembled parts.
5. Lubricate all parts and reassemble.
6. Store in a protected, dry area.
7. Avoid wet or damp conditions to minimize rust.

**SECTION 14.0
PARTS & WARRANTY INFORMATION**

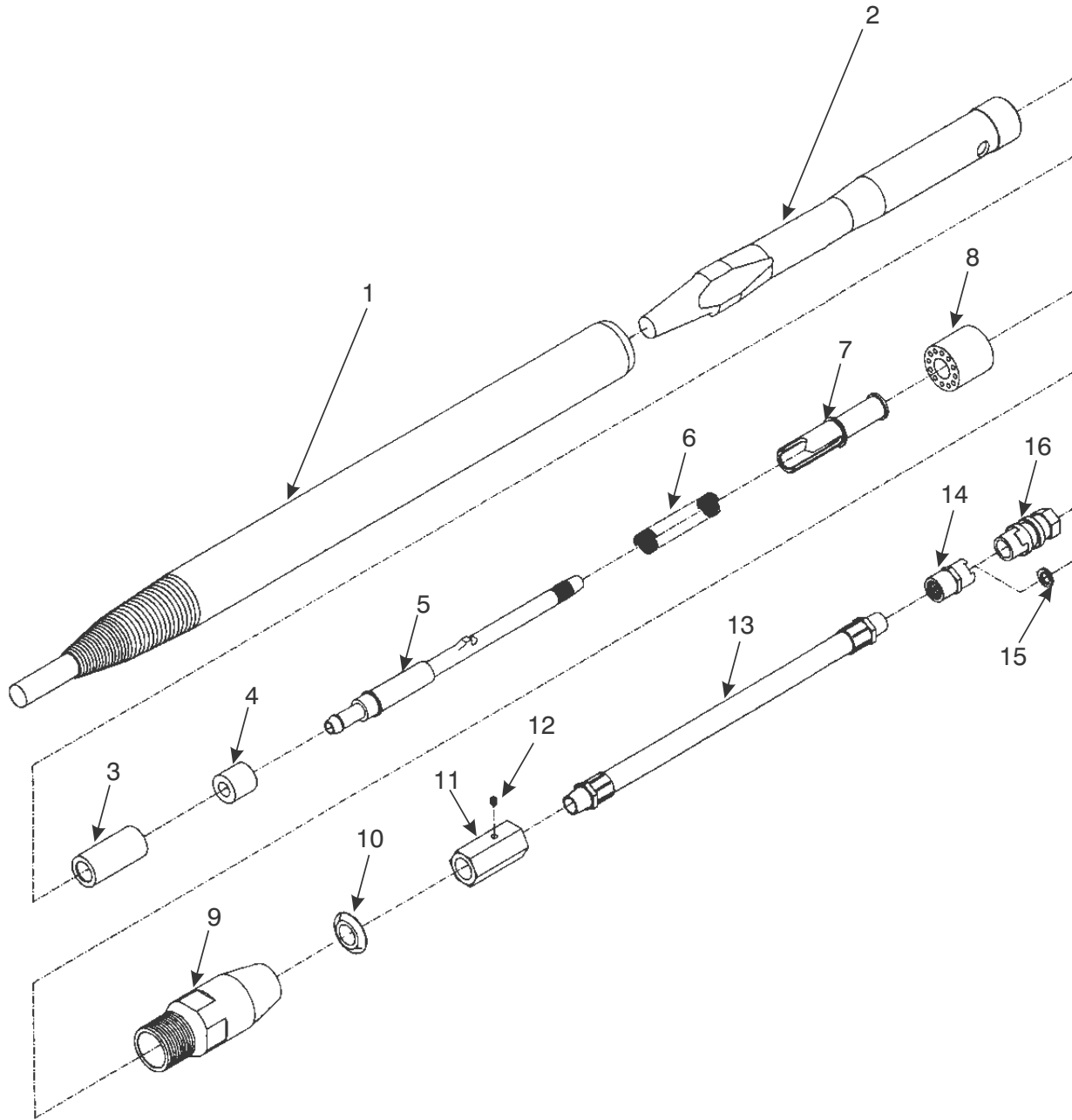

Figure 14-1. Model 2100C Hole-Hog Complete Assembly

Model 2100C Hole-Hog Complete Assembly Part No. 832100			
ITEM NO.	QTY.	PART NO.	DESCRIPTION
1	1	832120	Body/Anvil
2	1	832001	Striker
3	1	832706	Valve
4	1	832716	Valve Bushing
5	1	832804	Valve Stem
6	1	832824	Spring
7	1	832805	Valve Guide
8	1	832857	Shock Absorber
9	1	832156	End Cap
10	1	832513	Valve Seal
11	1	832139	Adapter
12	1	832140	Set Screw
13	1	832138	Whip Hose
14	1	833092	Socket, Quick Disconnect Coupling (Includes Item 15)
15	1	833088	Gasket, Quick Disconnect Coupling/Socket
16	1	833093	Plug, Quick Disconnect Coupling

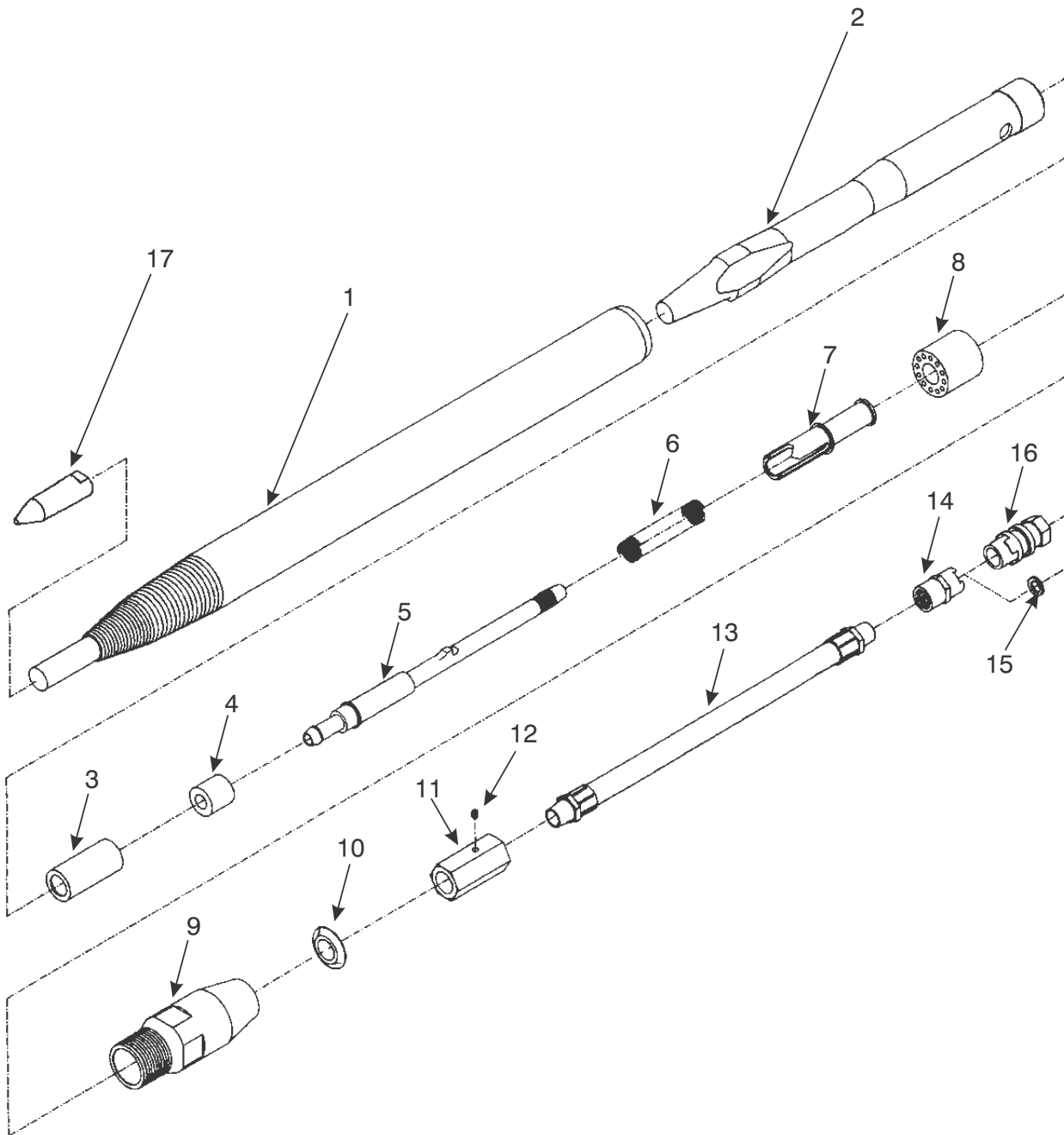

Figure 14-2. Model 2100C-TH Hole-Hog Complete Assembly

Model 2100C-TH Hole-Hog Complete Assembly Part No. 832119			
ITEM NO.	QTY.	PART NO.	DESCRIPTION
1	1	832104	Body/Anvil/Cap
2	1	832001	Striker
3	1	832706	Valve
4	1	832716	Valve Bushing
5	1	832804	Valve Stem
6	1	832824	Spring
7	1	832805	Valve Guide
8	1	832857	Shock Absorber
9	1	832156	End Cap
10	1	832513	Valve Seal
11	1	832139	Adapter
12	1	832140	Set Screw
13	1	832138	Whip Hose
14	1	833092	Socket, Quick Disconnect Coupling (Includes Item 15)
15	1	833088	Gasket, Quick Disconnect Coupling/Socket
16	1	833093	Plug, Quick Disconnect Coupling
17	1	833022	Anvil Cap

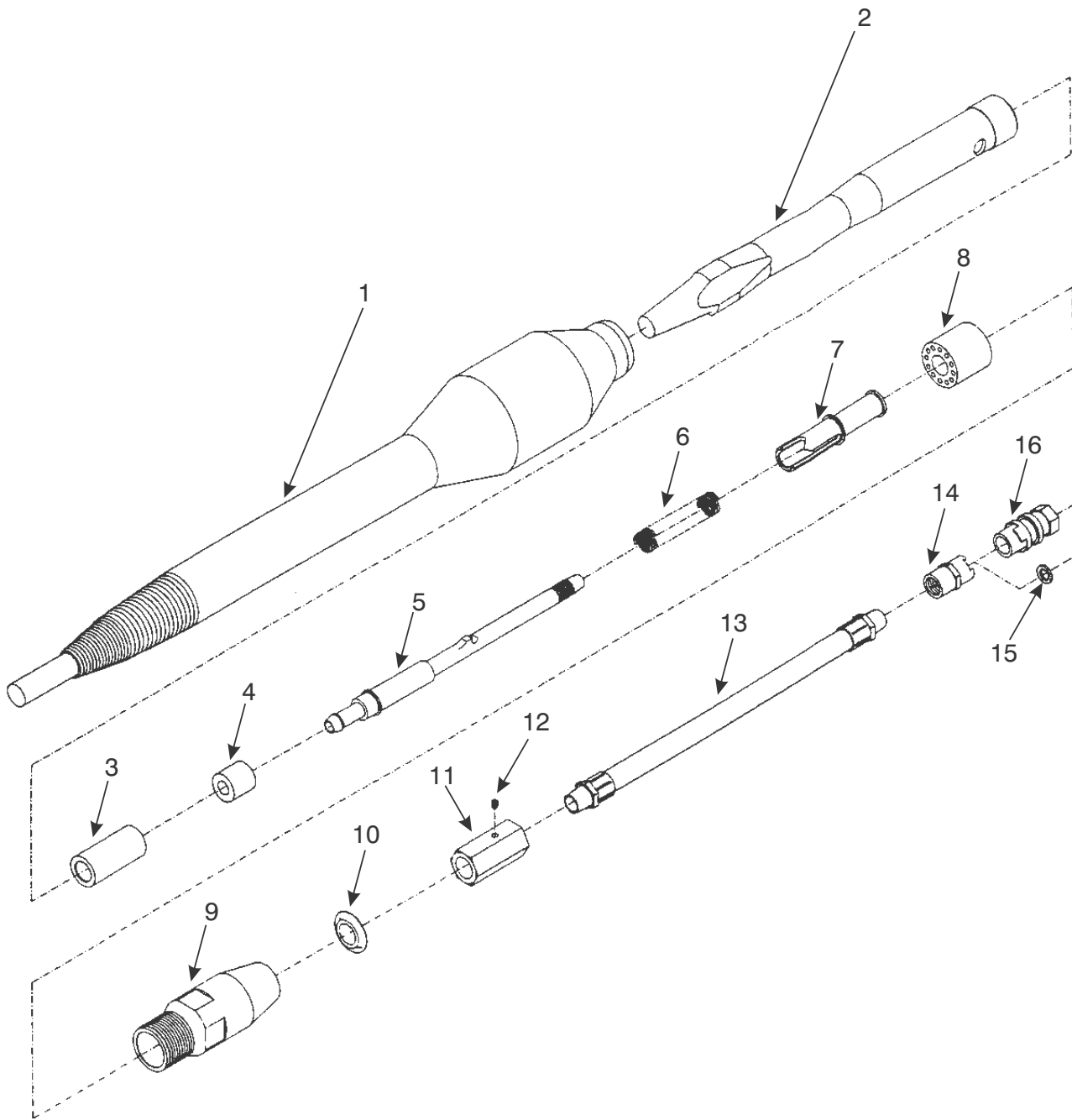

Figure 14-3. Model 2101C Hole-Hog Complete Assembly

Model 2101C Hole-Hog Complete Assembly Part No. 832117			
ITEM NO.	QTY.	PART NO.	DESCRIPTION
1	1	833601	Body/Anvil
2	1	832001	Striker
3	1	832706	Valve
4	1	832716	Valve Bushing
5	1	832804	Valve Stem
6	1	832824	Spring
7	1	832805	Valve Guide
8	1	832857	Shock Absorber
9	1	832156	End Cap
10	1	832513	Valve Seal
11	1	832139	Adapter
12	1	832140	Set Screw
13	1	832138	Whip Hose
14	1	833092	Socket, Quick Disconnect Coupling (Includes Item 15)
15	1	833088	Gasket, Quick Disconnect Coupling/Socket
16	1	833093	Plug, Quick Disconnect Coupling

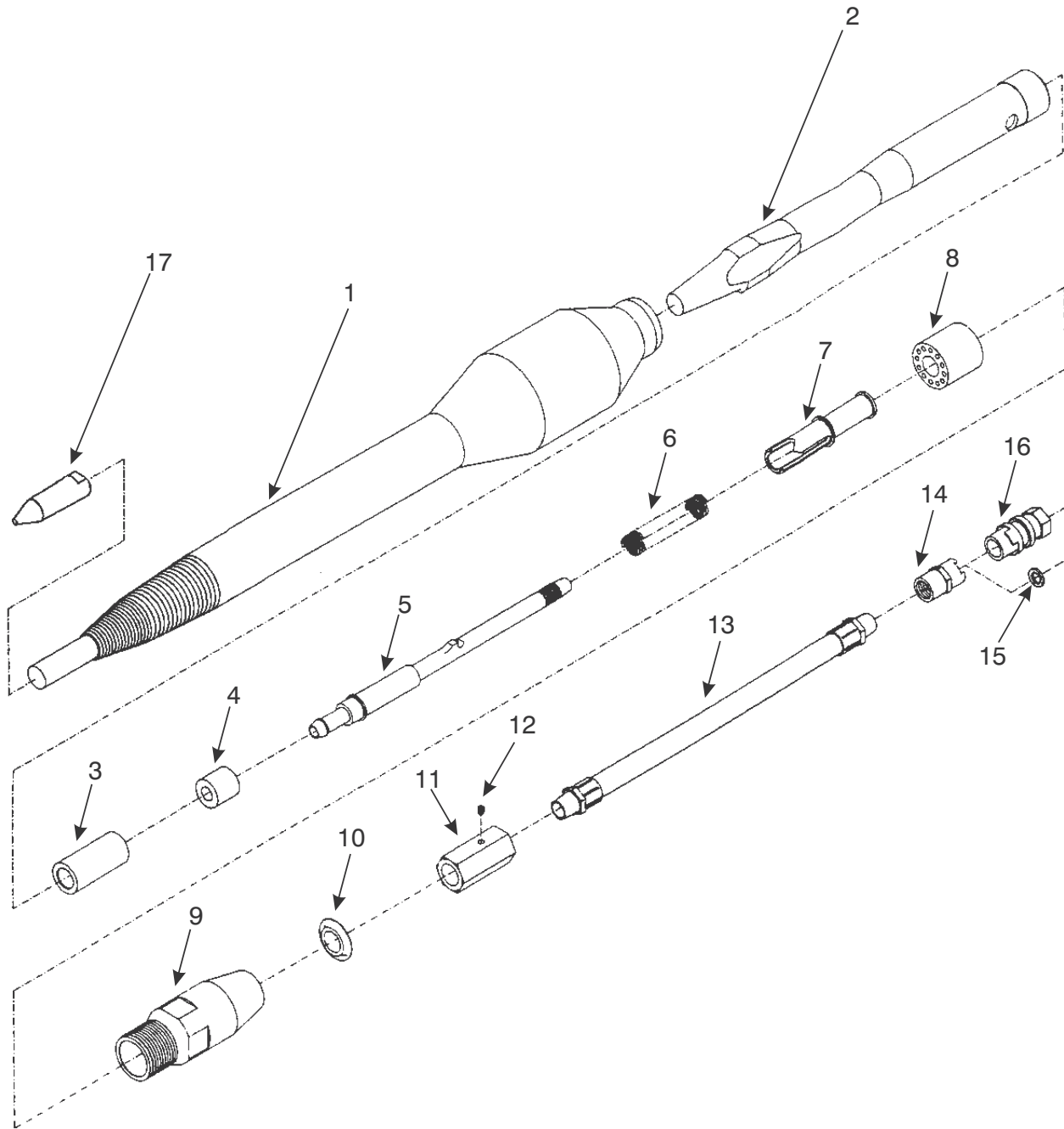

Figure 14-4. Model 2101C -TH Hole-Hog Complete Assembly

Model 2101C-TH Hole-Hog Complete Assembly Part No. 832121			
ITEM NO.	QTY.	PART NO.	DESCRIPTION
1	1	832118	Body/Anvil/Cap
2	1	832001	Striker
3	1	832706	Valve
4	1	832716	Valve Bushing
5	1	832804	Valve Stem
6	1	832824	Spring
7	1	832805	Valve Guide
8	1	832857	Shock Absorber
9	1	832156	End Cap
10	1	832513	Valve Seal
11	1	832139	Adapter
12	1	832140	Set Screw
13	1	832138	Whip Hose
14	1	833092	Socket, Quick Disconnect Coupling (Includes Item 15)
15	1	833088	Gasket, Quick Disconnect Coupling/Socket
16	1	833093	Plug, Quick Disconnect Coupling
17	1	833022	Anvil Cap

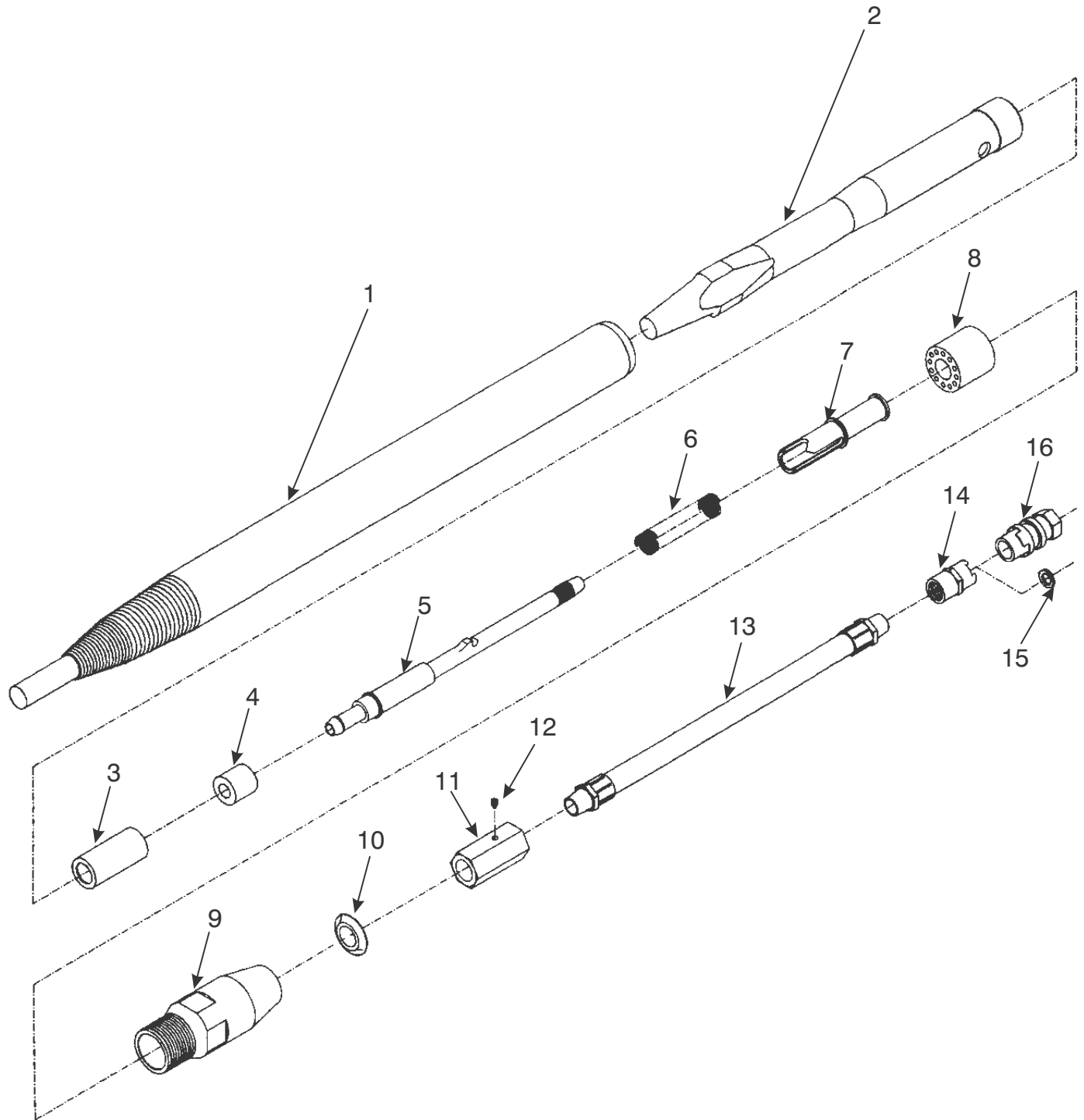

Figure 14-5. Model 2501C Hole-Hog Complete Assembly

Model 2501C Hole-Hog Complete Assembly Part No. 832501			
ITEM NO.	QTY.	PART NO.	DESCRIPTION
1	1	832620	Body/Anvil/
2	1	832001	Striker
3	1	832706	Valve
4	1	832716	Valve Bushing
5	1	832804	Valve Stem
6	1	832824	Spring
7	1	832805	Valve Guide
8	1	832857	Shock Absorber
9	1	832156	End Cap
10	1	832513	Valve Seal
11	1	832139	Adapter
12	1	832140	Set Screw
13	1	832138	Whip Hose
14	1	833092	Socket, Quick Disconnect Coupling (Includes Item 15)
15	1	833088	Gasket, Quick Disconnect Coupling/Socket
16	1	833093	Plug, Quick Disconnect Coupling

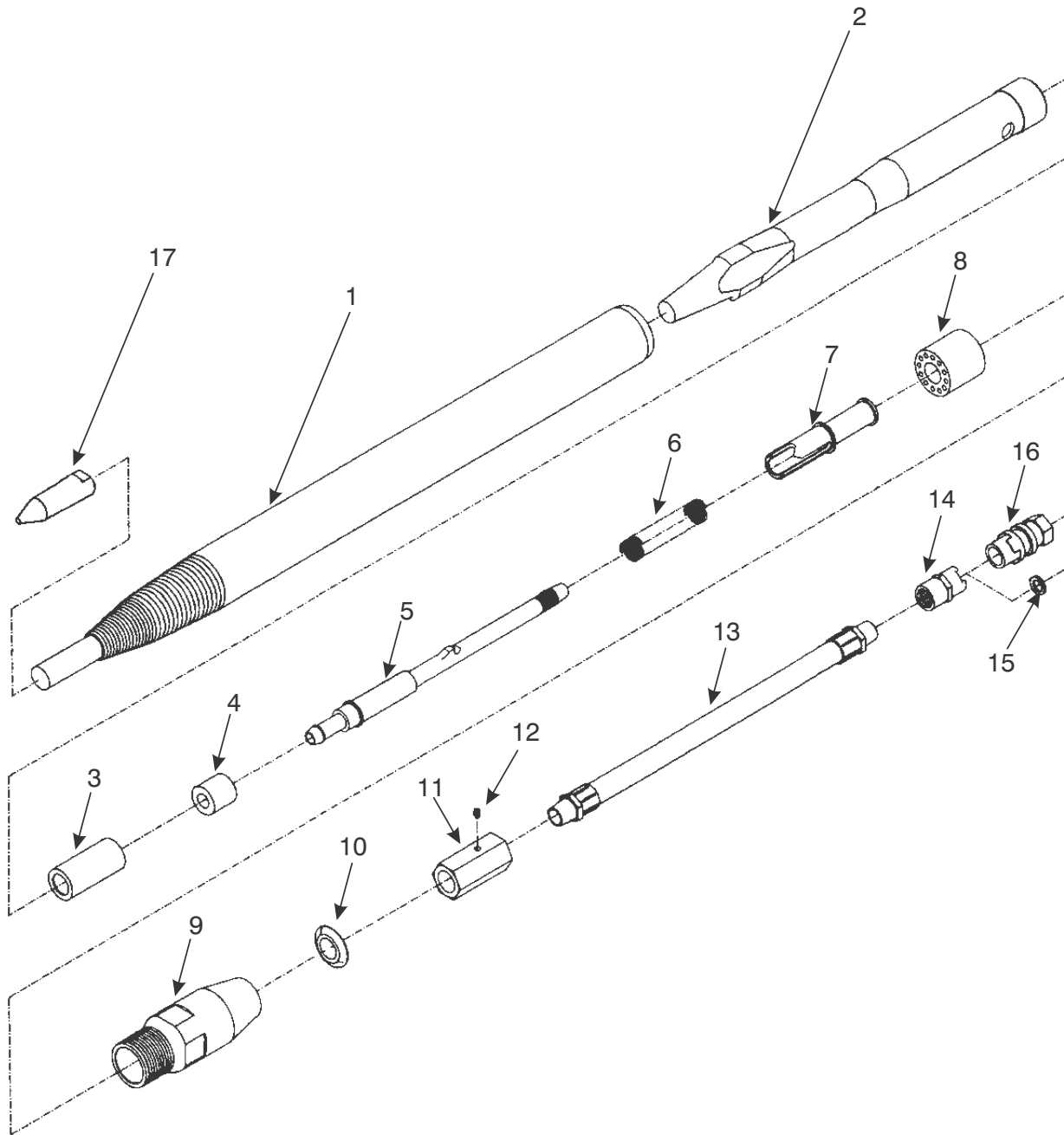

Figure 14-6. Model 2501C-TH Hole-Hog Complete Assembly

Model 2501C-TH Hole-Hog Complete Assembly Part No. 832501			
ITEM NO.	QTY.	PART NO.	DESCRIPTION
1	1	832504	Body/Anvil/Cap
2	1	832001	Striker
3	1	832706	Valve
4	1	832716	Valve Bushing
5	1	832804	Valve Stem
6	1	832824	Spring
7	1	832805	Valve Guide
8	1	832857	Shock Absorber
9	1	832156	End Cap
10	1	832513	Valve Seal
11	1	832139	Adapter
12	1	832140	Set Screw
13	1	832138	Whip Hose
14	1	833092	Socket, Quick Disconnect Coupling (Includes Item 15)
15	1	833088	Gasket, Quick Disconnect Coupling/Socket
16	1	833093	Plug, Quick Disconnect Coupling
17	1	833022	Anvil Cap

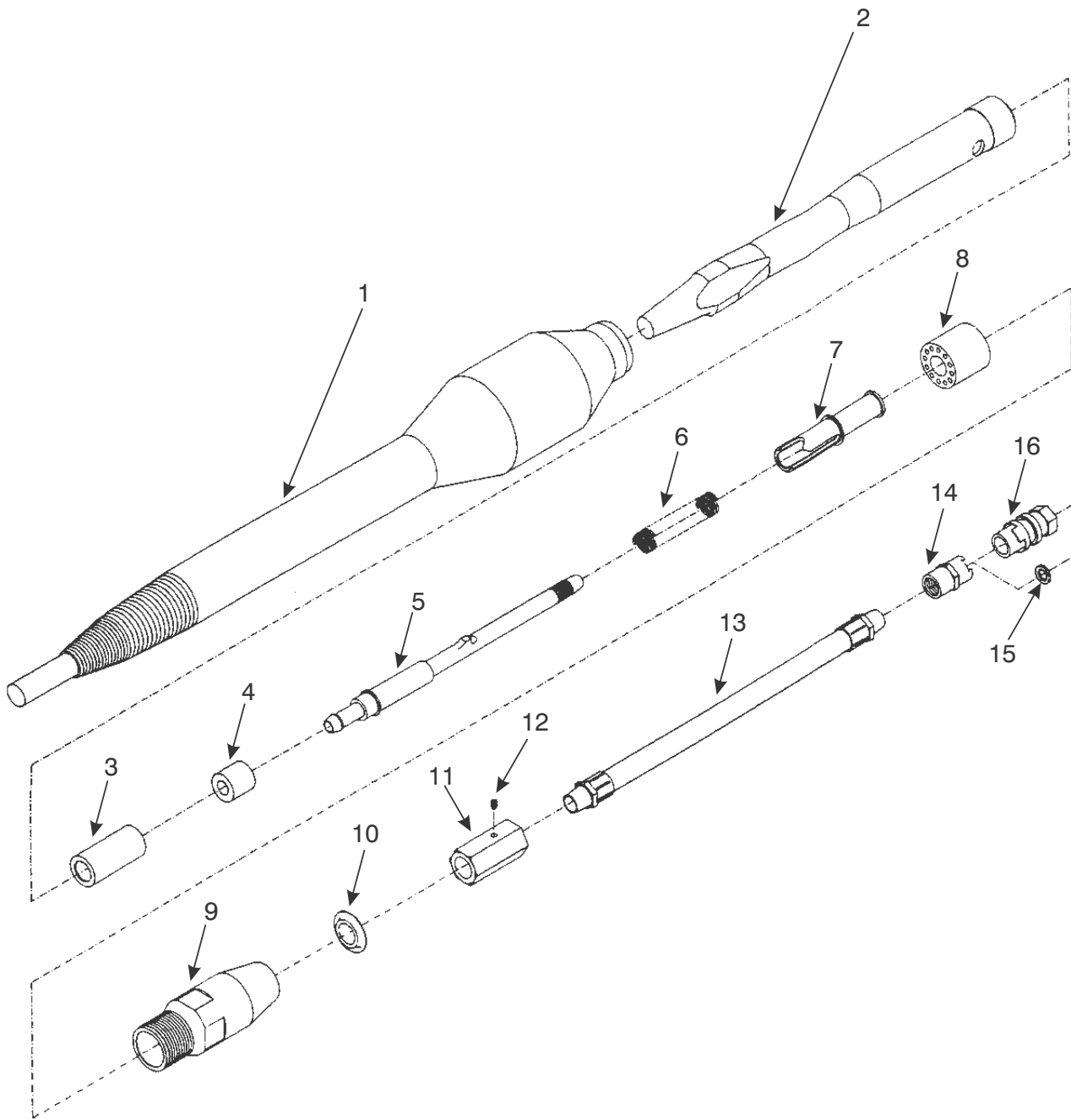

Figure 14-7. Model 2502C Hole-Hog Complete Assembly

Model 2502C Hole-Hog Complete Assembly Part No. 832510			
ITEM NO.	QTY.	PART NO.	DESCRIPTION
1	1	832511	Body/Anvil/
2	1	832001	Striker
3	1	832706	Valve
4	1	832716	Valve Bushing
5	1	832804	Valve Stem
6	1	832824	Spring
7	1	832805	Valve Guide
8	1	832857	Shock Absorber
9	1	832156	End Cap
10	1	832513	Valve Seal
11	1	832139	Adapter
12	1	832140	Set Screw
13	1	832138	Whip Hose
14	1	833092	Socket, Quick Disconnect Coupling (Includes Item 15)
15	1	833088	Gasket, Quick Disconnect Coupling/Socket
16	1	833093	Plug, Quick Disconnect Coupling

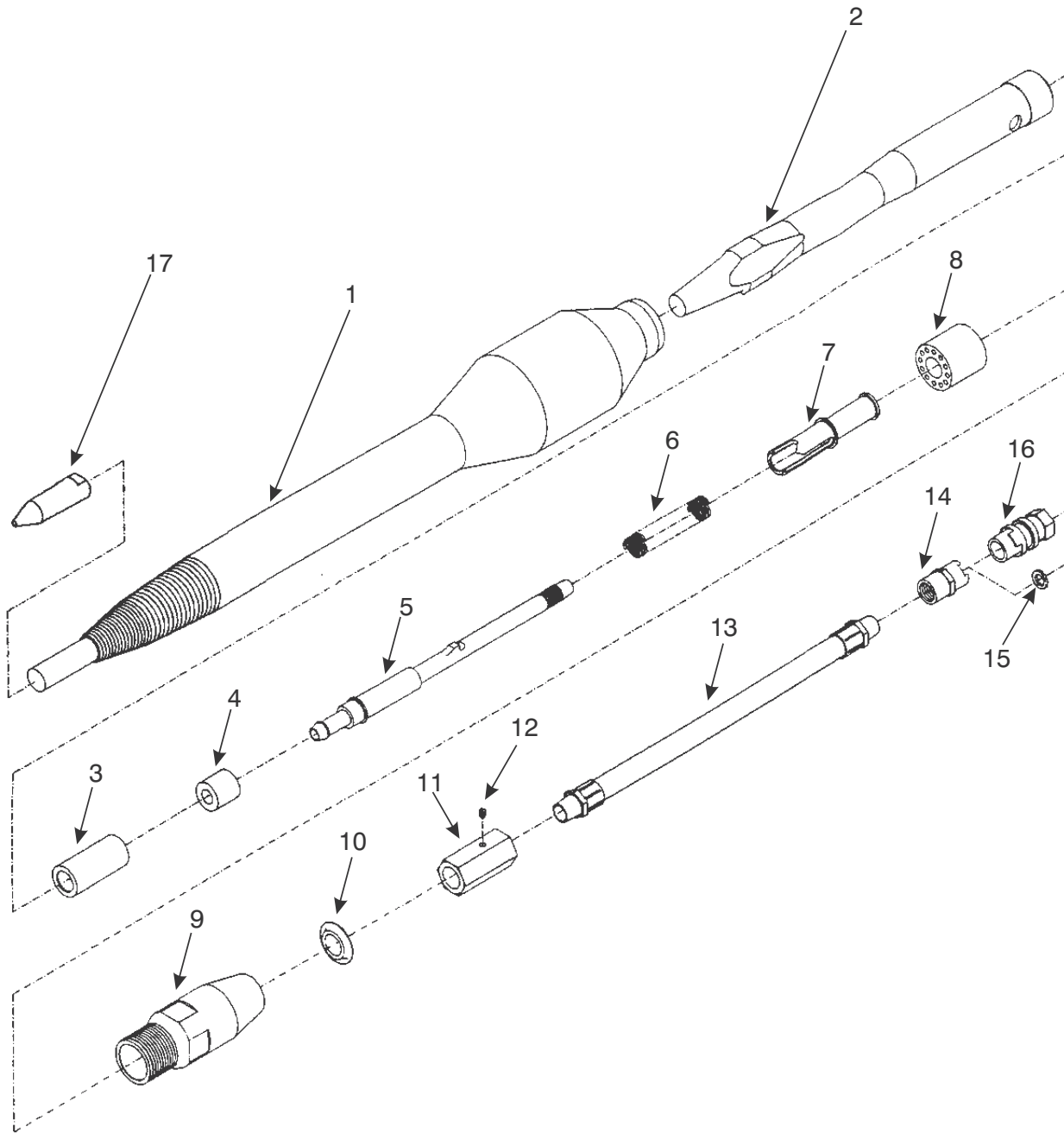

Figure 14-8. Model 2501C-TH Hole-Hog Complete Assembly

Model 2502C-TH Hole-Hog Complete Assembly Part No. 832516			
ITEM NO.	QTY.	PART NO.	DESCRIPTION
1	1	832515	Body/Anvil/Cap
2	1	832001	Striker
3	1	832706	Valve
4	1	832716	Valve Bushing
5	1	832804	Valve Stem
6	1	832824	Spring
7	1	832805	Valve Guide
8	1	832857	Shock Absorber
9	1	832156	End Cap
10	1	832513	Valve Seal
11	1	832139	Adapter
12	1	832140	Set Screw
13	1	832138	Whip Hose
14	1	833092	Socket, Quick Disconnect Coupling (Includes Item 15)
15	1	833088	Gasket, Quick Disconnect Coupling/Socket
16	1	833093	Plug, Quick Disconnect Coupling
17	1	833022	Anvil Cap

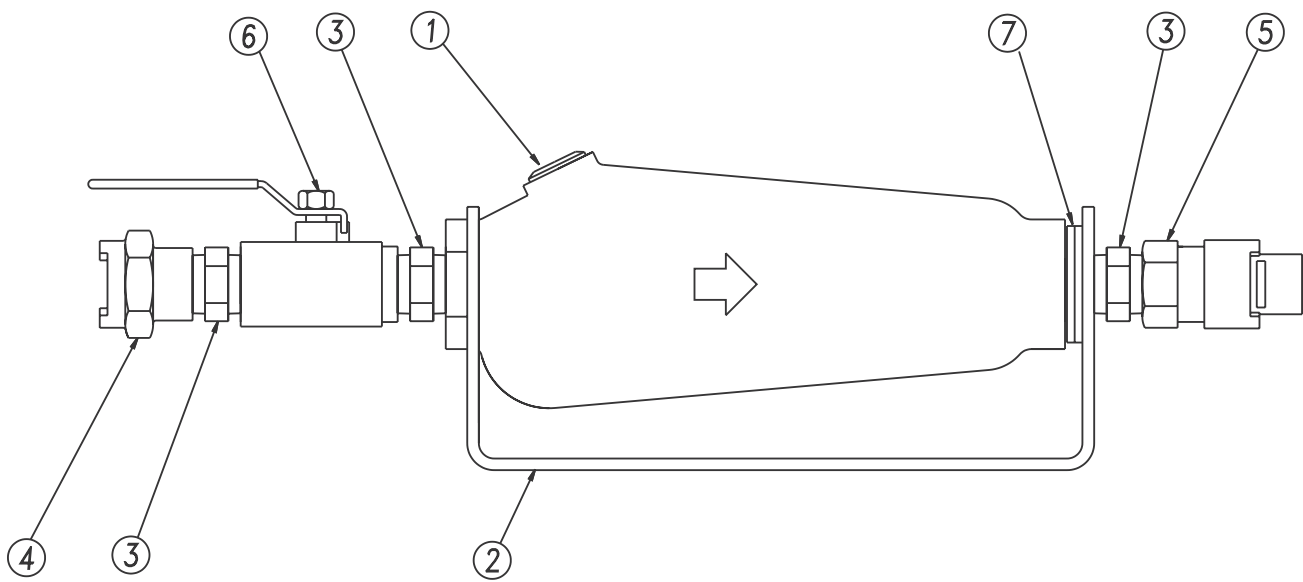

Figure 14-9. Air Line Lubricator Assembly

Model 2100 and 2500 Series Hole-Hog Air Line Lubricator Assembly (Accessory) Part No. 832024			
ITEM NO.	QTY.	PART NO.	DESCRIPTION
1	1	832019	In-Line Air Lubricator 1"
2	1	832021	Support Bracket
3	3	798172	Pipe Nipple
4	1	833092	Quick Disconnect Coupling - Socket 1"
5	1	833093	Quick Disconnect Coupling - Plug 1"
6	1	837099	Ball Valve
7	2	658919	Shim
			FOR USE WITH AIR LINE LUBRICATOR
		832240	Hog Wash, 1 quart
		832219	Hog Wash, 4 quart case
		832220	Hog Wash, 5 gallons



3900 Kelley Avenue, Cleveland, Ohio 44114
Tel: 216-431-2600 Fax: 216-431-2601
e-mail: Sales@AlliedCP.com
website: <http://www.AlliedCP.com>
