

ALLIED
Construction Products, LLC

**TECHNICAL
MANUAL**

*Manual Part Number 002001
July 25, 2003*



**8700C
SERIES
HO-PAC**

**Allied Ho-Pac Model 8700C Series
Document Change Notice**

<u>Date</u>	<u>Page</u>	<u>Change</u>
8-27-99	Cover	New Design
8-27-99	38,,40,44	Art
8-27-99	39,41,43,45	Parts Lists
1-8-01	Throughout	Added new types
1-8-01	Throughout	Editing changes/rewrites
1-8-01	7 & 8	Updated Specs and Dimensions
1-8-01	9,10,11,12	Dimension Drawings
1-8-01	14,16,18,20	Decal Drawings
1-8-01	15,17,19,21	Decal Parts Lists
1-8-01	44,46,48,50	Parts Drawings
1-8-01	45,47,49,51	Parts Lists
5-03-02	All	Update to Current Product and Documentation Standards
7-25-03	66	Corrected Motor & Valve Pkg list

TABLE OF CONTENTS

Section	Page
SECTION 1.0 INTRODUCTION	1
1.1 Safety Information.	1
1.2 Warranty Information.	1
1.3 Allied Product Policies.	2
SECTION 2.0 OVERVIEW	3
SECTION 3.0 PRINCIPLES OF OPERATION	4
SECTION 4.0 TECHNICAL INFORMATION	5
4.1 SPECIFICATIONS	
4.2 DIMENSION DIAGRAMS	7
4.3 DECAL IDENTIFICATION.	15
4.4 DECAL, LIFTING AND LUBRICATION DIAGRAMS.	16
SECTION 5.0 MOUNTING INFORMATION.	30
5.1 VMS Mounting	30
5.2 BCS and SCS Mounting	31
5.3 BSF Pin-On Mounting	32
5.4 Swivel Mount	33
SECTION 6.0 GENERAL CONSTRUCTION SAFETY	34
6.1 Owner's Responsibilities	34
6.2 General Construction Safety.	34
6.3 Federal, State, Local and OSHA Construction Guidelines and Regulations	34
6.4 General Safety Summary	34
6.4.1 CAUTIONS and WARNINGS.	34
6.4.2 Personnel Precautions.	35
SECTION 7.0 CARRIER APPLICATION	36
SECTION 8.0 INSTALLATION & REMOVAL	37
8.1 Installation	37
8.2 Removal.	38
SECTION 9.0 OPERATION	39
SECTION 10.0 TROUBLESHOOTING	41

TABLE OF CONTENTS (continued)

Section	Page
SECTION 11.0 SERVICE AND MAINTENANCE	42
11.1 General Guidelines	42
11.2 Daily Maintenance	42
11.3 Preventive Maintenance	42
11.4 Conditional Maintenance	42
11.5 Lubrication	43
11.6 Bolts	43
11.7 Bearing Failure & Replacement	44
11.8 Spring Mounts	44
11.9 Hydraulic Motor	45
11.10 Warranty Protection.	45
SECTION 12.0 LIFTING & TRANSPORT	46
SECTION 13.0 STORAGE	47
SECTION 14.0 PARTS INFORMATION	49

SECTION 1.0 INTRODUCTION

Ho-Pac Technical Manual: Part Number 002001

This Technical Manual is applicable to Ho-Pac:

Model: 8700C series

Serial Numbers: 7348 and above

Years of Manufacture: 1994 and beyond

Serial Number(s) _____

The model and serial numbers are located on the ID Plate mounted on the Ho-Pac as shown in Section 4.4 Decal, Lifting and Lubrication Diagrams.

This manual contains important information for the safe use and maintenance of the Allied Ho-Pac. Read this manual thoroughly before installing, operating or servicing the Ho-Pac. This manual must be easily accessible to operators, or service and transport personnel. Store this manual in a convenient location.

Pay careful attention to all instructions and follow all governing regulations. Operation or service other than in accordance with these instructions may subject the Ho-Pac to conditions beyond its design capability. Improper operation, service or the use of non-Allied parts may result in Ho-Pac failure or personnel injury.

1.1 Safety Information

When using the Ho-Pac, safety procedures must be followed. See Section 4.0 for further safety guidelines.

Pay particular attention to WARNINGS and CAUTIONS, identified with this symbol.



These instructions are important for personnel safety and full service life of the Ho-Pac. Follow them carefully.

1.2 Warranty Information

Warranty coverage of the Allied Ho-Pac depends on proper maintenance and operation of the Ho-Pac as detailed in this manual. Improper maintenance or operation shall void Ho-Pac warranty coverage.

Immediately upon receipt of the Ho-Pac, read all Allied warranty documents delivered with the unit for a thorough understanding of warranty coverage.

Record the Ho-Pac Serial Number in the space provided above.

1.3 Allied Product Policies

Allied reserves the right to make modifications to the design or changes to the specifications without prior notice.

In this manual, Allied recommends Ho-Pac applications, maintenance and service consistent with industry practices. Allied takes no responsibility for the results of actions not recommended in this manual and specifically the results of:

- Operation in non-recommended applications
- Incorrect operation
- Improper maintenance
- Use of service parts not approved or supplied by Allied.

These exclusions apply to damage to the Ho-Pac, associated equipment, and injury to personnel.

SECTION 2.0 OVERVIEW

The Allied Ho-Pac is a boom-mounted, hydraulic powered, vibrating plate compactor and driver. It is used for soil compaction and sheet/pile installation. The Ho-Pac is typically mounted on either a rubber tired or track construction vehicles.

The Allied 8700C Ho-Pac can compact up to 4 foot lifts of granular materials and up to 3 foot lifts of loose clay soils to densities of 95% Proctor. Soils with moisture contents near their maximum density improve compaction effectiveness.

The Allied Ho-Pac vibrational compactor consists of the following major subassemblies:

The DYNAMIC ASSEMBLY includes the hydraulic motor, bearings, eccentric mass, housing frame and base plate. This assembly generates and transfers the vibratory energy to the soil.

The SUSPENSION SYSTEM has spring mounts that suspend and isolate the Dynamic Assembly from the Mounting Frame.

The MOUNTING FRAME houses the Suspension System and mounts to the boom of the carrier.

SECTION 3.0 PRINCIPLES OF OPERATION

The Allied Ho-Pac is a high energy compaction tool utilizing three compaction techniques:

- The **IMPULSE FORCE** generated by the rotating eccentric mass vibrates the soil near the base plate to eliminate voids between material particles.
- The **VIBRATION FREQUENCY** of 2000 r.p.m. provides maximum effectiveness for the consolidation and compaction of granular soil materials.
- The **DOWN FORCE** of the carrier provides a preload force to effectively transfer the vibrating energy and to compress the material.

Optimum compaction is usually obtained with two passes. The duration of the initial pass is dependent on depth and material. The second pass may require additional fill material and Ho-Pac repositioning to achieve a finished surface.

The Allied Ho-Pac can also be an effective sheet or pile driver. The Ho-Pac's vibrational energy is transferred through the sheet or pile to the soil. Sandy soils and moist clays are "softened" by the vibration which allows the sheet or pile to penetrate more easily.

**SECTION 4.0
TECHNICAL INFORMATION**

4.1 SPECIFICATIONS

The following specifications apply to all configurations of the 8700C Ho-Pac. Table 4-1 on the next page contains dimensions specific to each configuration.

Impulse Force	6400 lbs (28,500N)		
Cycles per Minute	2000		
Sound Power Level	99 dBA (LWA)		
Hydraulic Flow & Pressure	Recommended Flow	Max.Opr Pres.	
Motor Options	gpm	lpm	psi bar
	12	45	2800 193
	18	68	2000 138
	21	79	2000 138
Operating Pressure - No Load	300-500 psi (20-35 bar)		
Hydraulic Capacity	0.3 gal (1.2 l) Approximate		

Baseplate

Dimensions	24 inch x 28 inch (61cm x 69cm)
Compaction Area	4.7 ft ² (0.43 m ²)

Hydraulic Hose Size

Pressure Line	3/4 inch diameter (19 mm)
Return Line	3/4 inch diameter (19 mm)

Recommended Carrier Weights

Backhoe	9,000-25,000 lbs (4,000-11,000 kg)
Excavator	14,000-30,000 lbs. (6,000-14,000 kg)

Table 4-1. 8700C Ho-Pac Dimensions							
	STD*	BSF	BSF With Swivel**	Flat Top Custom	Flat Top SCS	Flat Top BCS	VMS V10
Weight lbs (kg)	910 (413)	910 (413)	1105 (502)	950 (432)	915 (415)	910 (413)	985 (447)
Height in. (mm)	29.5 (749)	30.3 (770)	39.4 (1001)	28.4 (721)	26.1 (663)	26.3 (668)	30.3 (770)
Width in. (mm)	24.0 (610)	24.0 (610)	24.0 (610)	24.0 (610)	24.0 (610)	24.0 (610)	24.0 (610)
Depth in. (mm)	32.7 (831)	33.7 (856)	32.7 (856)	34.2 (869)	34.2 (869)	33.7 (856)	33.7 (856)
Mounting Pin Diameter in. (mm)	1.50 (38) 1.75 (44)	1.50 (38) 1.75 (44)	1.50 (38)	N/A	N/A	N/A	Multiple
Max Boom Width in. (mm)	10.3 (262)	10.3 (262)	10.3 (262)	N/A	N/A	N/A	10.6 (269)

*This model has been discontinued.

**Swivel attachment may be locked in 0, 45, and 90 degree positions.

4.2 DIMENSION DIAGRAMS

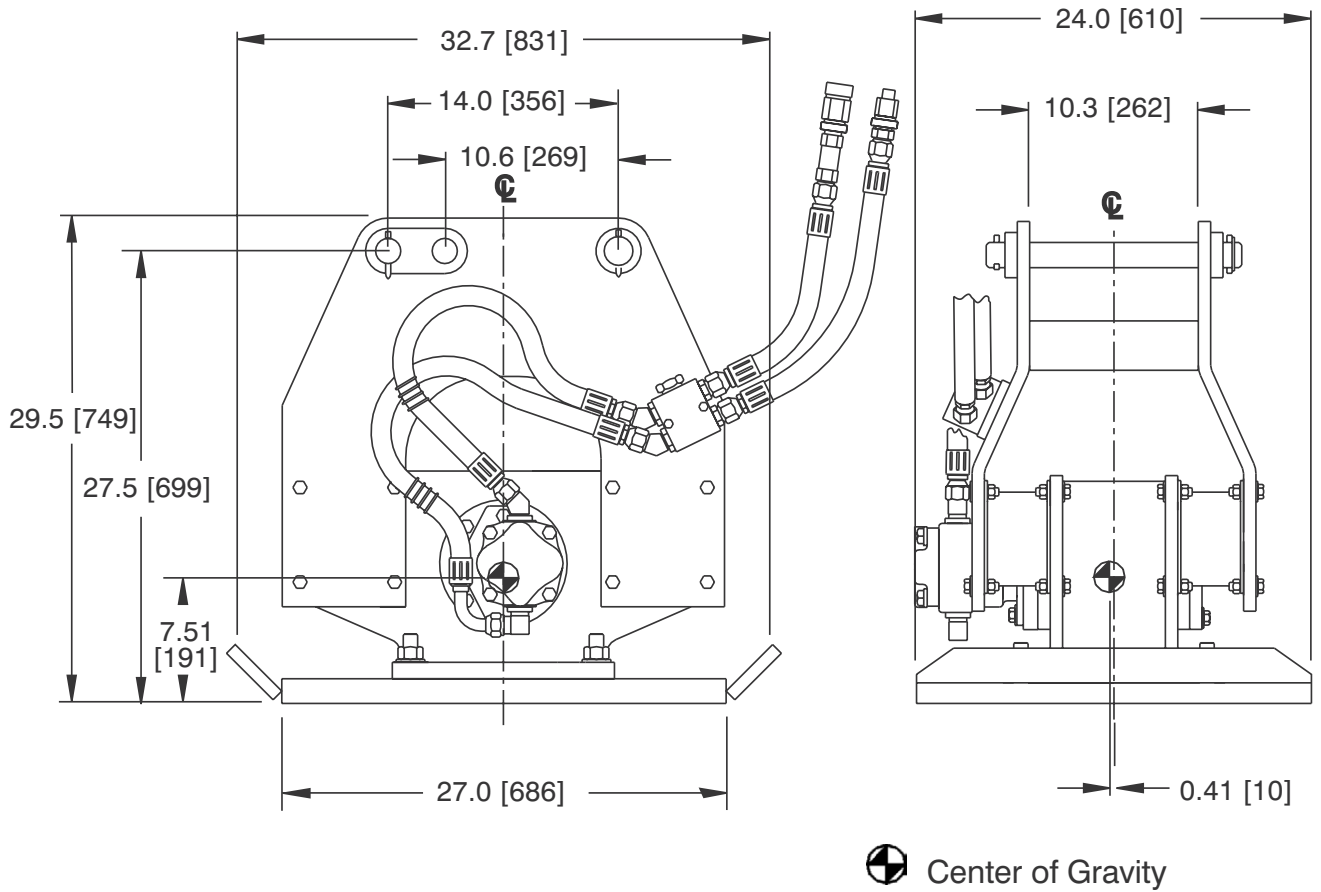

STD Ho-Pac Dimension Diagram
(This Model has been discontinued.)

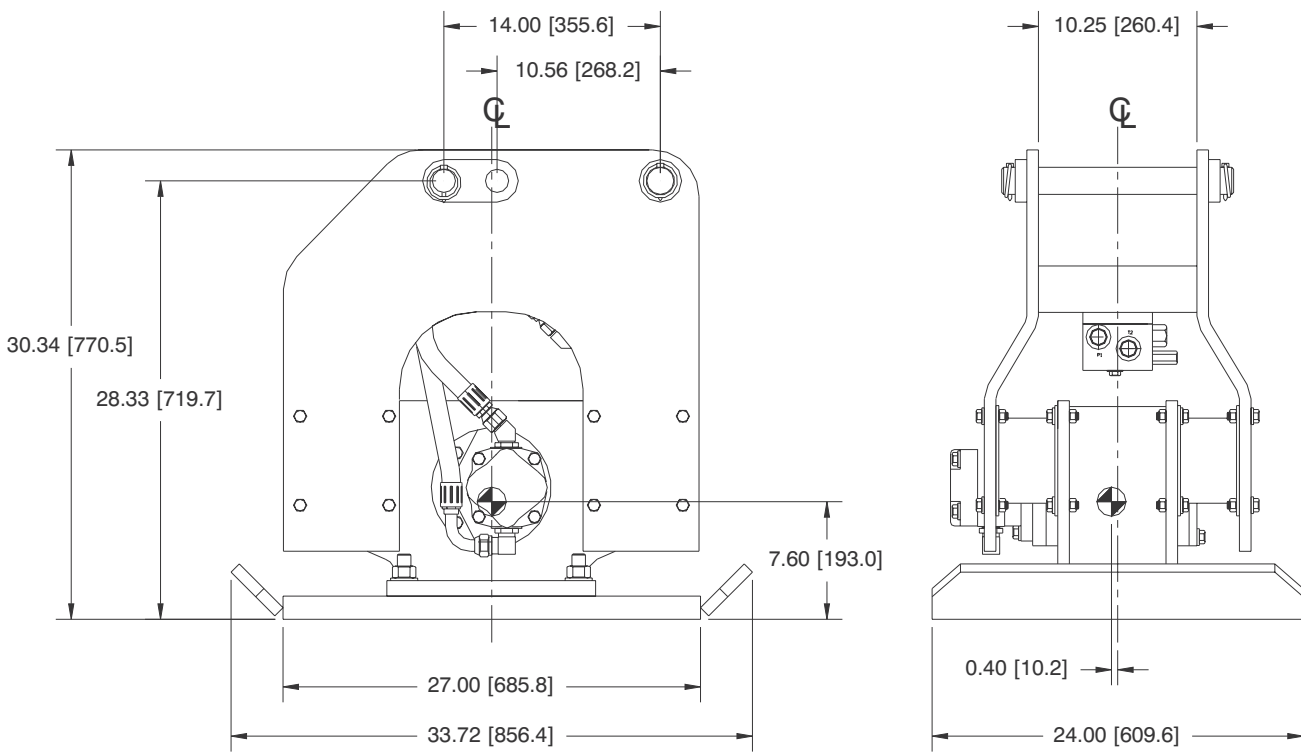

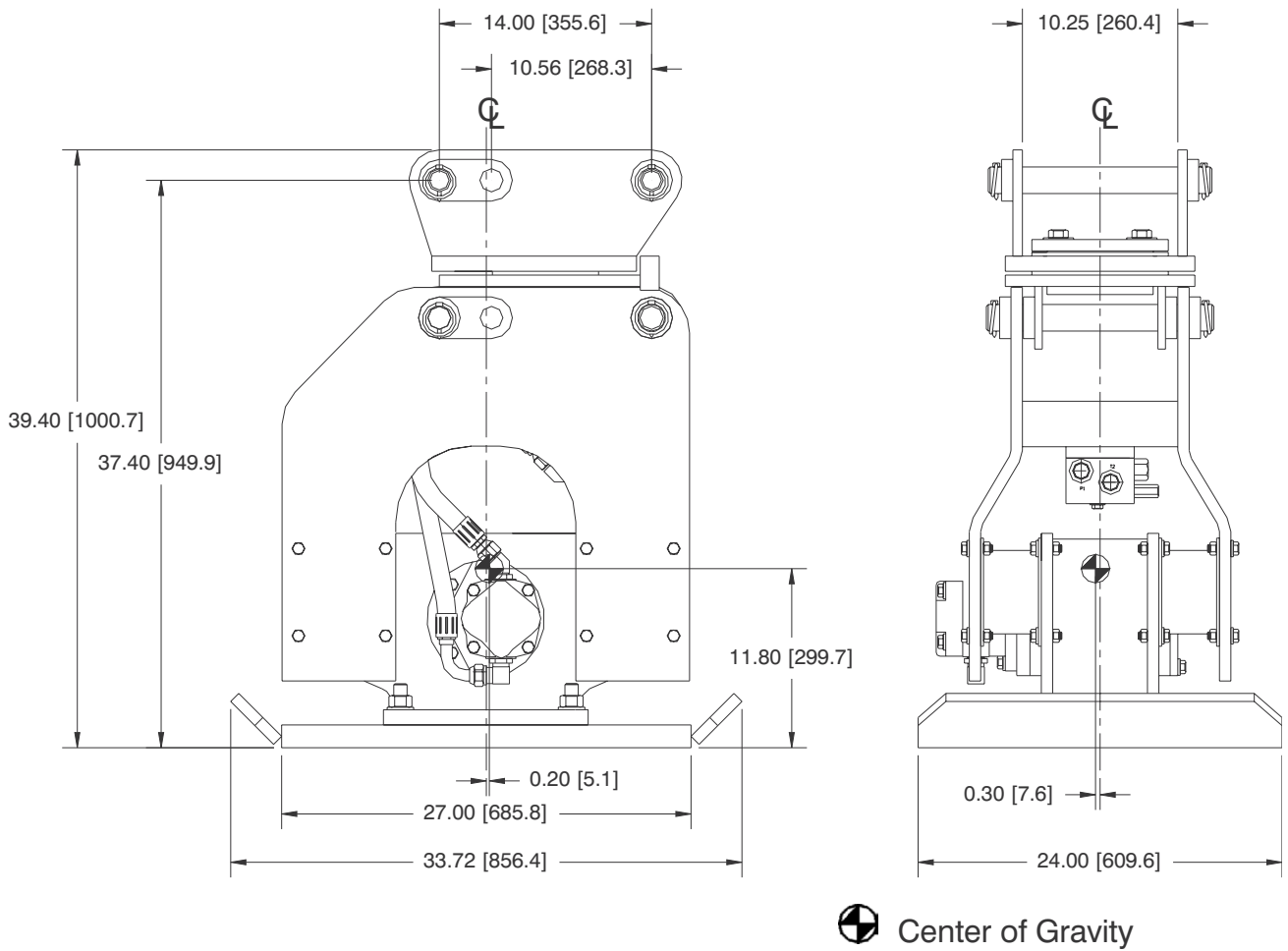

 Center of Gravity

BSF Ho-Pac Dimension Diagram



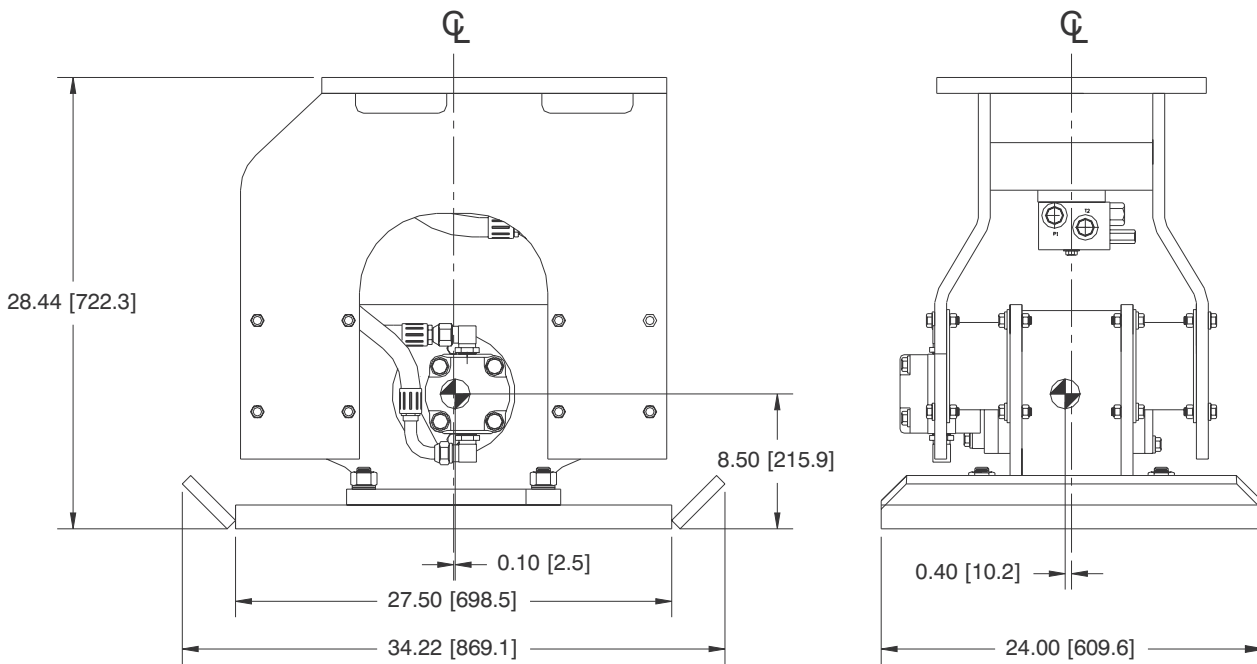

BSF Ho-Pac with Swivel Dimension Diagram

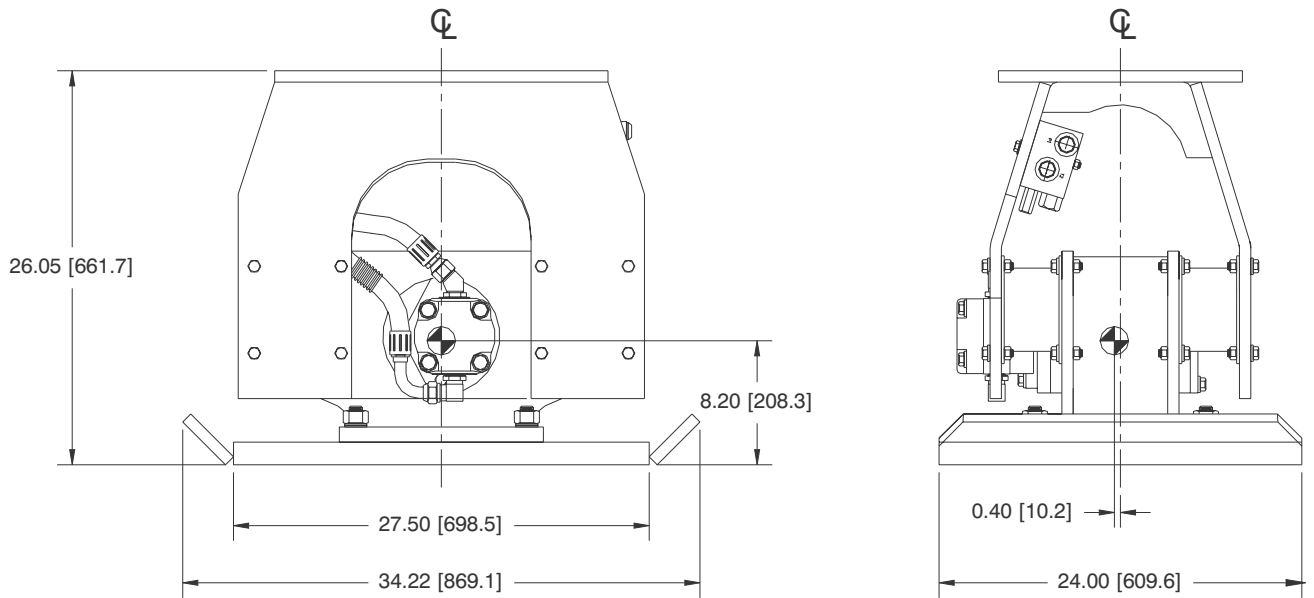

 Center of Gravity

Custom Flat Top Ho-Pac Dimension Diagram



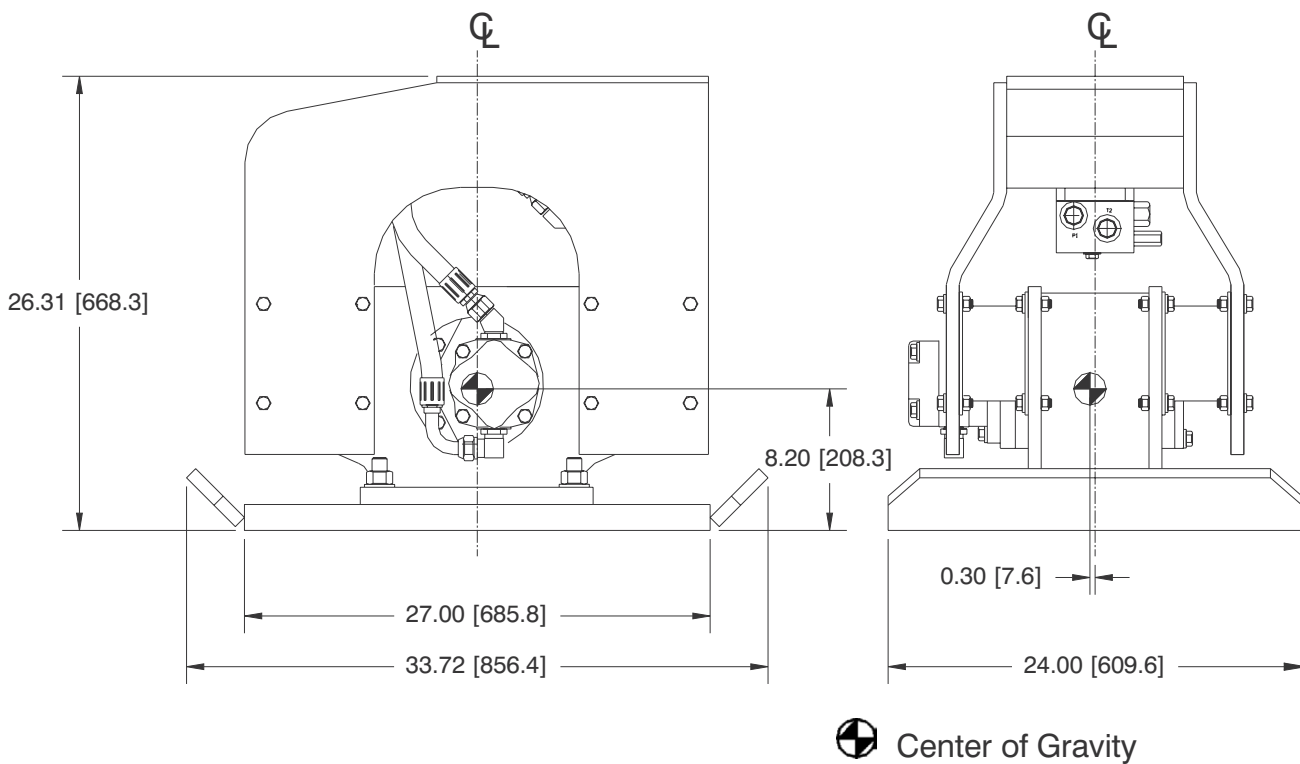

 Center of Gravity

SCS Flat Top Ho-Pac Dimension Diagram

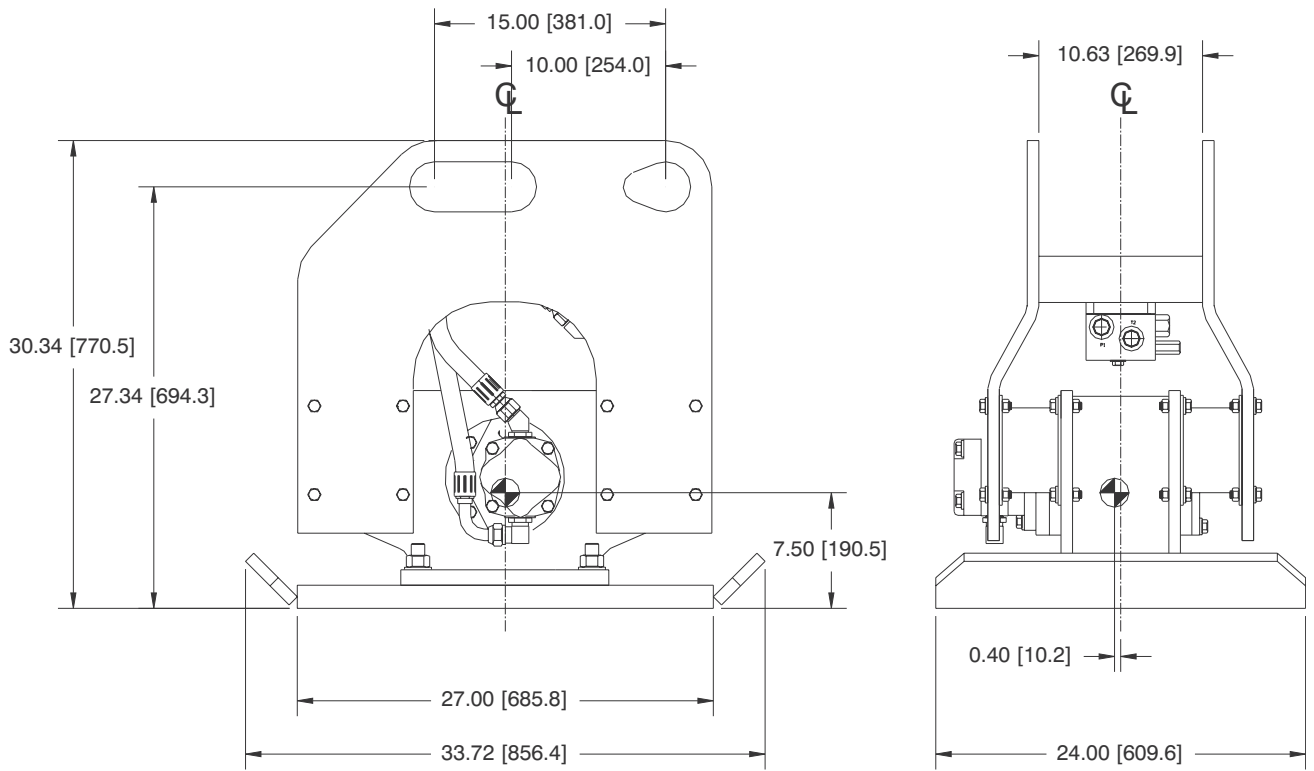

BCS Flat Top Ho-Pac Dimension Diagram



 Center of Gravity

VMS V10 Ho-Pac Dimension Diagram

This page intentionally
left blank.

4.3 DECAL IDENTIFICATION

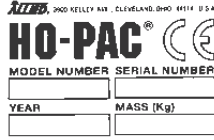

The ID PLATE (Identification Plate) contains the following information: Manufacturer’s name and address, Product Name, CE compliance marking, Model Number, Serial Number, Year of Manufacture, and Mass.



The LIFT POINT decal identifies the location of the recommended lifting points of the Ho-Pac.



The LUBRICATION decal identifies the location and frequency of required lubrication. Refer to Section 10.2 for more information.



The STAY CLEAR decal indicates that personnel and by-standers are to maintain a safe distance from the Ho-Pac during operation.



The READ INSTRUCTION decal indicates that it is important for the operator to read the manual prior to transporting, installing, operating, or servicing the Ho-Pac.



The HOT SURFACE decal indicates that the hydraulic components may be hot and that proper protective equipment is required. These components include the quick disconnect couplings, hoses, hose fittings, and hydraulic motor.



The ALLIED LOGO decal is the Allied brand identifier and is a registered trademark of Allied Construction Products, LLC.

4.4 DECAL, LIFTING AND LUBRICATION DIAGRAMS

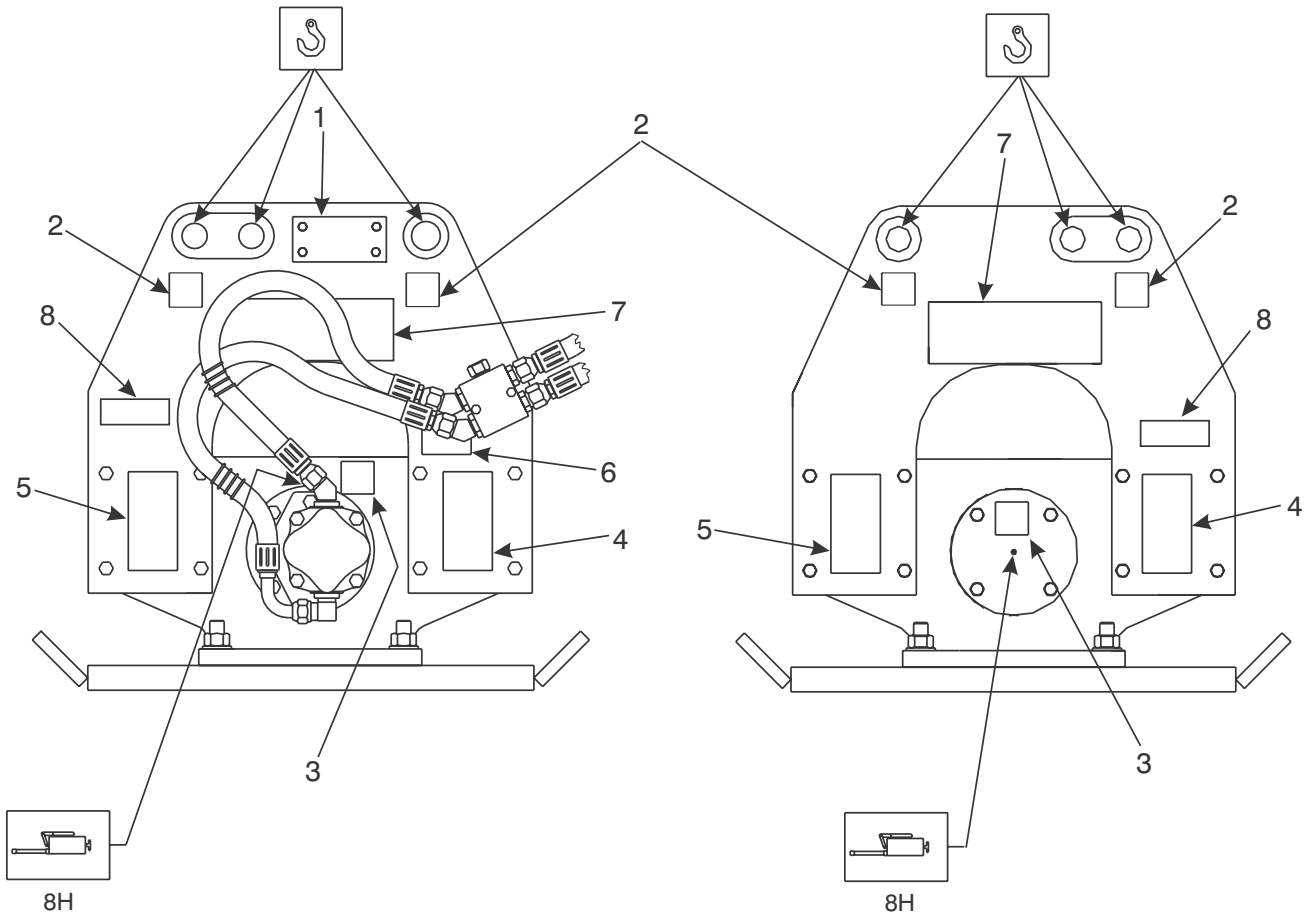

STD Ho-Pac Decal & Lubrication Drawing
(This Model has been discontinued.)

STD Ho-Pac (Discontinued)
Decal and Lubrication Parts List
Part No. 981201

ITEM ONLY	QTY.	PART NO.	DESCRIPTION
1	1	676980	ID Plate
2	4	676982	Lift Point
3	2	676985	Grease 8 hr.
4	2	676981	Stay Clear
5	2	676984	Read Instructions
6	1	676983	Hot Surface
7	2	676653	Allied Logo
8	2	100155	Decal - Model 8700C
9	1	818676	Pressure I.D. Tag (Located on Pressure Hose)

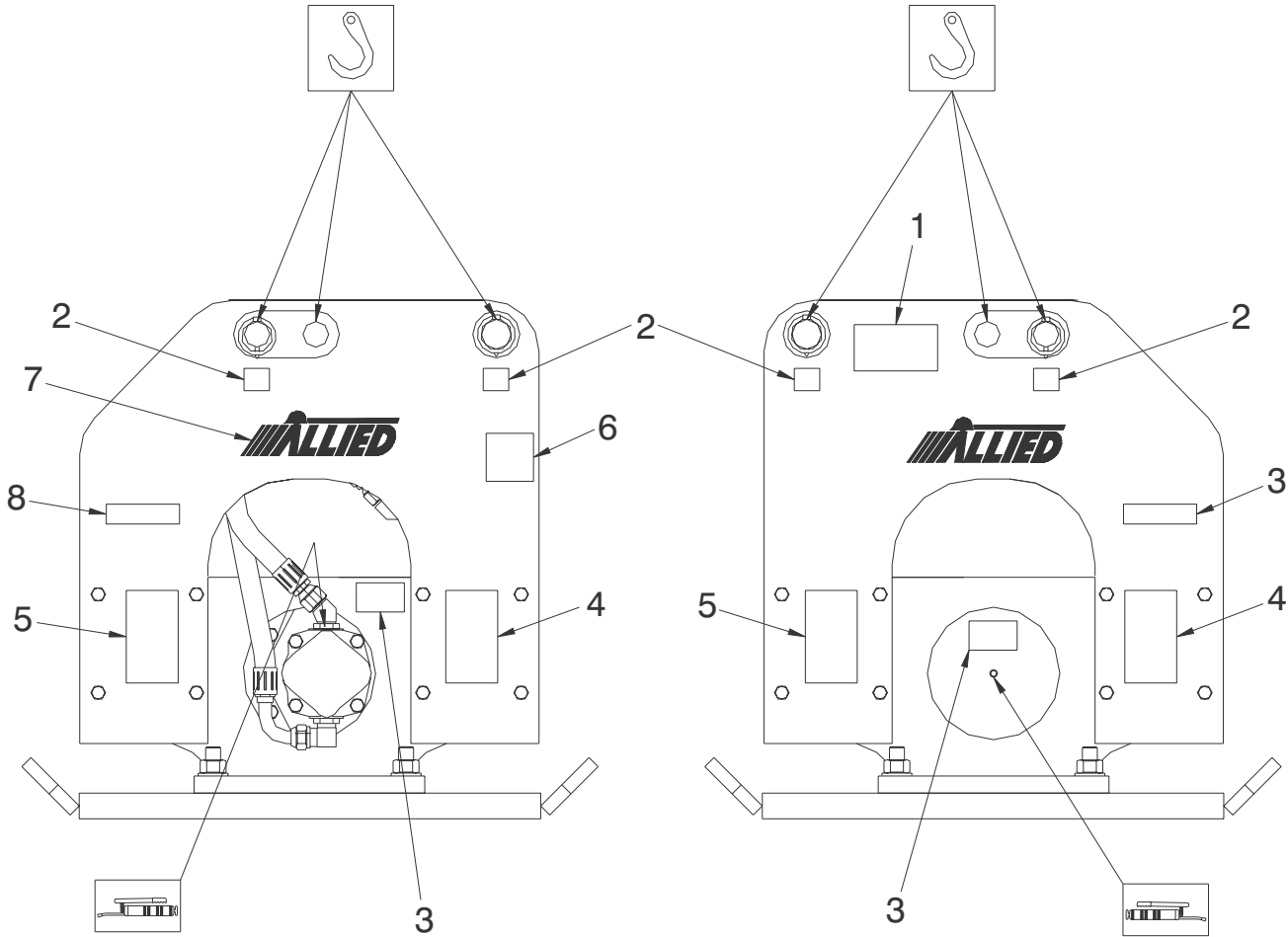

BSF Ho-Pac Decal & Lubrication Drawing

BSF Ho-Pac
Decal and Lubrication Parts List
Part No. 981201

ITEM ONLY	QTY.	PART NO.	DESCRIPTION
1	1	676980	ID Plate
2	4	676982	Lift Point
3	2	676985	Grease 8 hr.
4	2	676981	Stay Clear
5	2	676984	Read Instructions
6	1	676983	Hot Surface
7	2	676653	Allied Logo
8	2	100155	Decal - Model 8700C
9	1	818676	Pressure I.D. Tag (Located on Pressure Hose)

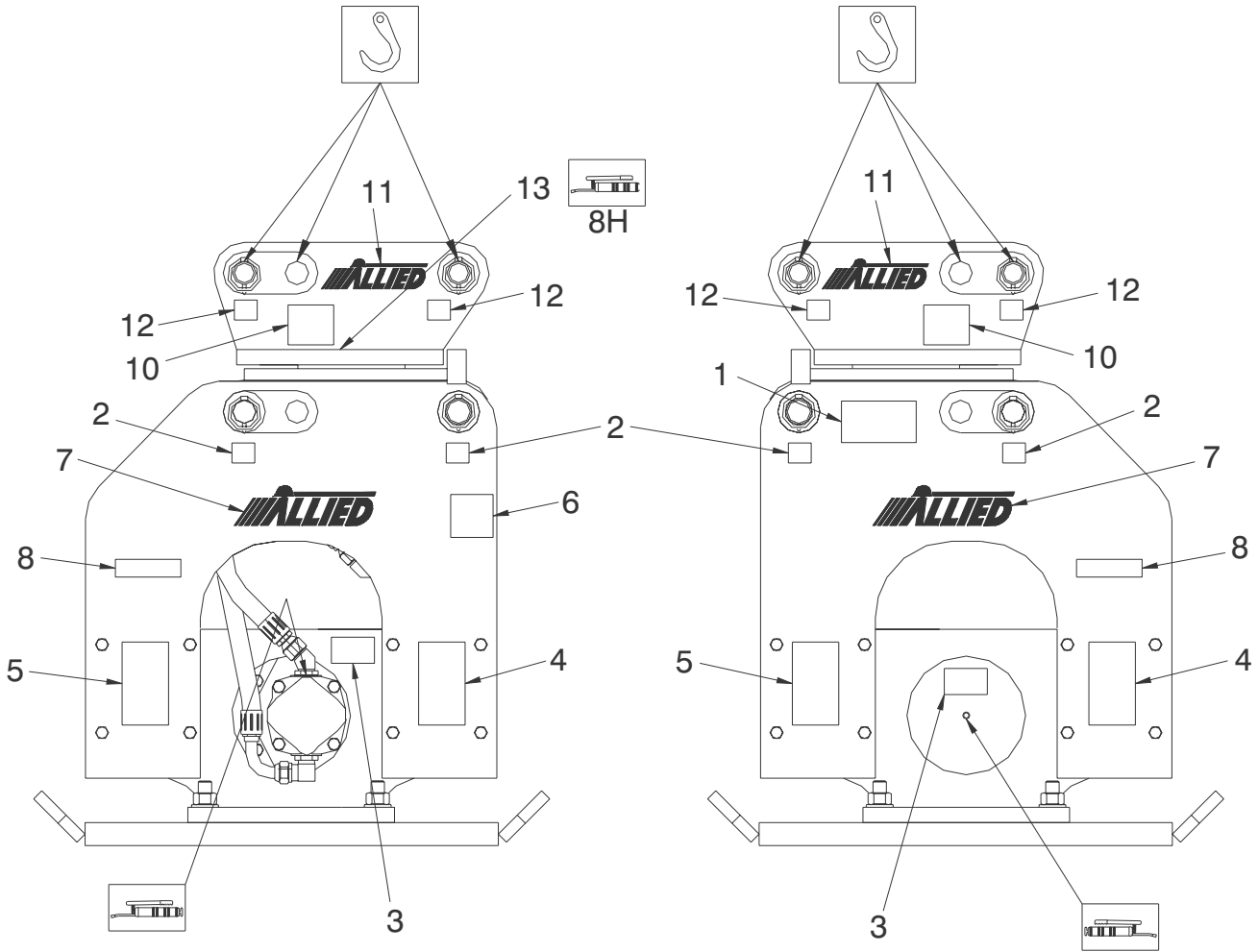

BSF Ho-Pac with Swivel Decal & Lubrication Drawing

BSF Ho-Pac with Swivel Decal and Lubrication Parts List			
ITEM ONLY	QTY.	PART NO.	DESCRIPTION
		981201	Ho-Pac Decals
1	1	676980	ID Plate
2	8	676982	Lift Point
3	3	676985	Grease 8 hr.
4	2	676981	Stay Clear
5	2	676984	Read Instructions
6	1	676983	Hot Surface
7	2	676653	Allied Logo
8	2	100155	Decal - Model 8700C
9	1	818676	Pressure I.D. Tag (Located on Pressure Hose)
		676957	Swivel Decals
10	2	815696	Made in USA
11	2	676651	Decal - Allied
12	4	676982	Lift Point
13	1	676985	Grease 8 hr.

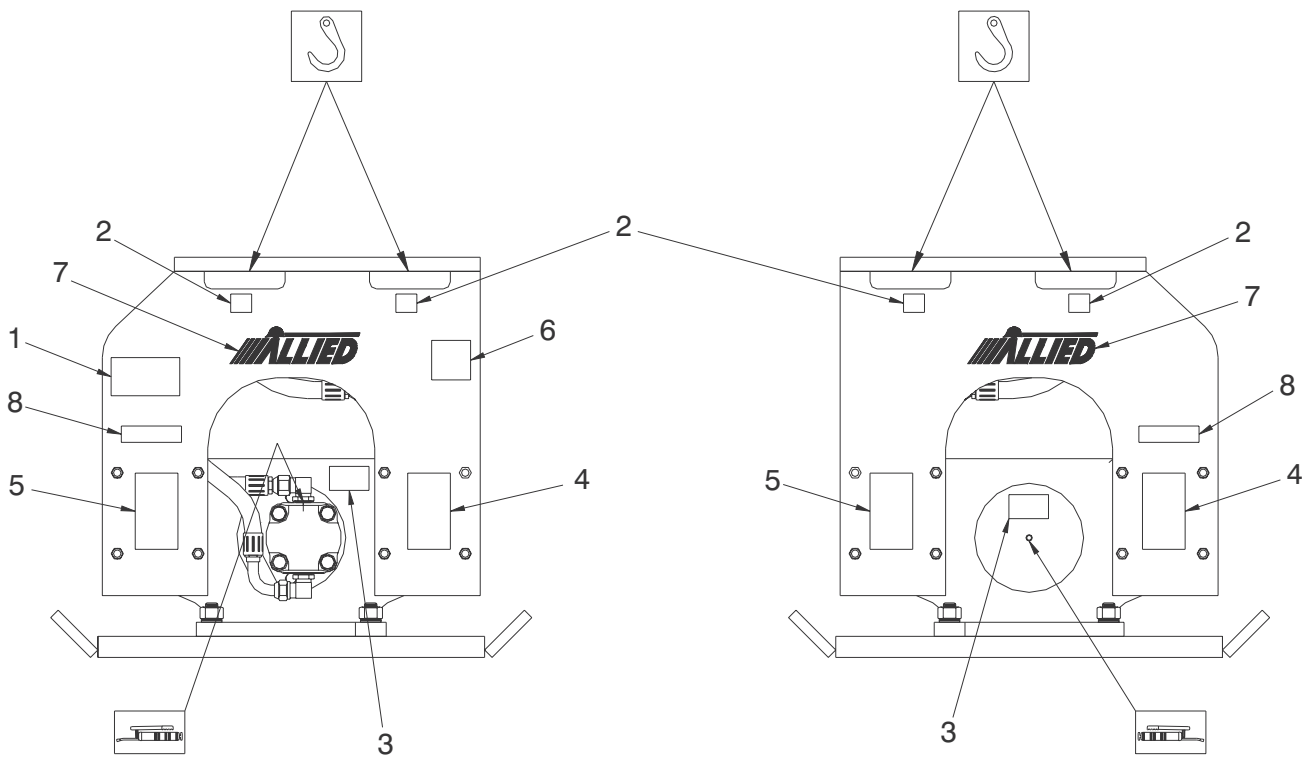

Custom Flat Top Ho-Pac Decal & Lubrication Drawing

Custom Flat Top Ho-Pac
Decal and Lubrication Parts List
Part No. 981201

ITEM ONLY	QTY.	PART NO.	DESCRIPTION
1	1	676980	ID Plate
2	4	676982	Lift Point
3	2	676985	Grease 8 hr.
4	2	676981	Stay Clear
5	2	676984	Read Instructions
6	1	676983	Hot Surface
7	2	676653	Allied Logo
8	2	100155	Decal - Model 8700C
9	1	818676	Pressure I.D. Tag (Located on Pressure Hose)

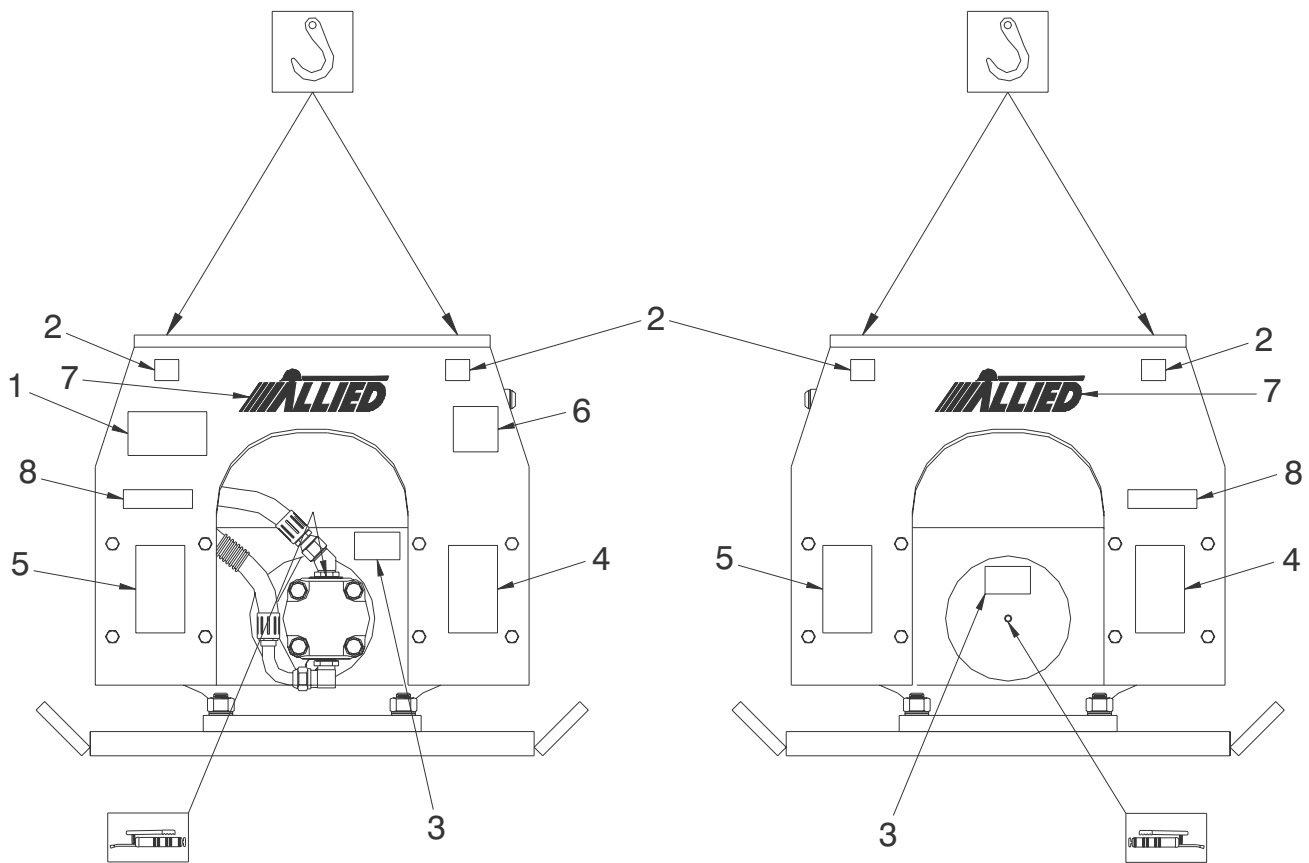

SCS Flat Top Ho-Pac Decal & Lubrication Drawing

SCS Ho-Pac
Decal and Lubrication Parts List
Part No. 981201

ITEM ONLY	QTY.	PART NO.	DESCRIPTION
1	1	676980	ID Plate
2	4	676982	Lift Point
3	2	676985	Grease 8 hr.
4	2	676981	Stay Clear
5	2	676984	Read Instructions
6	1	676983	Hot Surface
7	2	676653	Allied Logo
8	2	100155	Decal - Model 8700C
9	1	818676	Pressure I.D. Tag (Located on Pressure Hose)

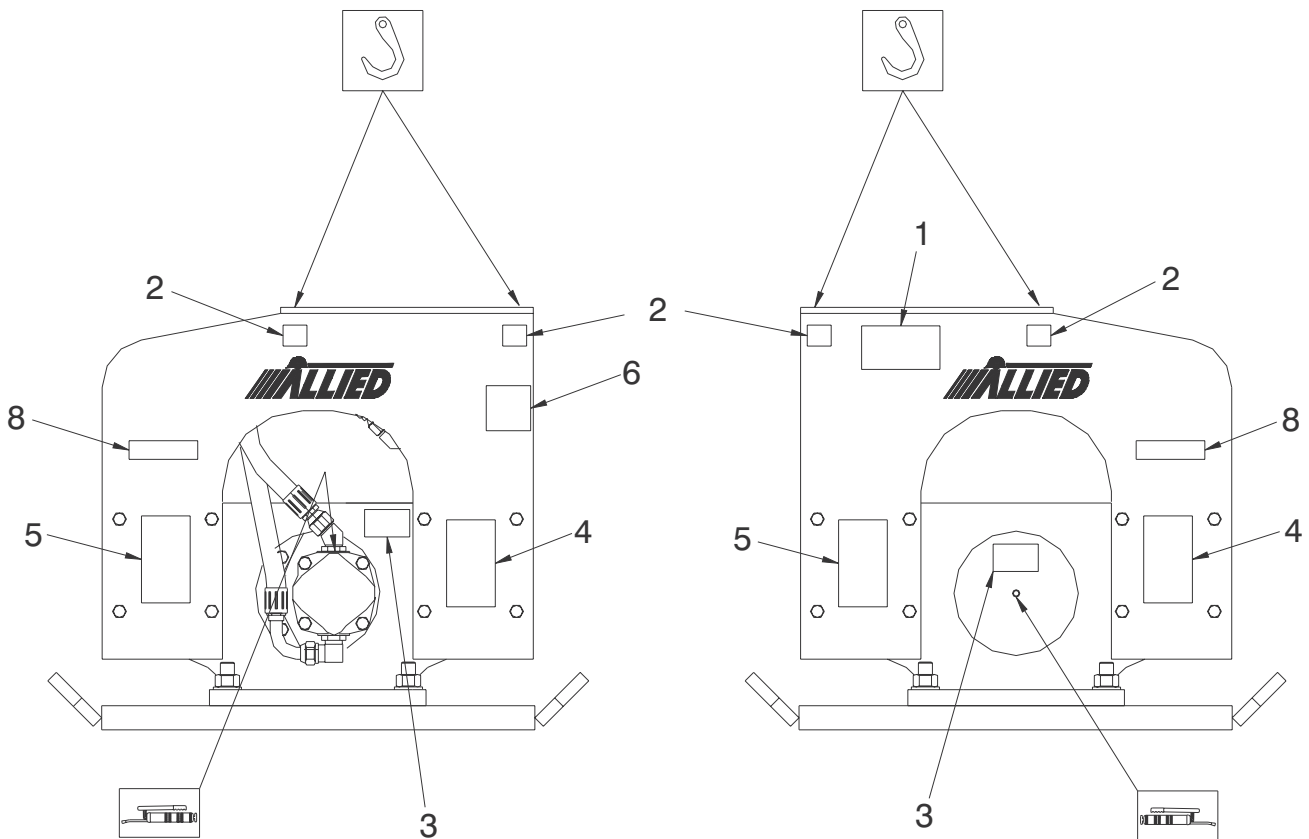

BCS Flat Top Ho-Pac Decal & Lubrication Drawing

BCS Ho-Pac
Decal and Lubrication Parts List
Part No. 981201

ITEM ONLY	QTY.	PART NO.	DESCRIPTION
1	1	676980	ID Plate
2	4	676982	Lift Point
3	2	676985	Grease 8 hr.
4	2	676981	Stay Clear
5	2	676984	Read Instructions
6	1	676983	Hot Surface
7	2	676653	Allied Logo
8	2	100155	Decal - Model 8700C
9	1	818676	Pressure I.D. Tag (Located on Pressure Hose)

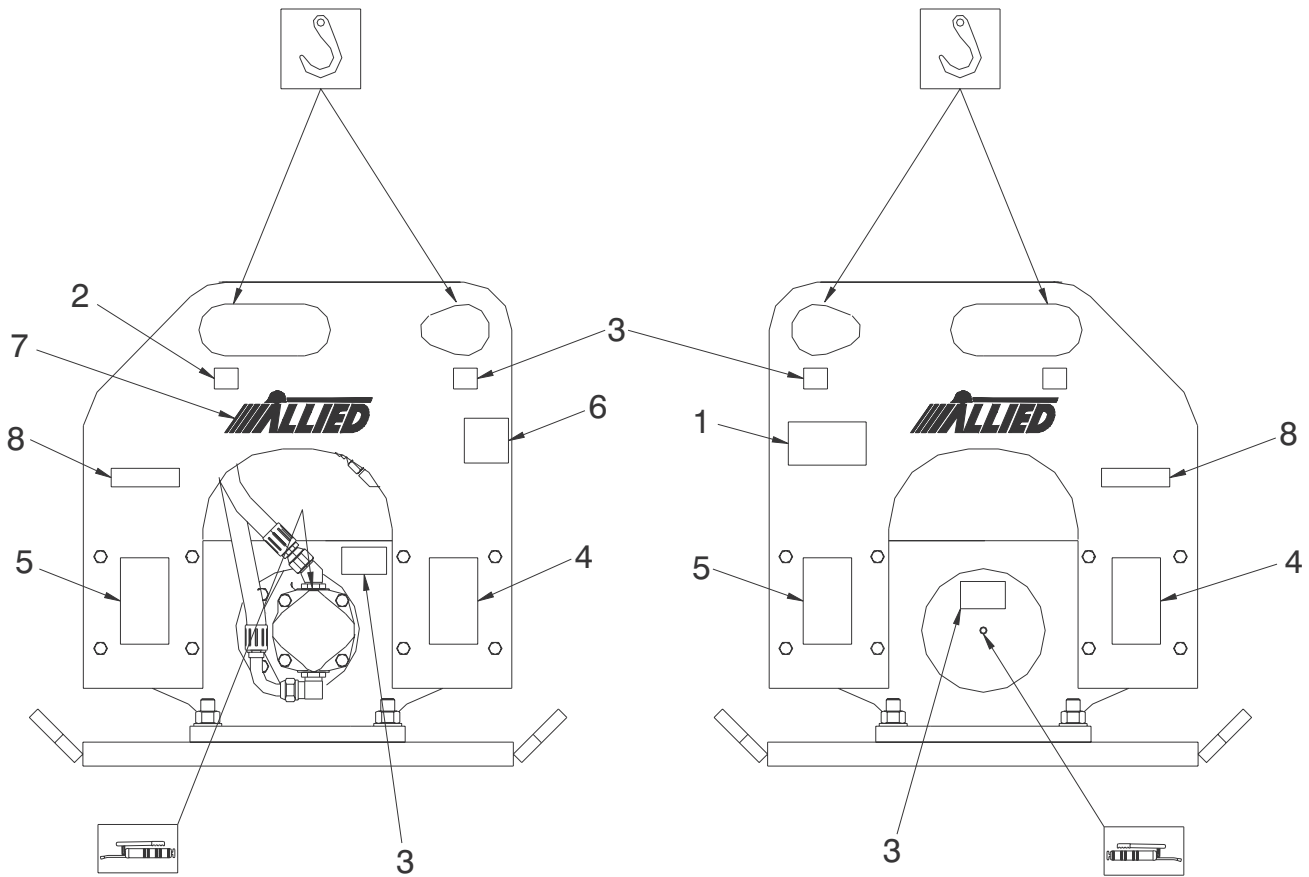

VMS V10 Ho-Pac Decal & Lubrication Drawing

VMS V10 Ho-Pac
Decal and Lubrication Parts List
Part No. 981201

ITEM ONLY	QTY.	PART NO.	DESCRIPTION
1	1	676980	ID Plate
2	4	676982	Lift Point
3	2	676985	Grease 8 hr.
4	2	676981	Stay Clear
5	2	676984	Read Instructions
6	1	676983	Hot Surface
7	2	676653	Allied Logo
8	2	100155	Decal - Model 8700C
9	1	818676	Pressure I.D. Tag (Located on Pressure Hose)

SECTION 5.0 MOUNTING INFORMATION

5.1 VMS Mounting

The VMS mounting kit contains two collars, two plugs, and two pins as shown in the diagram below. The combination of the VMS design frame and a VMS mounting kit provides unequalled versatility and ease in attaching the units to carriers, and in transferring a Ho-Pac from one carrier to another. Also, Ho-Pacs can be quickly adapted to different quick couplers.

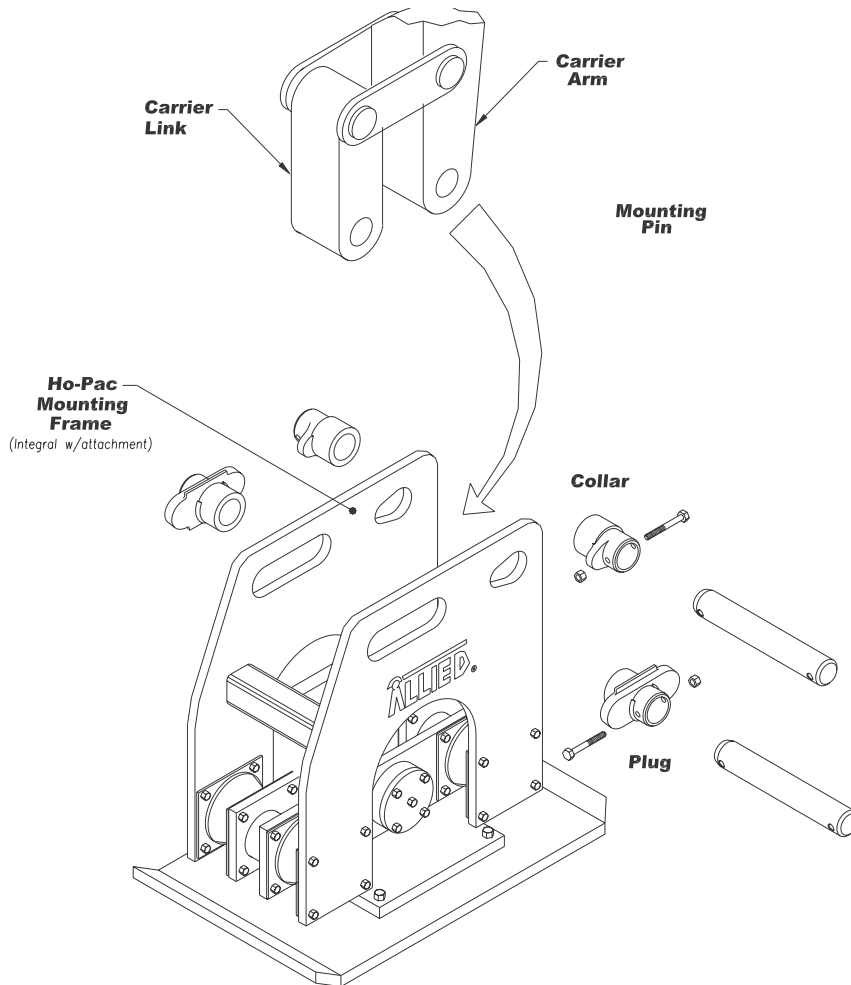

VMS Mounting

5.2 BCS and SCS Mounting

The flat top Ho-Pac can be mounted on a specific carrier with an adaptor bracket that is bolted to the Ho-Pac top plate as shown below. Brackets are available for each mounting type and can be custom designed when required. Each mounting kit contains the mounting bracket, fastener kit, pins; and bushings, spacers, sleeve bushings and miscellaneous hardware as required. The mounting hardware varies by application and is configured by Allied based on carrier specifications. The illustration shown below is a typical bracket; brackets vary with the specific application.

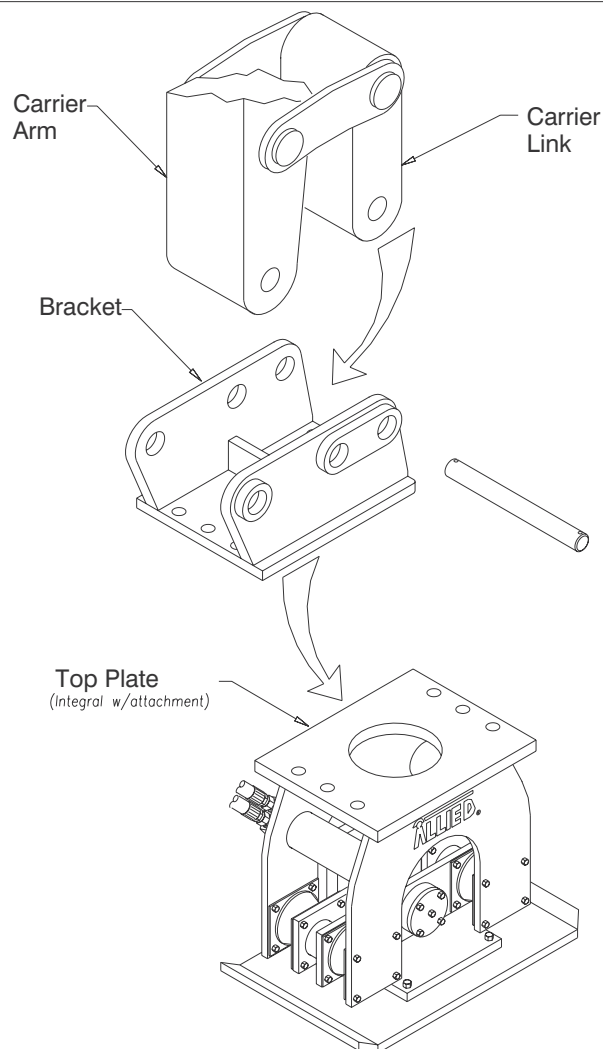

BCS and SCS Mounting

5.3 BSF Pin-On Mounting

The BSF mounting has the following dimensions:

Stick Pin	1.75 Dia
Link Pin	1.50 Dia
Bracket Width	10.25
Pin CTC Distance	10.50 & 14.00

A BSF Mounting Kit is supplied with one of the configurations shown below, to adapt the standard Ho-Pac pin diameters and bracket width to fit a specific carrier. In configurations #2, 3, 4, 5 & 6 below, the kit includes bushings that fit into the carrier stick and link so that mounting pins smaller than the carrier OEM pins can be used. These smaller mounting pins are included in the kit.

5.4 Swivel Mount

The swivel mount provides versatility in placing the Ho-Pac in operating position. The Ho-Pac can be turned or “swiveled” to operate at either a 45° or a 90° angle to the boom. This is especially good for compaction in trenches, or whenever the area of operation is not in line with the stick. The bottom of the swivel mount attaches to the Ho-Pac frame with mounting pins and related hardware or to the flat top with a fastener kit. The top of the swivel mount is attached to the carrier.

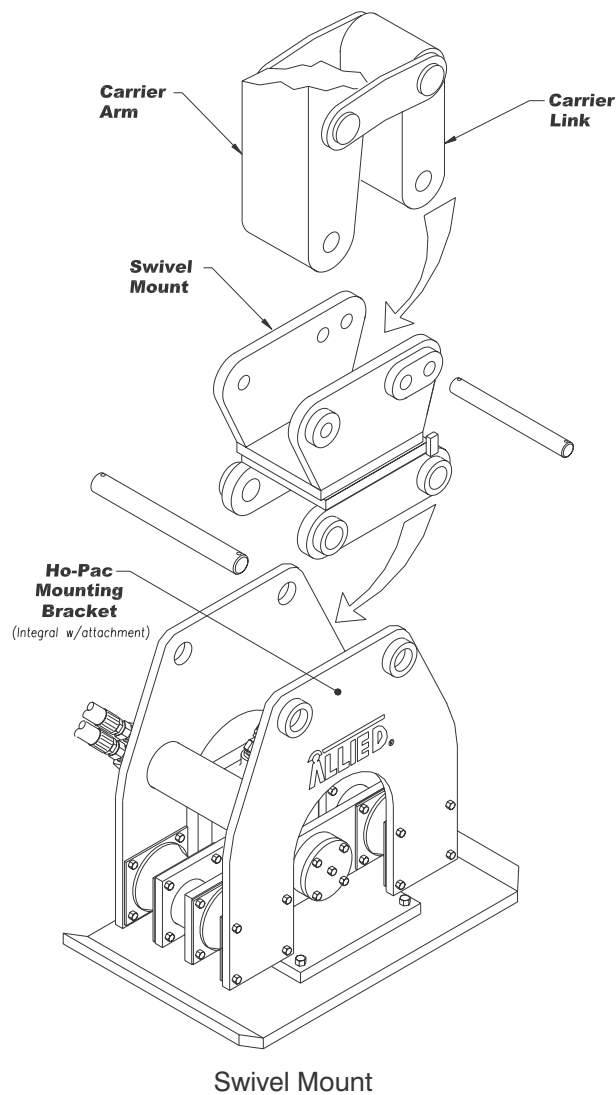

SECTION 6.0 GENERAL CONSTRUCTION SAFETY

6.1 Owner's Responsibilities

The equipment owner shall:

- Provide this technical manual to the Ho-Pac operators.
- Train all operating personnel and enforce the procedures explained in this manual, especially regarding safety to personnel and equipment.
- Adapt these general instructions to specific applications.

6.2 General Construction Safety

Follow standard safety precautions expected and required of those working in construction, including but not limited to: locating existing underground service and utility lines, establishing pedestrian barriers and using personnel protection equipment, etc.

6.3 Federal, State, Local and OSHA Construction Guidelines and Regulations

Use the Ho-Pac in accordance with all federal, state and local regulations regarding construction practices and public safety. Identification of, and compliance to, governing regulations are the responsibility of the owner and operator.

In the United States, comply with the recommendations of the Occupational Safety and Health Administration standards of the U.S. Department of Labor. For OSHA construction guidelines contact your local federal government office or write:

U.S. Government Printing Office
Superintendent of Documents
P.O. Box 371954
Pittsburgh, Pa. 15250

Ask for Construction Industry OSHA Standards Stock #869-034-00107-6.

6.4 General Safety Summary

The safe and effective use of any heavy construction equipment depends upon proper installation, operation, maintenance and repair. Operational safety must encompass all of these factors. This Section includes minimum safety policies the Ho-Pac owner shall establish for all Ho-Pac installations. The operational safety program must be tailored by the Ho-Pac owner to the specific site and application. Such a program will result in increased equipment life and performance and reduced downtime. Most importantly, it will reduce the risk of equipment damage and personnel injuries.

6.4.1 CAUTIONS and WARNINGS

Throughout this manual detailed CAUTIONS and WARNINGS are included with instructions and procedures. Even experienced service technicians are to review these CAUTIONS and WARNINGS prior to performing a procedure. CAUTIONS and WARNINGS are highlighted by the symbol shown here and explained as follows:



 **WARNING** 

Instructions preceded by this symbol identify hazards to personnel. WARNING instructions must be followed to ensure safe handling and operation. These instructions shall be followed at all times. Improper operation or servicing can result in personal injury. Read this manual thoroughly before operating or maintaining the Ho-Pac.

 **CAUTION** 

Instructions identified with this symbol are important to prevent damage to equipment and to maintain full service life of the Ho-Pac. Follow them carefully. Operation or service not in accordance with these instructions may subject the Ho-Pac to conditions beyond its design capability. Read this manual thoroughly before operating or maintaining the Ho-Pac.

6.4.2 Personnel Precautions

- Always wear safety glasses, and protective clothing when operating or handling the Ho-Pac.
- All personnel in the immediate area must wear ear protection.

SECTION 7.0 CARRIER APPLICATION

The Allied 8700C Ho-Pac is designed for use and installation on medium to large rubber tire backhoe loaders and small excavators. The carrier must have adequate lift and hydraulic capacities to properly and safely operate the Ho-Pac. Refer to Section 4.1 Specifications for carrier weights.

An Allied installation kit is recommended to properly install the Ho-Pac. Allied installation kits are specifically designed for each carrier. Each kit contains the proper mechanical and hydraulic components for optimum Ho-Pac performance.

Allied hydraulic kits utilize the Allied “AC” series valves. The “AC” series solenoid-operated valve provides regulated, priority flow at a controlled pressure.

Always follow hydraulic kit installation instructions. Carrier hydraulic circuit designs differ and damage to the Ho-Pac or carrier may result if the hydraulic kit is improperly installed. Contact Allied for installation recommendations.

While the Ho-Pac is designed to minimize the vibrations induced into the carrier, the operator must be isolated from excessive vibrations should they occur. Refer to the carrier’s manual for specific information regarding vibration isolation of the operator’s compartment or seat.

SECTION 8.0 INSTALLATION & REMOVAL

8.1 Installation



WARNING

Always wear gloves and eye protection when connecting hydraulic connections, and installing mounting pins and hardware.



CAUTION

Mount only on carriers with adequate lift and hydraulic capacity. Under no circumstances shall the oil pressure supplied to the Ho-Pac exceed recommended maximums. (Section 4.0)



CAUTION

The Ho-pac hydraulic return line must be open to tank. Hydraulic motor damage results if the return line is suddenly closed by incorrect hydraulic circuitry.

1. Prior to installation, carefully inspect:
 - a. Spring mounts for cracks and other damage.
 - b. Hoses and fittings for damage.
 - c. Threaded fasteners, boom pins, and mounting hardware for damage.
2. Repair or replace any damaged components.

3. Follow hydraulic and mounting kit installation instructions.



WARNING

Keep hands and fingers clear of mounting pin holes, carrier linkage and other pinch points while equipment is being positioned.



CAUTION

During installation, instruct carrier operator to operate carrier controls only as instructed by Ho-Pac installer.



CAUTION

Never install hydraulic hoses inside the operators cab.

4. After installation and prior to use, briefly operate the Ho-Pac, then stop the Ho-Pac and re-check the following:
 - a. Hydraulics hoses and fittings for leaks.
 - b. Mounting hardware for loose or missing parts.
 - c. Bolt torques. See Section 10.3.

8.2 Removal



Always wear gloves and eye protection when disconnecting hydraulic connections, and removing mounting pins and hardware.



Do not disconnect hydraulics if hoses are pressurized.



Hoses, hydraulic motor and hydraulic fittings may be hot after operation.



Keep hands and fingers clear of mounting pin holes, carrier linkage and other pinch points while equipment is positioned.





During removal, instruct carrier operator to operate carrier controls only as instructed by Ho-Pac installer.

1. Position Ho-Pac safely on the ground.
2. Remove hydraulic connections.
3. Be sure unit is stable prior to removing mounting hardware.
4. Remove mounting hardware.
5. Reinstall mounting hardware on Ho-Pac to avoid loss or damage.

**SECTION 9.0
OPERATION**



The Ho-Pac is designed to operate with the carrier over a wide range of temperatures. Refer to the carrier’s recommendations for operating temperature range.

 **CAUTION** 

At temperatures below 32° F (0°C), operate the Ho-Pac for a few minutes without down force to allow the spring mounts to warm.

 **WARNING** 



Wear ear protection as required by federal and local regulations.

 **CAUTION** 

Do not operate the Ho-Pac underwater. Bearing damage may result.



1. Daily before operating, carefully inspect:
 - a. Spring mounts for cracks and other damage.
 - b. Hoses and fittings for leaks and other damage.
 - c. Threaded fasteners, boom pins, and mounting hardware for damage.
2. Repair or replace any damaged components prior to operation.

3. Daily, lubricate bearings. See Section 10.2.
4. Prior to compaction, the excavation shall be back-filled using other equipment.



 **CAUTION** 

Do not use the Ho-Pac to move materials. Ho-Pac damage may result.

5. Position carrier in-line with direction of work.
6. Position the Ho-Pac base plate parallel to the work surface and within view of the operator. The base plate must be in full contact with the work surface for maximum effectiveness.

 **CAUTION** 

Do not operate the Ho-Pac without base plate. A dynamic imbalance and equipment damage may result.

 **WARNING** 

Never activate the Ho-Pac unless the operator is seated in the operator’s seat and in full control of the machine. Refer to carrier’s instructions.

7. Activate the Ho-Pac with the switch located in the operator’s cab.



Keep personnel away from the Ho-Pac while in operation. Never operate the Ho-Pac with workers in close proximity to the Ho-Pac.

8. Apply down force with the carrier boom to stretch spring mounts approximately 1 inch (25 mm).



Do not allow mounting frame to contact base plate. Spring mount and frame damage can result.



Ground vibrations may collapse trench walls. Stand clear.

9. As the material compacts, maintain a constant down force with the carrier. For larger areas, a repetitive, back and forth sweeping motion is effective. The initial pass is continued until compaction is no longer apparent, typically 10 to 15 seconds.

10. It may be necessary to adjust the idle speed of the carrier to maintain proper Ho-Pac flow requirements.



Do not operate Ho-Pac with hydraulic oil temperature above 180° F (82°C).

11. It may be necessary to try different lift heights to determine the most effective lift to achieve the desired level of compaction. Compacted densities are reduced at the bottom of excessively high lifts.
12. After compaction is complete, re-position the Ho-Pac and/or carrier to continue working. It is not necessary to stop the Ho-Pac for minor carrier boom re-positioning.



Operation of this equipment requires the operator's full attention.

13. Repeat compacted lifts as necessary to achieve finished grade.

SECTION 10.0 TROUBLESHOOTING

Listed below are several operating problems and their recommended corrective action.

1. Unit does not run:
 - a. Insufficient oil pressure or flow. Check hydraulic supply system. Correct as required.
 - b. Failed bearings. Inspect and replace bearings.
 - c. Broken motor shaft or worn splines. Inspect and replace worn parts.
2. Unit runs erratically:
 - a. Erratic oil pressure or flow. Check hydraulic supply system. Correct as required.
 - b. Failed spring mount. Inspect and replace failed mount.
3. Unit runs with excessive noise or vibration:
 - a. Failed bearing. Inspect and replace bearings.
 - b. Loose bolts or mounting hardware. Inspect and tighten bolts.
4. Unit runs, but stalls under load:
 - a. Pressure relief too low. Check hydraulic supply system. Correct as required.
 - b. Failed bearing. Inspect and replace bearings.
 - c. Motor worn or motor seals failed. Inspect and replace motor.

For conditions other than these, contact the Allied Technical Service Department.

SECTION 11.0 SERVICE AND MAINTENANCE

11.1 General Guidelines

Use standard mechanic's techniques and tools to disassemble and assemble the Ho-Pac.



WARNING

Follow all safety practices and wear appropriate protective equipment.

Use only genuine Allied replacement parts. Failure to use approved replacement parts may subject the operator to injury and the Ho-Pac to premature failure. The use of unapproved replacement parts voids the warranty.

Do not make any alterations to the Ho-Pac without written authorization from the Allied Engineering Department.



WARNING

Ho-Pac components are heavy. Use proper lifting and support equipment.



WARNING

Service the Ho-Pac in safe work areas. Never service the Ho-Pac on the carrier or in the trench.

Maintain clean oil. Follow the carrier manufacturer's recommendations for hydraulic oil grade and hydraulic system maintenance.

Clean and properly dispose of any spilled oil as required by governing regulations.

Contact the Allied Technical Service Department with questions regarding maintenance, operation or replacement parts.



WARNING

Never lubricate the Ho-Pac while it is operating.

11.2 Daily Maintenance

Clean and lubricate bearings daily or after 8 hours of operation. Refer to Section 11.5.

Clean and oil Ho-Pac.

11.3 Preventive Maintenance

After every 100 hours of operation, the Ho-Pac should be cleaned and inspected.

- Check all components for excessive wear.
- Check spring mounts for cracks and wear.
- Check all hardware for tightness. Refer to 11.6 for bolt torques.

The frequency of maintenance depends upon the operating environments and conditions of operation. Refer to 11.4 for additional maintenance considerations.

11.4 Conditional Maintenance

Clean and lubricate all Ho-Pac working surfaces under the following conditions:

- The Ho-Pac is operated in extremely humid weather conditions.

- The HoPac is operated in muddy or extremely wet soils.
- If reduced performance is observed.

11.5 Lubrication

The Allied Ho-Pac is simply lubricated through standard lubrication fittings. See lubrication diagram in Section 4.3

Under normal operating conditions, lubricate the bearings daily or after 8 hours of operation. During extreme operating conditions, such as high temperatures and dusty conditions, lubricate more frequently. The injection of grease into the bearings cavities not only provides lubrication, but also flushes impurities from the bearings to increase bearing life.

Recommended grease:

Use a premium quality, multipurpose, extreme pressure, petroleum based grease with lithium and anti-rust additives. Minimum oil viscosity shall be 14.5 cSt at 100° C.

Approved brands:

- Shell Oil -Alvania EP2
- Mobile Oil Co. - Mobilux EP2
- Texaco Inc. -RB2.

1. Position Ho-Pac for easy access to lubrication fittings.
2. Carefully clean lubrication fitting prior to use.
3. At each lubrication point, inject 5 “shots” with a standard manual grease gun.

After Ho-Pac rebuild or for completely dry bearings, inject 20 “shots” in each lubrication point with a standard manual grease gun.

11.6 Bolts

Because the Ho-Pac is a vibratory tool, it is extremely important that threaded fasteners are properly tightened. Always follow the torque specifications in this section.

 **CAUTION** 

Replace any damaged fasteners prior to Ho-Pac operation. Use only Allied replacement parts.

1. Clean threaded fasteners and surfaces to be bolted.
2. Apply a light coat of grease to threads and washer faces, except for base plate bolts.
3. For base plate bolts only, apply a commercial grade, thread adhesive. Follow manufacturer’s recommendations. (Example: Loctite 271 Thread Adhesive/Sealant)
4. Initially tighten the bolts to 10 ft-lbs (14 N-m).
5. Tighten the fasteners according to the table below.

<u>Diameter</u>	<u>Final Torque - Lubricated</u>
3/8 inch	35 ft-lbs (47 N-m)
1/2 inch	80 ft-lbs (108 N-m)
5/8 inch	170 ft-lbs (230 N-m)
7/8 inch	400 ft-lbs (542 N-m)
1 inch	650 ft-lbs (880 N-m)

6. After bolt installation, operate the Ho-Pac a few hours, then re-check bolt torques.

11.7 Bearing Failure & Replacement

Because of the high loads and rotational speeds, bearing failure is usually sudden. A scraping or rattling sound is an indication of imminent bearing failure. Visually inspect the bearings for broken or damaged components to determine if replacement is necessary.

Bearing service shall be performed in a properly equipped workshop. Use of a manual arbor press is recommended. Do not attempt to replace bearings in the field.



CAUTION

Use only Allied replacement parts.

Removal:

1. Remove hydraulic hoses from motor.
2. Remove the cover plate, hydraulic motor and adapter plate.
3. Remove bearing housing assembly from the main housing. It is not necessary to remove eccentric from main housing.



WARNING

Be careful that eccentric shaft does not fall and injure hands or fingers.

4. Remove the bearing from the housing by pressing on the bearing inner race from the interior side of the bearing housing. Properly support the bearing housing in the press.
5. If the outer race remains in the housing, do not pry out. Carefully place a small bead of weld, 1/8 inch (3 mm) along the inside diameter of the outer race. After

the weld cools, the outer race can easily be removed.

Installation:

1. Thoroughly clean the bearing housing and eccentric shaft.
2. Pack the bearing with grease.
3. Slowly press the bearing into the housing. Apply contact pressure to the outer race only!
4. Install one bearing and housing onto the eccentric shaft.
5. Align in main housing.
6. Repeat with other bearing and housing.
7. Install cover plate, adapter plate and bolts.
8. Install hydraulic motor.



CAUTION

Follow bolt torque specifications. Refer to Section 11.3.

9. Install hydraulic hoses.
10. After completely assembled, follow installation and daily lubrication procedures.

11.8 Spring Mounts

The spring mounts are subject to aging and require periodic replacement. While mount life depends primarily on use, extreme environmental conditions and other factors can shorten mount life.

1. Position Ho-Pac on flat, stable surface.
2. Adequately support or block the mounting frame to relax mounts.



Do not place hands or fingers between Mounting Frame and Baseplate during removal of spring mounts or mount nuts.

3. Loosen all nuts prior to mount removal.
4. Remove mount nuts.
5. Remove mount.
6. Position new mount and re-install nuts.
See Section 10.3

If multiple mounts are to be replaced, it is recommended to completely replace one mount at a time.

11.9 Hydraulic Motor

There are no user-servicable parts in the hydraulic motor. Contact the Allied Technical Service Department for further information.

11.10 Warranty Protection

Maintain written records of Ho-Pac maintenance, service and repair. These records will be helpful if warranty coverage is ever in question. Each record shall include :

- The date of service, maintenance or repair.
- A description of the service, maintenance or repair performed. Include part numbers if applicable.
- Copies of purchase order(s) and invoice(s) for repair parts and service.
- The name and signature of the person performing the service, maintenance or repair.

SECTION 12.0 LIFTING & TRANSPORT

If the Ho-Pac is to be transported independent of the carrier;

1. Remove all loose debris from Ho-Pac.
2. If the swivel assembly is installed, lock swivel position with bolt.
3. Follow removal instructions in Section 7.2.
4. Secure hoses to unit to avoid accidental damage.
5. Lift Ho-Pac at approved lift points only with appropriate lifting equipment. See diagram in Section 4.3.



Do not lift Ho-Pac by the mounting pins. The Ho-Pac may shift and cause damage or personnel injury.

6. Adequately stabilize and secure Ho-Pac for transport.

If the Ho-Pac is transported while installed on the carrier:

1. Remove all loose debris from Ho-Pac.
2. If the swivel assembly is installed, lock swivel position with bolt.
3. Secure hoses to unit to avoid accidental damage.
4. Inspect the mounting pins and hardware for damage and integrity.
5. Transport carrier in accordance with carrier manufacturer's recommendations.

SECTION 13.0 STORAGE

Several simple precautions are necessary for storage of the Ho-Pac.

1. Protect hydraulic connections from damage and debris. Plug hoses if hydraulic quick disconnects are not used.
2. Secure hoses to unit to prevent accidental damage.
3. Protect spring mounts and hydraulic hoses from weather and direct sunlight to reduce aging effects.
4. Support the Mounting Frame with blocks to minimize permanent sag in spring mounts.
5. Keep the motor full of oil and lubricate bearings to protect internal components.
6. Avoid wet or damp conditions to minimize rust.
7. Store in upright position.

This page intentionally
left blank.

SECTION 14.0 PARTS INFORMATION

NOTE

The following illustrations and parts lists are typical models of the 8700C Ho-Pac. Specific assemblies and mounting configurations may vary.

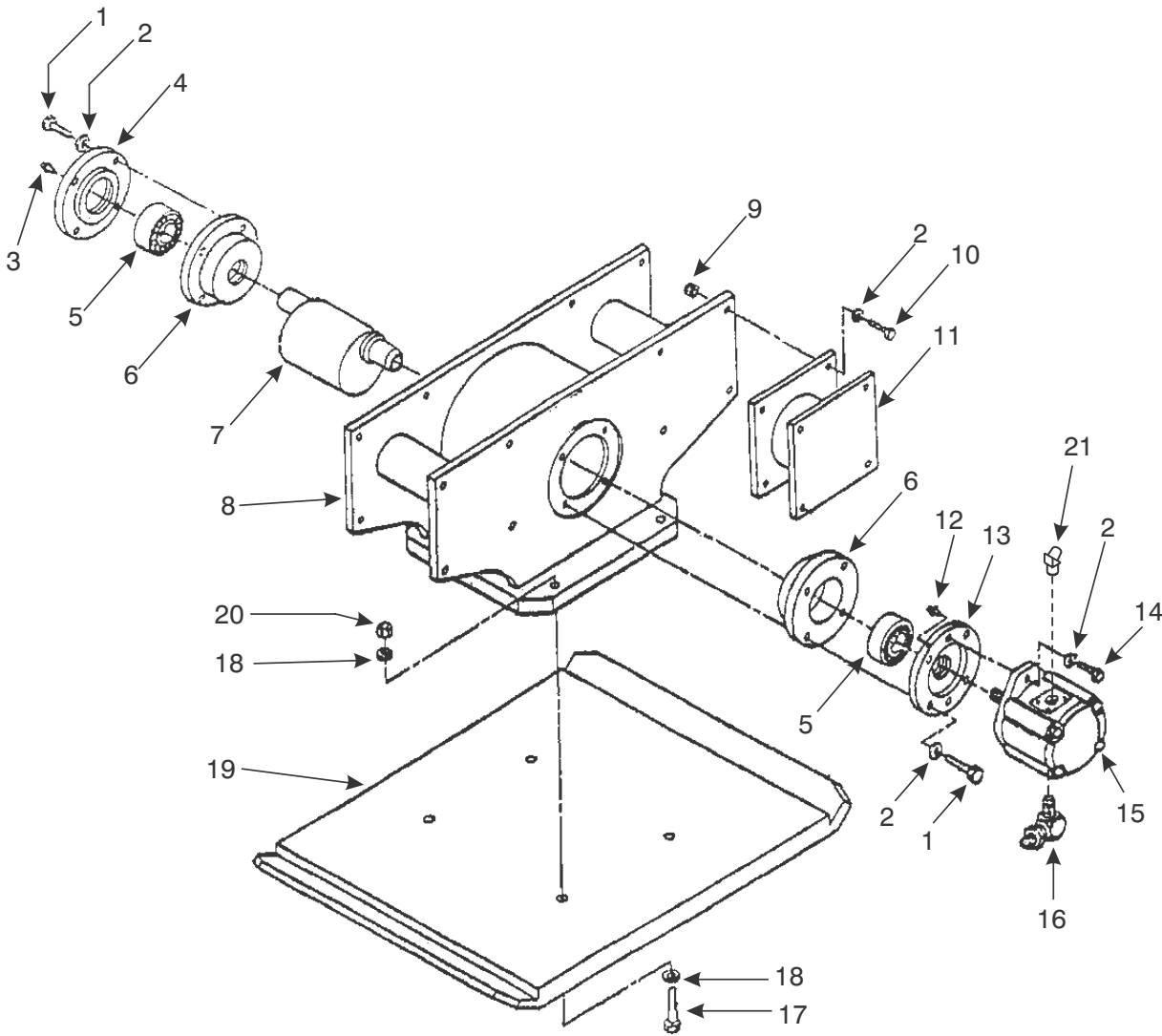

Dynamic Assembly & Suspension System

Dynamic Assembly & Suspension System Part No. 708800			
ITEM ONLY	QTY.	PART NO.	DESCRIPTION
1	8	708511	Hex Head Cap Screw
2	42	708512	Flat Washer
3	1	798197	Lubrication Nipple
4	1	708510	Cover Plate
5	2	708507	Roller Bearing
6	2	708508	Bearing Housing
7	1	708707	Eccentric
8	1	708782	Eccentric Housing
9	32	708787	Torque Nut
10	32	719730	Hex Head Cap Screw
11	4	719749	Rubber Spring Mount
12	1	708717	90° Lubrication Nipple
13	1	708779	Adapter Plate
14	2	708791	Hex Head Cap Screw
15	1	708777	Hydraulic Motor (S/N 8849 & Below)
	1	Optional	Hydraulic Motor (S/N 8850 & Above) Refer to Table 14.1, Motor & Valve Pkg.
*16	1	656531	90° Elbow
17	4	708516	Hex Head Cap Screw
18	8	719003	Flat Washer
19	1	708781	Compaction Plate
20	4	719004	Hex Nut
*21	1	817521	45° Elbow

* S/N 8849 & Below: Included in assembly 708800

S/N 8850 & Above: Included in assembly 708561, 708563, 676752, 101460, 101553

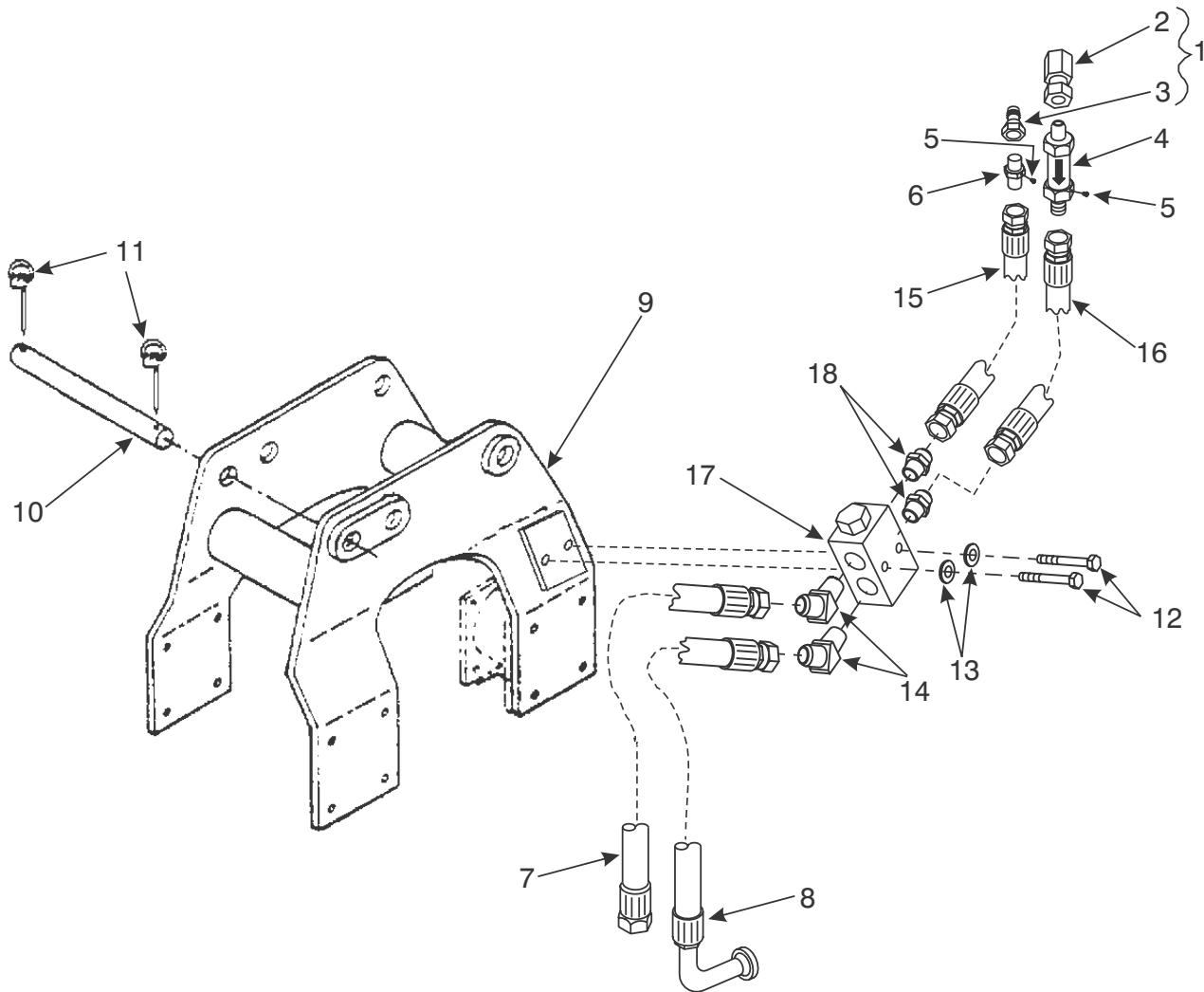

STD Ho-Pac Mounting Frame
(This Model has been discontinued.)

STD Ho-Pac Mounting Frame (Discontinued) Part No. 708780			
ITEM ONLY	QTY.	PART NO.	DESCRIPTION
1	1	670006	Q.D. Coupler Set (Includes Items 2 & 3)
2	1	670007	Q.D. Female Coupling
3	1	670008	Standard Q.D. Male Coupling
4	1	670270	Check Valve
5	2	667566	Hex Head Pipe Plug
6	1	708726	Adapter w/Port
7	1	676719	Hose Assembly (Return)
8	1	903994	Hose Assembly (Pressure)
9	1	708784	Mounting Frame
10	2	617080	Boom Pin
11	4	617104	Klik Pin
12	2	870368	Hex Head Cap Screw
13	2	865384	Flat Washer
14	2	817521	45° Elbow
15	1	678931	Hose Assembly
16	1	678930	Hose Assembly
17	1	676721	X-Line Check Valve
18	2	656723	Adapter

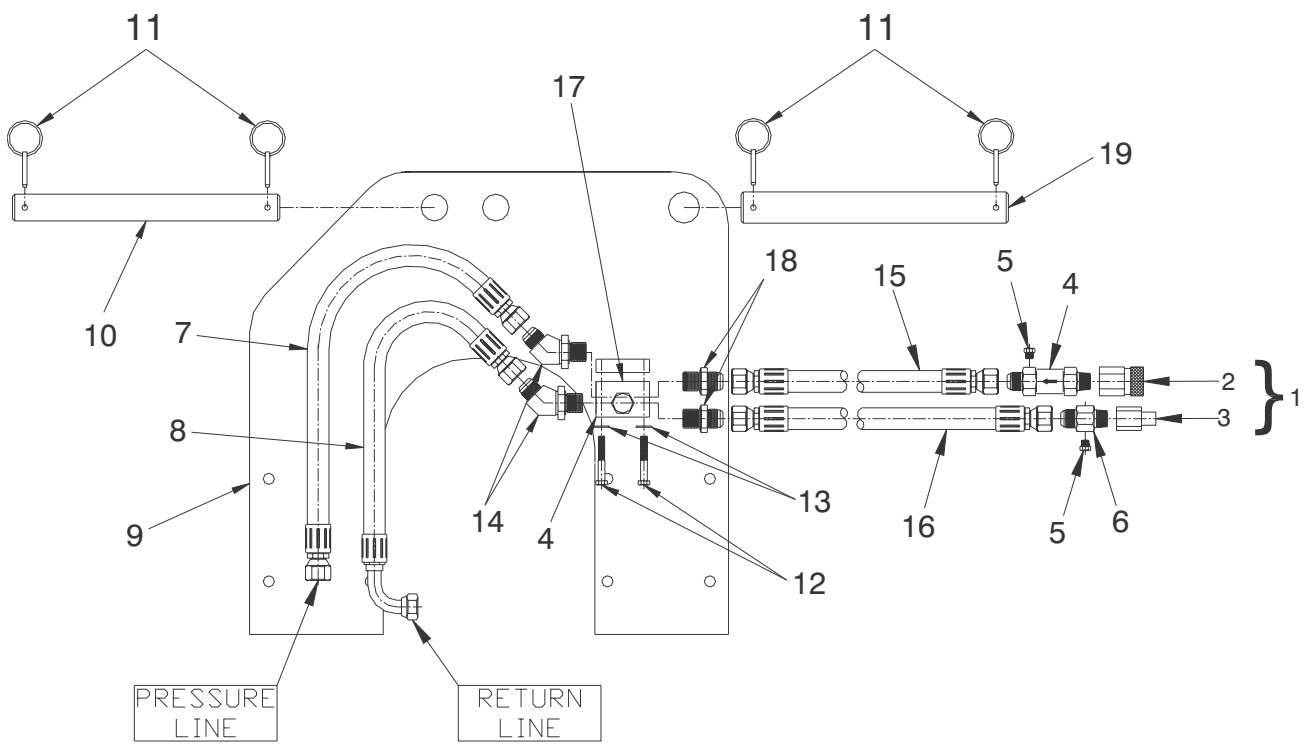

BSF Ho-Pac Mounting Frame

BSF Ho-Pac Mounting Frame Part No. 708561			
ITEM ONLY	QTY.	PART NO.	DESCRIPTION
1	1	670006	Q.D. Coupler Set (Includes Items 2 & 3)
2	1	670007	Q.D. Female Coupling
3	1	670008	Standard Q.D. Male Coupling
4	1	670270	Check Valve (S/N 8849 & Below)
5	2	667566	Hex Head Pipe Plug (S/N 8849 & Below)
6	1	708726	Adapter w/Port (S/N 8849 & Below)
7	1	101824	Hose Assembly (Pressure)
8	1	101823	Hose Assembly (Return)
9	1	708558	Mounting Frame
10	1	617080	Pin, 1.5 dia.
11	4	617104	Klik Pin
12	2	870368	Hex Head Cap Screw (S/N 8849 & Below)
	2	814213	Hex Head Cap Screw (S/N 8850 & Above)
13	2	865384	Flat Washer (S/N 8849 & Below)
	2	653339	Flat Washer (S/N 8850 & Above)
14	2	817521	45° Elbow
15	1	678931	Hose Assembly (Pressure)(S/N 8849 & Below)
	1	102865	Hose Assembly (Pressure)(S/N 8850 & Above)
16	1	678930	Hose Assembly (Return) (S/N 8849 & Below)
	1	102865	Hose Assembly (Return) (S/N 8850 & Above)
17	1	676721	X-Line Check Valve (S/N 8849 & Below)
	1	Optional	Valve (S/N 8850 & Above) Refer to Table 14.1 Motor & Valve Pkgs.
18	2	656723	Adapter (S/N 8849 & Below)
	2	817521	45° Elbow (S/N 8850 & Above)
19	1	653378	Boom Pin, 1.75 dia.

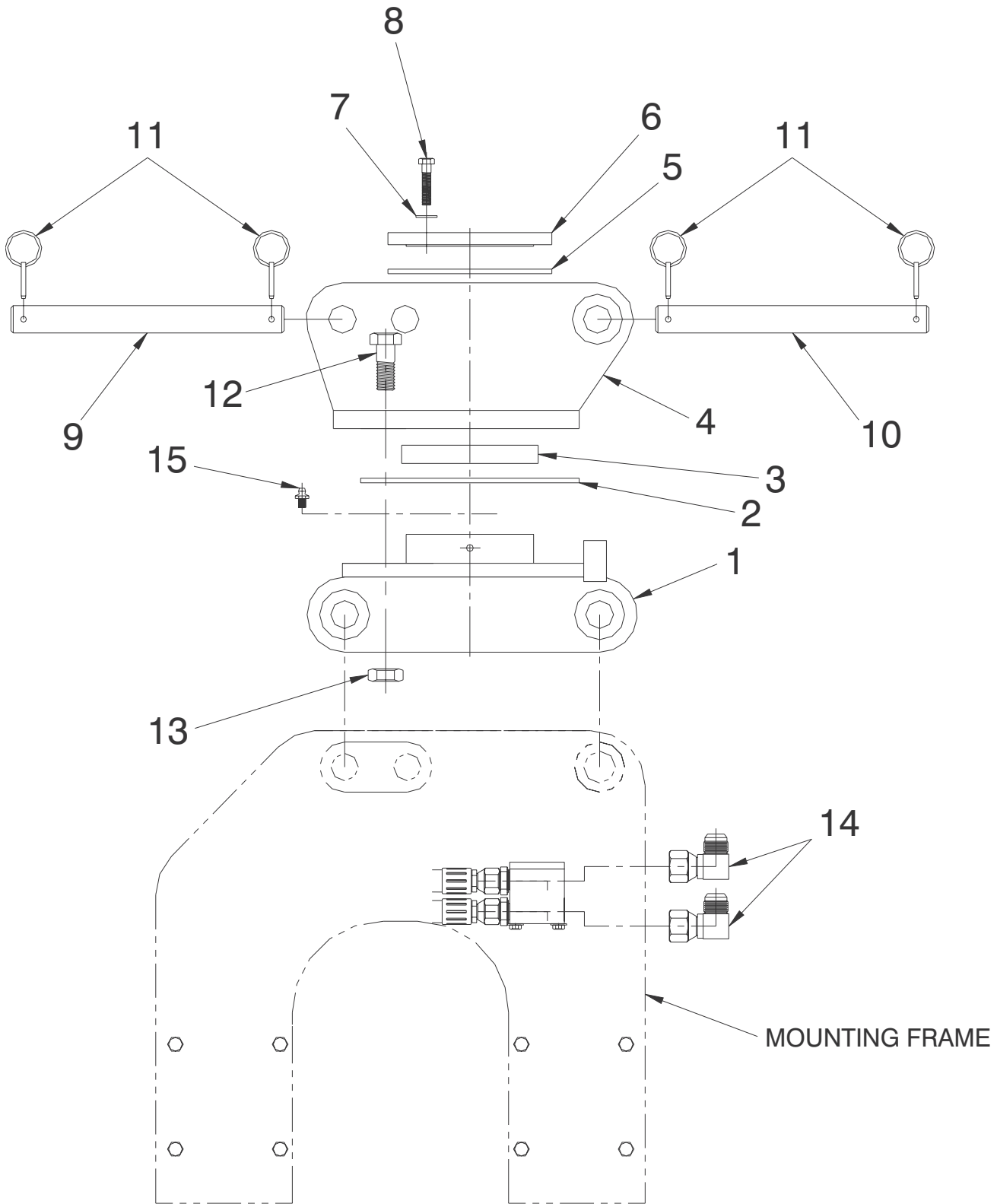

BSF Ho-Pac Swivel

BSF Ho-Pac Swivel Parts List Part No. 708808			
ITEM ONLY	QTY.	PART NO.	DESCRIPTION
1	1	708810	Swivel Base
2	1	617078	Lower Bearing
3	1	708594	Thrust Bushing
4	1	708809	Swivel Top
5	1	617079	Upper Bearing
6	1	617077	Thrust Plate
7	6	719021	Flat Washer
8	6	719710	Hex Head Cap Screw
9	1	617080	Boom Pin, 1.5" dia
10	1	653378	Boom Pin, 1.75 dia
11	4	617104	Klik Pin
12	1	551852	Hex Head Cap Screw
13	1	658837	Torque Nut
14	2	719163	90° Swivel Elbow (Replaces Item 7 BSF Ho-Pac)
15	1	798197	Lubrication Fitting
16	1		Standard Ho-Pac

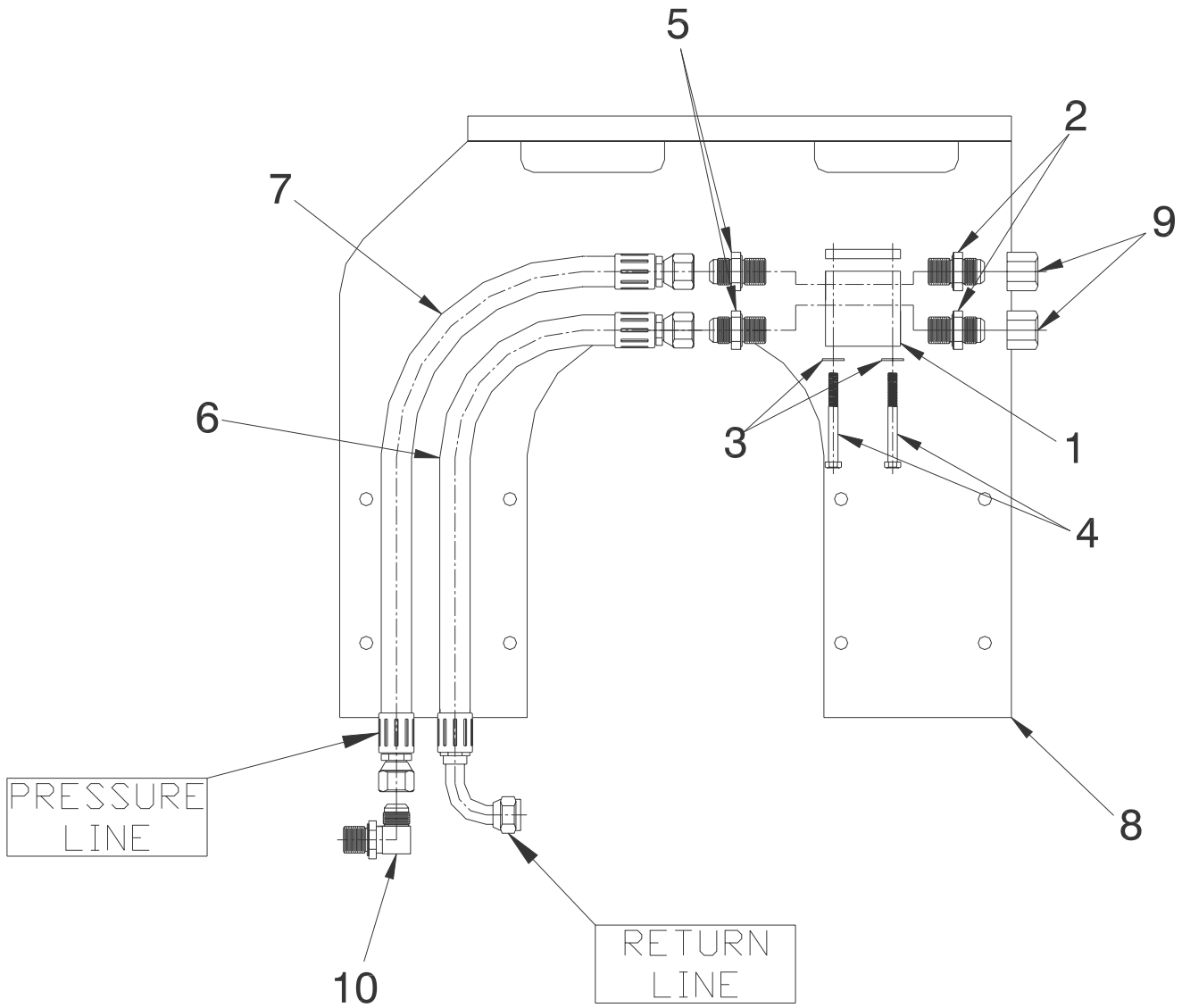

Custom Flat Top Ho-Pac Mounting Frame

Custom Flat Top Ho-Pac Mounting Frame Part No. 708563			
ITEM ONLY	QTY.	PART NO.	DESCRIPTION
1	1	708818	20 GPM Flow Regulator Valve (S/N 8849 & Below)
	1	103008	21 GPM Motor & Valve Pkg. (S/N 8850 & Above) Refer to Table 14.1
2	2	818329	Adapter
3	2	653339	Flat Washer
4	2	814213	Hex Head Cap Screw
5	2	656723	Adapter (S/N 8849 & Below)
	2	817521	45° Elbow (S/N 8850 & Above)
6	1	667775	Hose Assembly (Return) (S/N 8849 & Below)
	1	101824	Hose Assembly (Return) (S/N 8850 & Above)
7	1	679394	Hose Assembly (Pressure) (S/N 8849 & Below)
	1	101823	Hose Assembly (Pressure) (S/N 8850 & Above)
8	1	708554	Mounting Frame
9	2	101280	Hex Cap
10	1	656531	90° Elbow

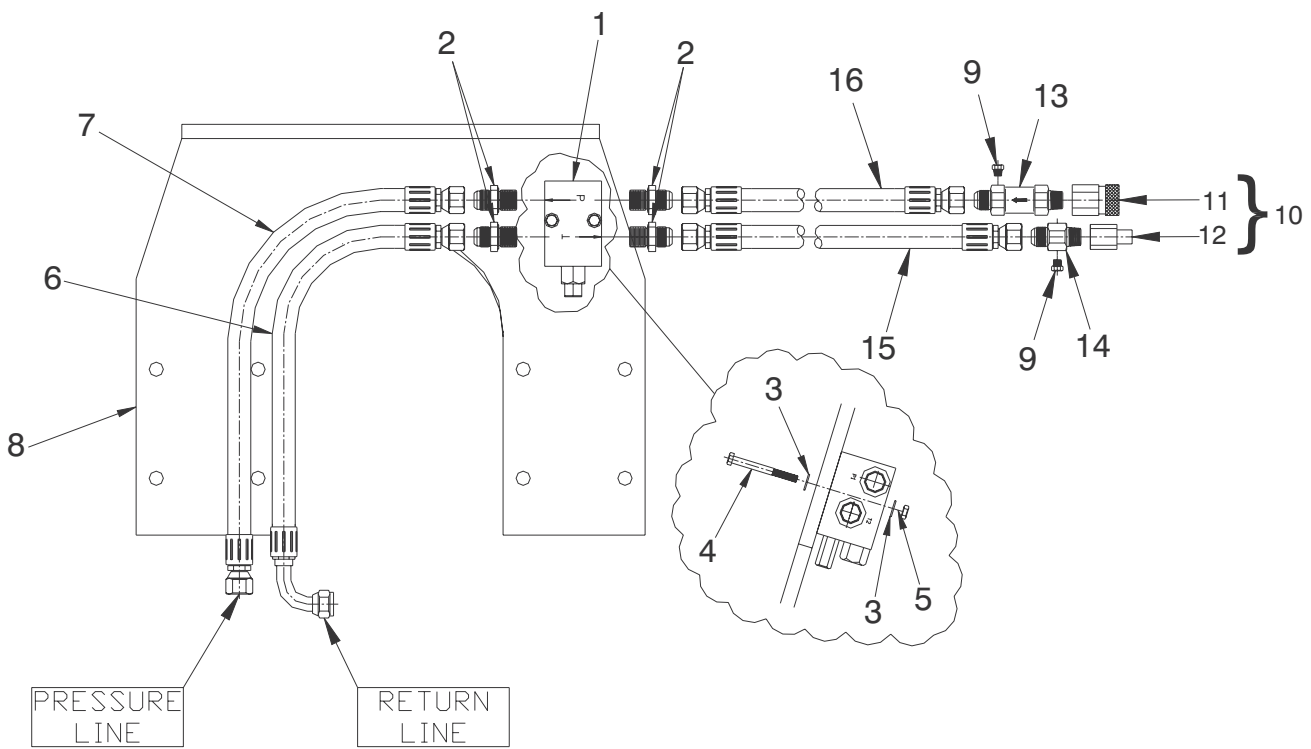

SCS Flat Top Ho-Pac Mounting Frame

SCS Flat Top Ho-Pac Mounting Frame Part No. 676752			
ITEM ONLY	QTY.	PART NO.	DESCRIPTION
1	1	708818	Flow Regulator Valve (S/N 8849 & Below)
	1	103008	Motor & Valve Package (S/N 8850 & Above) Refer to Table 14.1
2	4	656723	Adapter
3	4	653339	Flat Washer
4	2	679530	Hex Head Cap Screw
5	2	759808	Elastic Nut
6	1	101823	Hose Assembly (Return)
7	1	817604	Hose Assembly (Pressure)
8	1	676751	Mounting Frame
9	2	667566	Hex Head Plug (S/N 8849 & Below)
10	1	670006	Q.D. Coupling Package (Includes Items 11 & 12)
11	1	670007	Q.D. Socket
12	1	670008	Q.D. Plug
13	1	670270	Check Valve (S/N 8849 & Below)
14	1	708726	Adapter w/Port (S/N 8849 & Below)
15	1	678930	Hose Assembly (Return) (S/N 8849 & Below)
	1	102865	Hose Assembly (Return) (S/N 8850 & Above)
16	1	678931	Hose Assembly (Pressure) (S/N 8849 & Below)
	1	102865	Hose Assembly (Pressure) (S/N 8850 & Above)

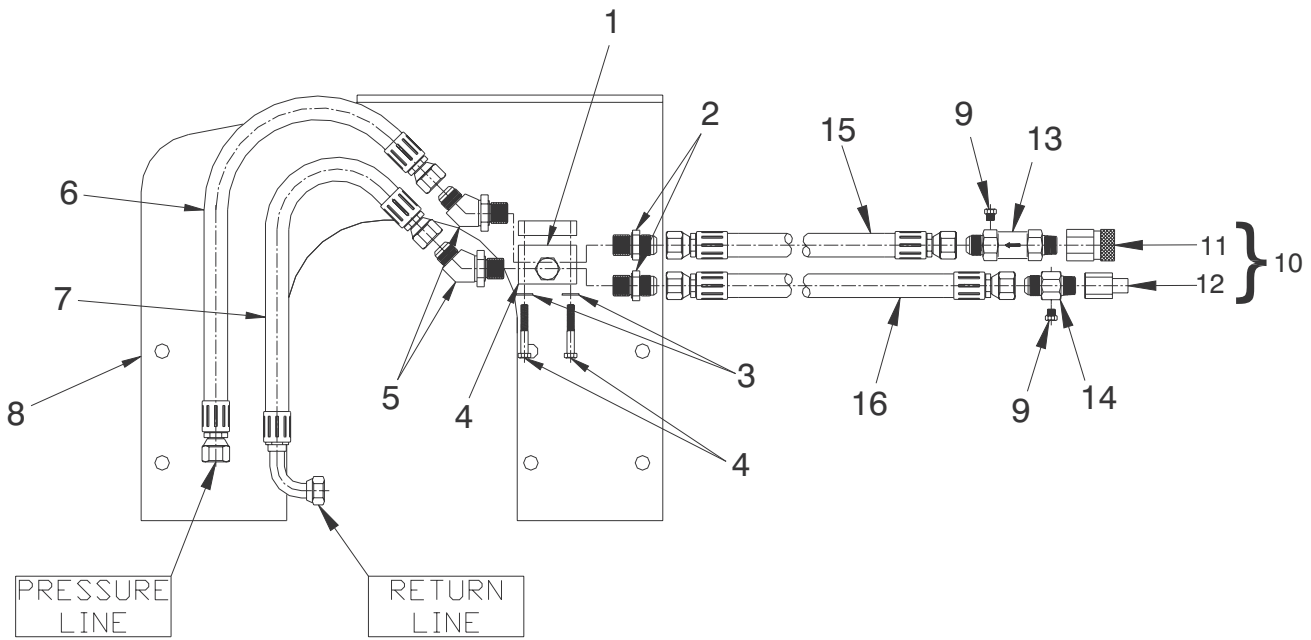

BCS Flat Top Ho-Pac Mounting Frame

BCS Flat Top Ho-Pac Mounting Frame Part No. 101460			
ITEM ONLY	QTY.	PART NO.	DESCRIPTION
1	1	676721	X-Line Check Valve (S/N 8849 & Below)
	1	Optional	Valve (S/N 8850 & Above) Refer to Table 14.1
2	2	656723	Adapter (S/N 8849 & Below)
	2	817521	45° Elbow (S/N 8850 & Above)
3	2	865384	Flat Washer (S/N 8849 & Below)
	2	653339	Flat Washer (S/N 8850 & Above)
4	2	870368	Hex Head Cap Screw (S/N 8849 & Below)
	2	814213	Hex Head Cap Screw (S/N 8850 & Above)
5	2	817521	45° Elbow
6	1	101824	Hose Assembly (Pressure)
7	1	101823	Hose Assembly (Return)
8	1	102133	Mounting Frame
9	2	667566	Hex Head Plug (S/N 8849 & Below)
10	1	670006	Q.D. Coupling Package (Includes Items 11 & 12)
11	1	670007	Q.D. Socket
12	1	670008	Q.D. Plug
13	1	670270	Check Valve (S/N 8849 & Below)
14	1	708726	Adapter w/Port (S/N 8849 & Below)
15	1	678931	Hose Assembly (Pressure) (S/N 8849 & Below)
	1	102865	Hose Assembly (Pressure) (S/N 8850 & Above)
16	1	678930	Hose Assembly (Return) (S/N 8849 & Below)
	1	102865	Hose Assembly (Return) (S/N 8850 & Above)

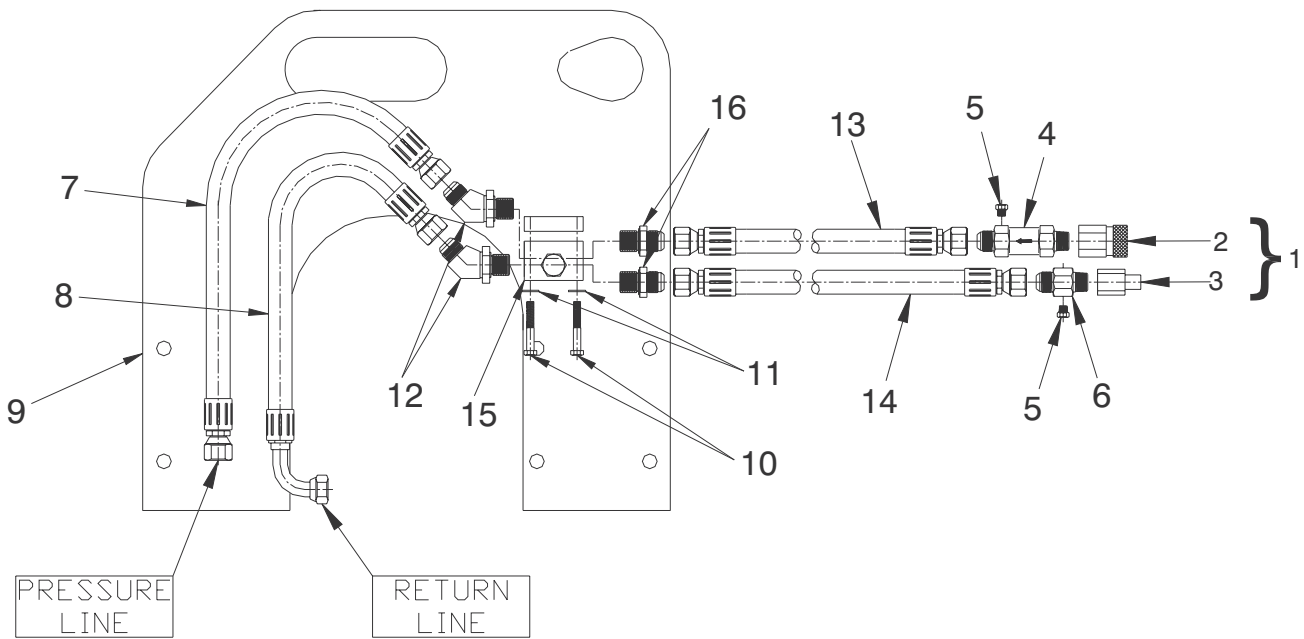

VMS V10 Ho-Pac Mounting Frame

VMS V10 Ho-Pac Mounting Frame Part No. 101553			
ITEM ONLY	QTY.	PART NO.	DESCRIPTION
1	1	670006	Q.D. Coupler Set (Includes Items 2 & 3)
2	1	670007	Q.D. Female Socket
3	1	670008	Standard Q.D. Male Plug
4	1	670270	Check Valve (S/N 8849 & Below)
5	2	667566	Hex Head Pipe Plug (S/N 8849 & Below)
6	1	708726	Adapter w/Port (S/N 8849 & Below)
7	1	101824	Hose Assembly (Pressure)
8	1	101823	Hose Assembly (Return)
9	1	101745	Mounting Frame
10	2	870368	Hex Head Cap Screw (S/N 8849 & Below)
	2	814213	Hex Head Cap Screw (S/N 8850 & Above)
11	2	865384	Flat Washer (S/N 8849 & Below)
	2	653339	Flat Washer (S/N 8850 & Above)
12	2	817521	45° Elbow
13	1	678931	Hose Assembly (Pressure) (S/N 8849 & Below)
	1	102865	Hose Assembly (Pressure) (S/N 8850 & Above)
14	1	678930	Hose Assembly (Return) (S/N 8849 & Below)
	1	102865	Hose Assembly (Return) (S/N 8850 & Above)
15	1	676721	X-Line Check Valve (S/N 8849 & Below)
16	2	656723	Adapter (S/N 8849 & Below)
	2	817521	45° Elbow (S/N 8850 & Above)

Table 14-1. Motor and Valve Package 12 gpm, 18 gpm or 21 gpm		
QTY .	Part No.	Motor and Valve Package (one of the following*)
1*	103006	Motor and Valve Package 12 gpm
1	101346	Hydraulic Motor 12 gpm
1	102650	Flow Regulator Valve 12 gpm
1*	103007	Motor and Valve Package 18 gpm
1	102668	Hydraulic Motor 18 gpm
1	102516	Flow Regulator Valve 18 gpm
1*	103008	Motor and Valve Package 21 gpm
1	102867	Hydraulic Motor 21 gpm (replaces 708777)
1	102652	Flow Regulator Valve 21 gpm

NOTE: Incorrect combinations of motor and valve can result in poor Ho-Pac performance or Ho-Pac damage.

This page intentionally
left blank.



3900 Kelley Avenue, Cleveland, Ohio 44114
Tel: 216-431-2600 Fax: 216-431-2601
e-mail: Sales@AlliedCP.com
website: <http://www.AlliedCP.com>
