

ALLIED

Concrete Cruncher®

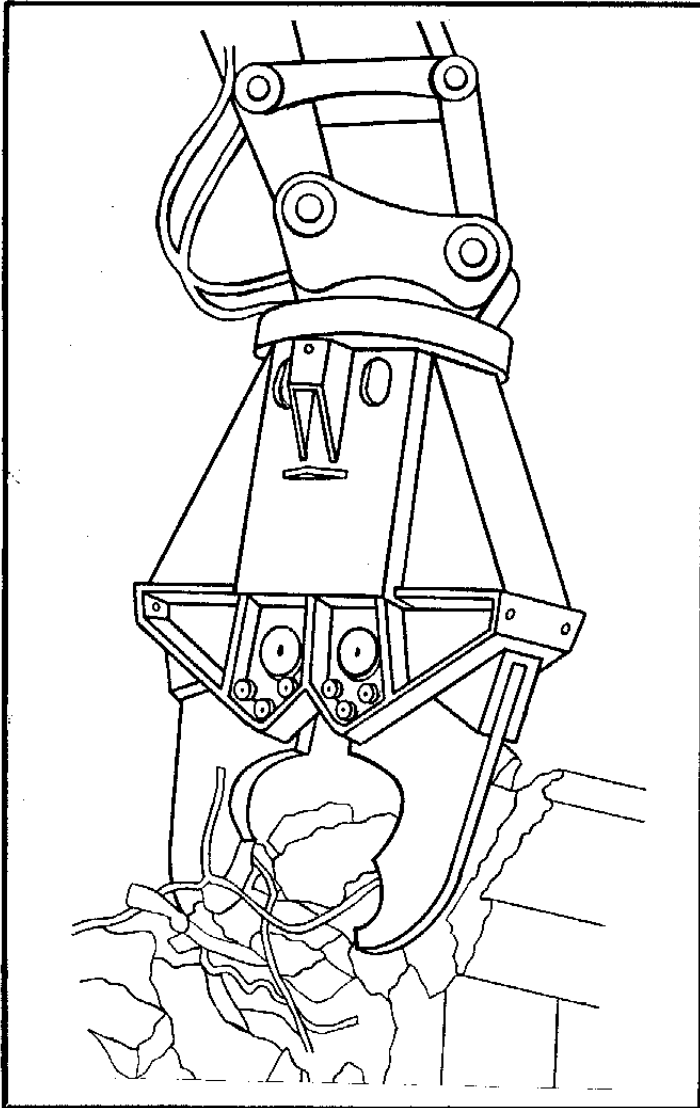

MODEL
ACC
24

**Boom Mounted
Hydraulic Operated
Concrete Crusher**

**OPERATION,
INSTALLATION,
SERVICE AND SAFETY
MANUAL**

**SPARE PARTS LIST
WARRANTY**



ATTENTION !

INSTRUCTIONS GIVEN WITH THIS SYMBOL ARE FOR PERSONAL SAFETY AND FULL SERVICE LIFE OF THE EQUIPMENT. FOLLOW THEM CAREFULLY.

OPERATION OR SERVICE OTHER THAN IN ACCORDANCE WITH THESE INSTRUCTIONS MAY SUBJECT THIS EQUIPMENT TO CONDITIONS BEYOND ITS DESIGN CAPABILITY. IMPROPER OPERATION OR SERVICING MAY RESULT IN EQUIPMENT FAILURE OR PERSONAL INJURY. READ THIS MANUAL THOROUGHLY BEFORE OPERATING OR MAINTAINING THIS EQUIPMENT.

1. INTRODUCTION

This manual is intended to provide operation and service instructions necessary for safe and efficient use of the Allied Concrete Cruncher.

Operators, maintenance and service personnel should carefully read this manual before attempting to operate or service.

2.0 UNIT SPECIFICATIONS

	U.S.	METRIC
Operating Weight	1235 lbs.	560 kg.
Hydraulic Pressure	2490-4450 psi	174-320 kg/cm ²
Closing Force	66,000-124,000 (lbs.)	30-56 (tons)
Carrier Size	.33-.52 (yd ³)	.25-.40 (M ³)

3.0 DIMENSIONS

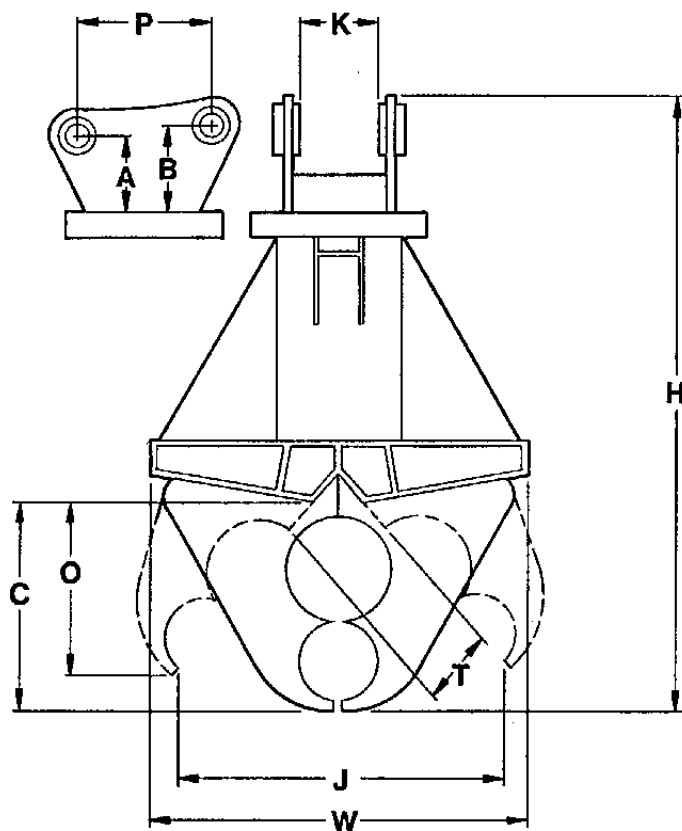

LTR.	U.S. (inches)	METRIC (millimeters)	LTR.	U.S. (inches)	METRIC (millimeters)
H	55	1397	O	12	310
J	24	610	K	10	260
T	6	145	P	16	396
W	36	914	A	9.25	235
C	14	360	B	11	290

4.0 CARRIER RECOMMENDATIONS - ACC-24 CRUNCHER

The power and control of the Cruncher is provided by the hydraulic system of the excavator or other carrier to which the Cruncher is mounted.



Never operate on a carrier which has hydraulic pressure over 4550 p.s.i. (320 kg./cm²). Excessive high pressure may cause damage to the equipment.

Follow the installation recommendations in this manual for the most productive results. The ACC-24 should never be installed on an excavator exceeding .52 cu.yd./ .40 M3 capacity. CONTACT ALLIED TECHNICAL SERVICE FOR FURTHER INFORMATION.

5.0 OPERATION FEATURES

- a. Twin cylinders allow for minimum cycle time, fast opening and maximum penetration forces.
- b. Free rotator and wider jaw opening, which translate into greater versatility and reduce stress on carrier.
- c. Detects on swing rotator prevent dangerous movement during transport and repositioning.
- d. A unique rotating mechanism incorporates an abrasive resistant durable polymer resin material which protects the rotating and sliding areas, which are otherwise susceptible to wear due to dust, dirt and debris.
- e. The cutting blades are recessed into the mounting jaws to control penetration depths.

6.0 CRUNCHER SYSTEM

When teamed with hydraulic excavators, the Allied Cruncher demolishes concrete building components such as beams, pillars and intermediate supports. Concrete is simply separated from reinforcing rod by the crushing action of the units power jaws.

In some situations, suspending the Cruncher from a crane may facilitate underwater operation, work in pits or high level work, not accessible by an excavator. Hydraulic power is provided by an independent stationary hydraulic power unit.

For full productive use of the Cruncher, observe all the guidelines stated in this manual. For specific hydraulic installation requirements, see Section 8.3, Hydraulic Installation.

6.1 CRUNCHER BASIS COMPONENTS LIST

1. Hydraulic Supply Lines
2. Boom Pin
3. Upper Rotator Body
4. Cylinder Supply Lines
5. Swivel Joint
6. Cylinder Pin
7. Cylinder Cover
8. Cylinder Assembly
9. Lower Rotator Body
10. Jaw Blade
11. Jaw Mounting Pins
12. Nylon Bearing Surfaces

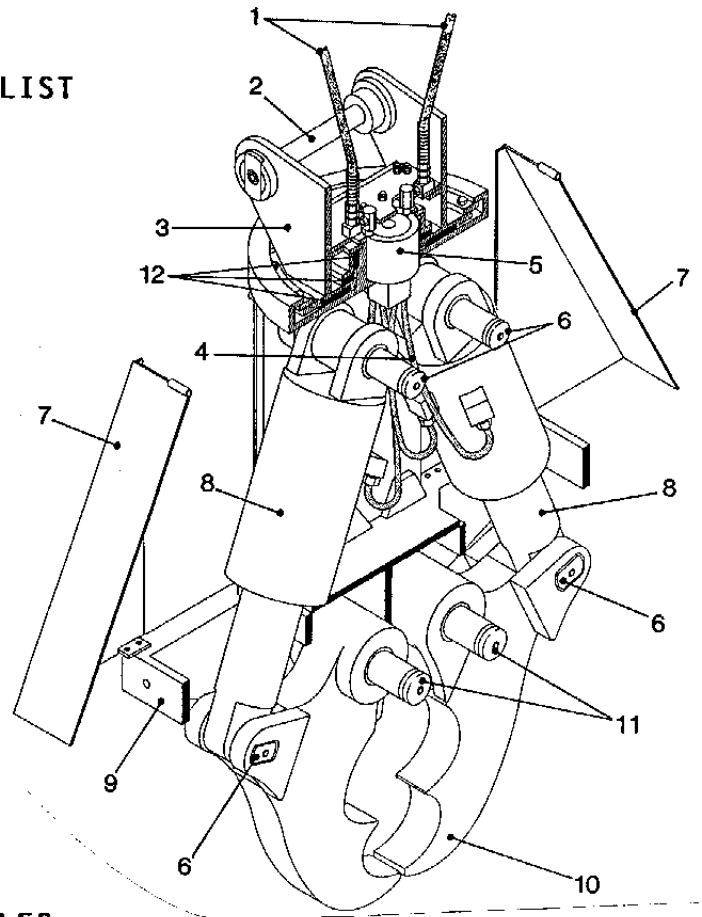

6.2 CRUNCHER OPERATION PRINCIPLES

The upper rotator body (3) is mounted to the carrier by boom pins (2). The upper rotator turns independently of the lower rotator body by sliding on three (15, 16 and 20) lubricated nylon bearing surfaces - fully enclosed - by the structure of the Cruncher. Hydraulic oil supplied by the carrier is transferred to and from the hydraulic cylinders (8) by passage through a unique swivel joint. Connecting hydraulic lines (1). Cylinders are pinned at the lower rotator body and the center of the jaw. As the piston reacts to hydraulic pressure, the jaws close by reaction with the fulcrum created at the jaw mounting pins (11).

To create controlled rotator of the upper and lower rotator bodies, spring loaded detects (not shown) index the rotator. Turning of the lower rotator body to position jaws is accomplished by pressing the closed assembly to the structure to be demolished.

Diagonal grasping of material, which reduces crushing force, is reduced by the jaws adjusting themselves to a right angle by the power and mechanical action of the cylinders causing the lower rotator body to move in reaction to the stationary upper rotator body. This action reduces the need for refined positioning of the excavator before engaging the material.

For detailed descriptions of various operating components and periodic maintenance, see Section 11 - 16.

7.0 PRODUCT IDENTIFICATION

For expedient handling of inquiries, always have the serial number noted. Serial numbers are stamped on the Cruncher on the inside of the upper rotator and is stamped on the lower part of jaw box and lower rotator.

8.0 INSTALLATION GUIDELINES

8.1 CARRIER REQUIREMENTS

To adequately maneuver and handle the Cruncher, an excavator within the recommended size range must be used, consult the Specifications, Section 2.0. The hydraulic circuit selected for the carrier or other supply, must meet minimum pump output requirements at 180°F. oil temperature. In addition, excess flow may be needed for simultaneous operation. The quantity dependent on pump type, normal pump wear and excavator circuitry.

8.2 CRUNCHER MOUNTING

Mount and orient the Cruncher to the carrier as shown in Figure 1. Note location of excavator stick with relation to hydraulic hoses and port locations. Use mounting components specified or approved by Allied Technical Service.

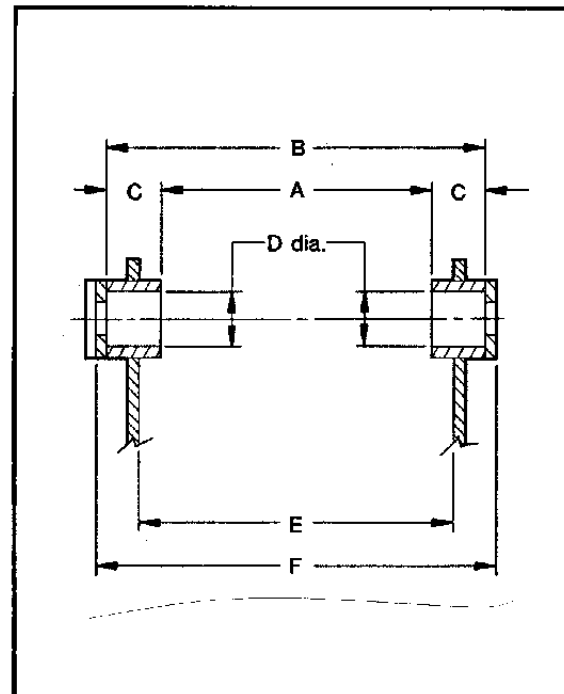
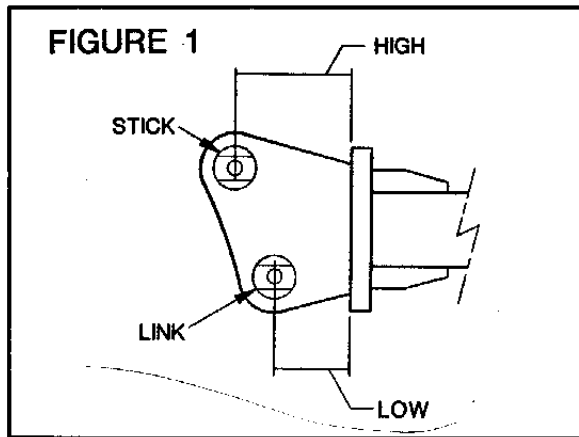

	ACC 24	ACC 35	ACC39	ACC59
A	10 1/4"	12 7/8"	16 1/8"	16 1/8"
B	14 1/4"	20 7/8"	20 7/8"	20 7/8"
C	2"	4"	2 3/8"	2 3/8"
D	3.07"	4.61"	4.61"	4.61"
E	12"	17 3/4"	17 3/4"	18 5/8"
F	15"	21 5/8"	21 5/8"	21 5/8"

STICK AND LINK DIMENSIONS ARE THE SAME AND ARE SUBJECT TO CHANGE. CONTACT ALLIED TECHNICAL SERVICE FOR FURTHER INFORMATION.

8.3 HYDRAULIC INSTALLATION KITS

An Allied hydraulic installation kit may be necessary to install the Cruncher. Each kit is designed for a specific carrier model and includes all necessary fittings, hoses, valves and hardware for hookup.

Units installed on excavators also used for operating Hy-Rams may also be used for Crunchers with slight modification.

Consult the specific installation kit instructions for proper connections and routing, the schematic or plumbing diagrams for basic connection guidance.

Contact your distributor or Allied Technical Service Department for further information.



9.0 GENERAL CONSTRUCTION SAFETY

The standard procedures that are expected or required of those working in construction should be followed including location of existing utility service lines, establishing pedestrian barriers and personal protective equipment.

Use the Cruncher in accordance with all state and local safety ordinances. In addition, comply with the recommendation of the occupational safety and health standards of the U.S. Department of Labor. For OSHA construction guidelines, contact your local federal government office, bookstore or write: U. S. Government Printing Office, Superintendent of Documents, Washington, D. C. 20402. Ask for construction industry standards 29 CFR 1926/1910 and all revisions.



10.0 SAFETY PRECAUTIONS

- ✓ Inspect hydraulic circuit for leaks or other signs of physical damage.
 - ✓ Replace hydraulic hoses and lines where a hazard may be indicated. Observe pressure rating and use only Allied replacement parts.
 - ✓ Never use the Cruncher jaws for other than the intended purpose, such as to pry or pick.
 - ✓ Never stand or climb on the Cruncher or excavator stick or boom while the hydraulic system of the carrier is operable. Carrier engine should be shut down and hydraulic pressure in lines depleted before inspecting Cruncher.
-



10.0 SAFETY PRECAUTIONS

- ✓ Never attempt to lubricate, service or disassemble Cruncher without disconnecting hydraulic lines.
- ✓ Never operate an Allied Concrete Cruncher on a carrier larger than recommended. Excessive stress on the Cruncher could result in twisted or broken components and personal injury.
- ✓ Never operate a Cruncher with hydraulic pressure greater than specified. Install appropriate relief valve as recommended by Allied Technical Service.
- ✓ Always follow the mounting-dismounting procedure. Never attempt to attach or detach a Cruncher if footswitch can be accidentally activated.
- ✓ Work should be carried out either directly in front or behind the hydraulic excavator. Operating over excavator sides should be avoided, since this causes the hydraulic excavator to become unstable.
- ✓ The excavator should be operated in such a way that the machine is leveled and securely positioned. Special care is needed when operating the machine on top of piles of rubble or on a slope.
- ✓ When demolishing structures, take special care to ensure that fragments of concrete and other material do not fall on top of the operator or equipment.
- ✓ When the machine is being operated on upper floors, verify the load strength of the floor surface. Depending on how the equipment is operated, the floor may be subjected to loads in excess of the dead weight of the machinery itself.
- ✓ Use of excavators undersize in weight of those recommended, could cause dangerous overturning.

11.0 PREPARATION FOR OPERATION AND ROUTINE MAINTENANCE

11.1 PRIMARY INSTALLATION

See Section 8.0 for guidelines for selection of carriers and installation of hydraulic installation kits and mounting hardware. Observe all instructions and diagrams. If further information is needed, contact your distributor or Allied Technical Service Department.

11.2 OPERATION GUIDELINES

Section 12.0 thru 16.0 cover the basics of storing handling, and special applications. Read and follow these carefully.

12.0 ROUTINE STORAGE

- ✓ Store unit in dry location, on blocks.
- ✓ Lubricate all points.
- ✓ Position of jaws should be open.
- ✓ Always cap hydraulic lines to prevent dirt and moisture from entering system.
- ✓ For storage longer than thirty days, be certain hydraulic components such as cylinders are oil filled before capping off.

13.0 ROUTINE LUBRICATION RECOMMENDATIONS

Use the following high temperature grease on all lubrication points listed and shown in Figure 2. Follow this guideline for proper lubrication of the Cruncher. Unless visual observation of joint permits assurance of lubrication flow, use a lever action grease gun and attempt several smooth shots of grease. If extreme resistance is encountered, lubrication fitting must be removed and lubrication channel cleaned with a stiff wire.

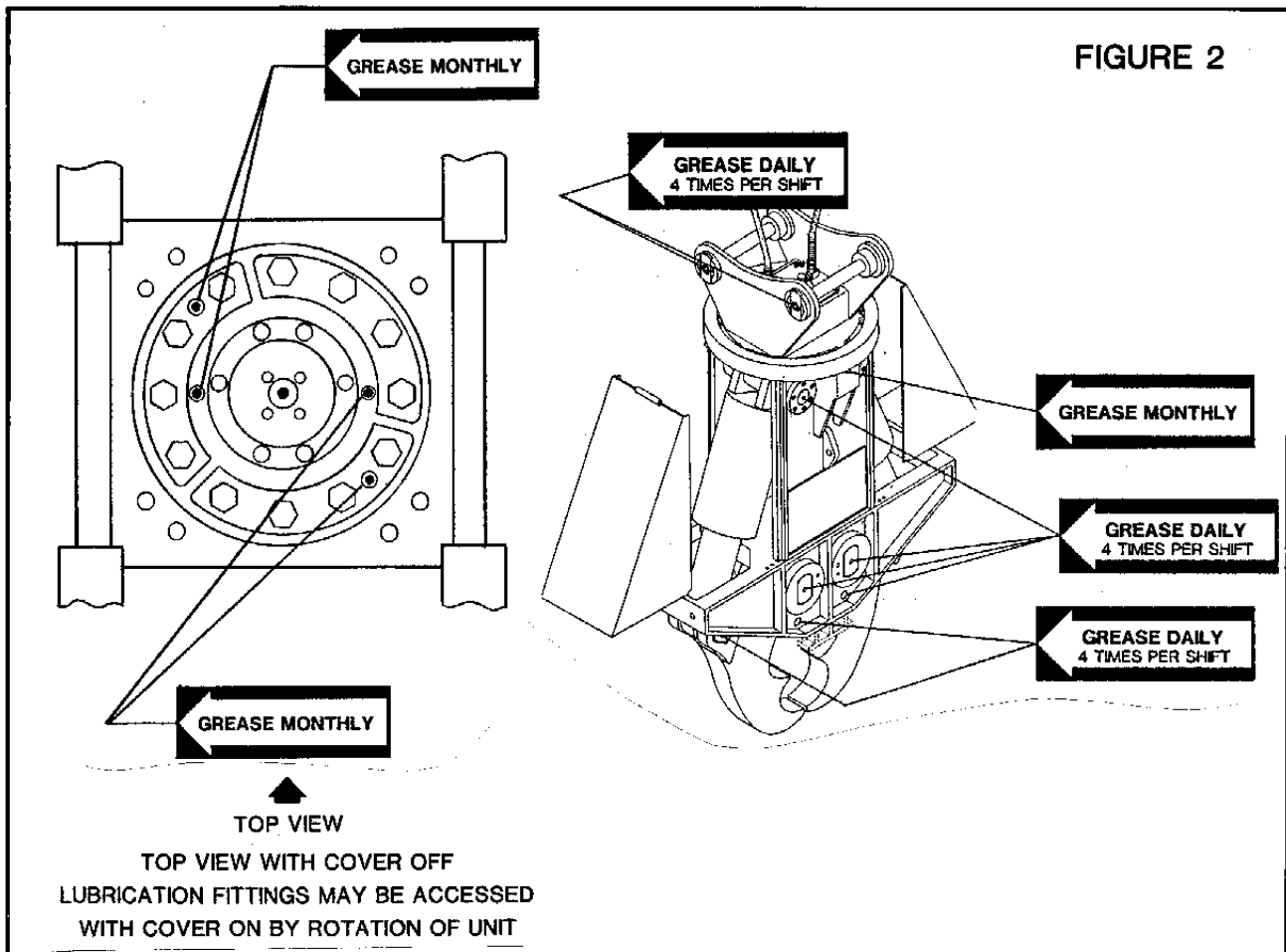

LUBRIPLATE 3000 OR EQUAL

Lithium Base

Molybdenum Disulfide - more than 3%

Dropping Point F deg. - 450^o - 500^o

Viscosity at: 100^o F - 1900 - 2200 and 210^o F - 125 - 130

13.0 ROUTINE LUBRICATION RECOMMENDATIONS

- a. Lubricate the following, once per month or more frequently in extreme service conditions:
1. Lubrication fitting at ball decent component (30), (2 total).
 2. Lubrication fittings at housing retainer plates (4), (2 places), and rotator retaining plates (17), (2 places, 4 total).
 3. Lubrication fittings at boom pin (51), (total 2).
- B. Lubricate the following four times per shift, starting at the beginning of each shift:
1. Lubrication fittings at jaw adjustment plate (39), (total 4). Lubricate until grease oozes out slightly between adjustment plate and jaw, see Figure 3.
 2. Lubrication fitting at each upper cylinder pin (33), (total 4).
 3. Lubrication fittings at each jaw retaining pin at jaw (35), (total 2).
 4. Lubrication fitting at each lower cylinder pin (33), (total 2).

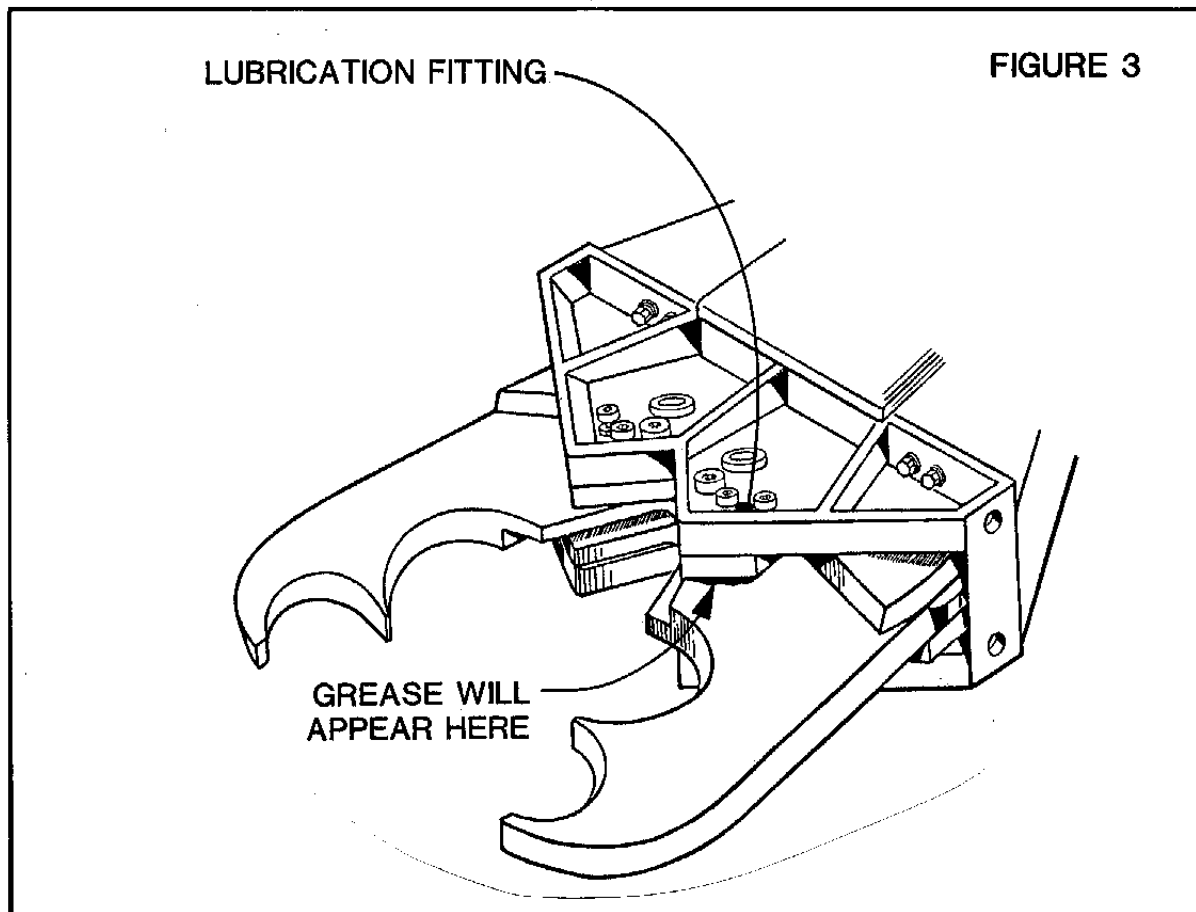

14.0 UNDERWATER APPLICATION

Daily use of the Allied Cruncher for underwater operation either partially or fully submerged may be performed if the following are performed:

- ✓ Before initial submersion, lubricate ALL points.
 - ✓ Lubricate during shift per recommendations in Section 12.0.
 - ✓ Open jaws to full wide position to retract cylinder pistons, at end of shift.
 - ✓ Lubricate all points at end of shift.
 - ✓ Store unit on blocks out of direct contact with water.
-

15.0 PROPER HANDLING FOR TRAVEL AND TRACTORING TO AND FROM WORK SITE

Moving carrier around work site:

Observe all techniques common with operating heavy equipment. Close jaws of the Cruncher and tuck under boom to help prevent loss of control.

Trailing carrier and Cruncher:

Carrier and Cruncher can best be transported to and from job site by positioning carrier on trailer with jaws of Cruncher open and tucked around base of boom section. This method protects cylinder piston rods as required under Section 12.0, Routine Storage.

16.0 OPERATION GUIDELINES

Before attempting operation read all previous Sections 1.1 thru 15.0 and observe all precautions and practices.

Cruncher Start-Up.

Observe routing lubrication as noted in Section 12.

Never activate Cruncher, idle opening and closing which results in sharp jaw to jaw contact.



Clicking of jaws together could result in chipping of hardfacing and potential flying material. Read and observe Section 19.1 for further information.

For best long term performance and service life, unit should be warmed up before heavy crushing is performed:

Start excavator according to standard practice allowing hydraulic system to warm up.

16.0 OPERATION GUIDELINES

Activate jaws by simulating opening and closing action above ten times.

In extremely cold weather, perform light crushing work for 15 minutes before attempting heavy crushing.

The Allied Cruncher was designed for demolishing of reinforced concrete, concrete block, rock and brick. DO NOT use for other purposes without a project appraisal by Allied.



Under no circumstances should workers or by-passers be permitted within the working radius of the carrier while crushing, plus fifty feet. Serious injury could result from flying or falling debris.

Never intentionally twist the cruncher while attempting crushing action. Such action imposes extreme loads on cruncher and carrier. When crushing difficulty is encountered unclamp and attempt a "BITE" in a different location or attempt several to form fracture line. See Figure 4.

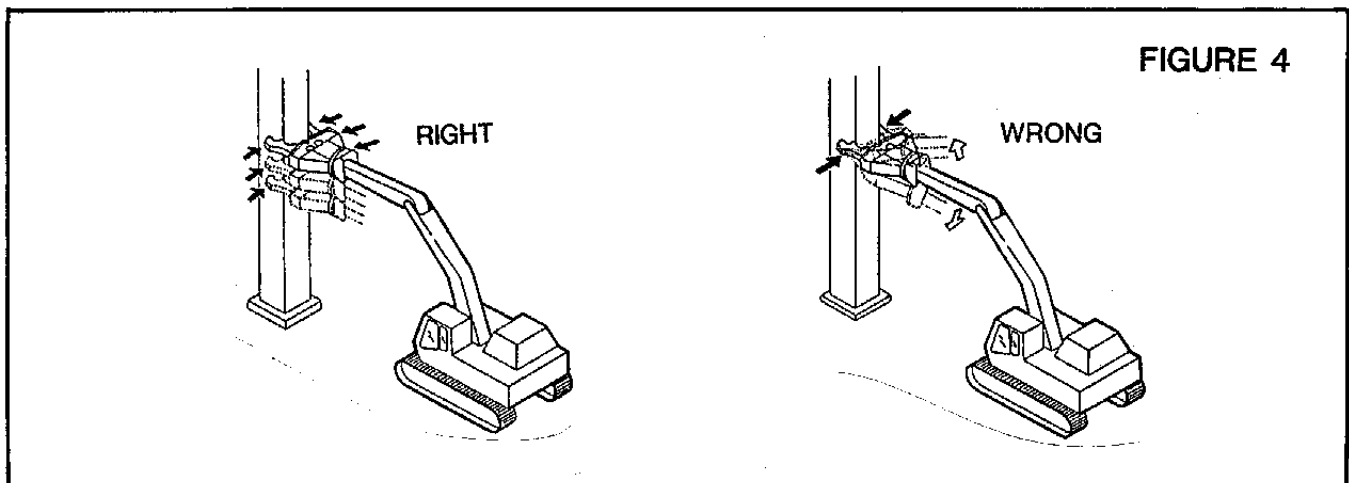

If during crushing, long protruding reinforcement bar is in direct line of the crusher, first use the cruncher jaws to bend the bars away, up to a 90° angle from the line of approach. This will minimize potential for a re-bar threading its way around protective covers and damaging hoses and fittings inside, see Figure 5.

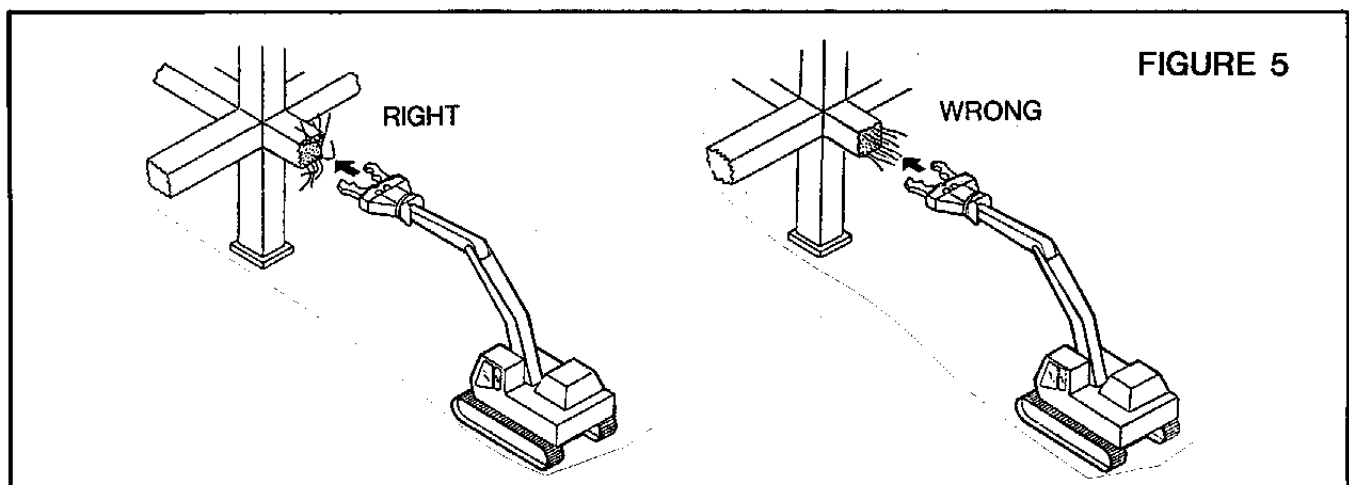

16.0 OPERATION GUIDELINES

Water spray may be used to control dust, however maintain cruncher is in Section 13.

The cruncher has a self rotating feature to prevent jamming and twisting as shown in Figure 6.

When crushing an object where the angle of approach cannot be adjusted by the operator, the lower rotator will be reaction force adjust itself to the work.

Do not attempt to operate cruncher in areas too narrow to allow rotator, or attempt to lock the upper and lower rotator thru some form of alteration. Loss of efficiency and reduced service life could result.

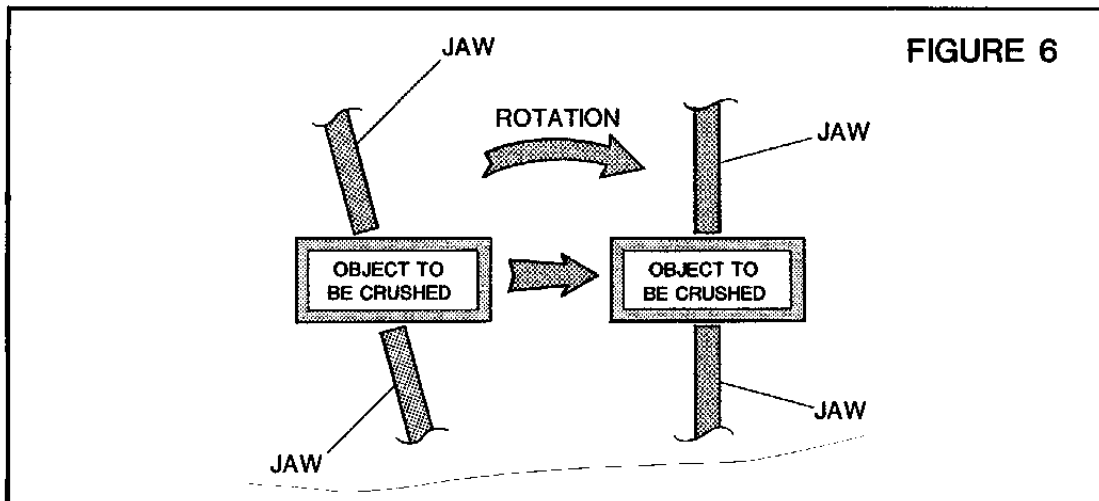

17.0 DISASSEMBLY OF ALLIED CRUNCHER

17.1 GENERAL DISASSEMBLY GUIDELINES

A suitable handling device such as an overhead or jib crane will be necessary for complete disassembly in order to handle heavy components such as cylinder and jaws.

Inspect the Cruncher and see Figure 10 for relationship of inlet and outlet lines (close and open) of Cruncher. Maintain this relationship during reassembly process.

Ports shown should be disconnected and capped to prevent unnecessary loss of oil and potential contamination to hydraulic system.



Cylinder assembly weighs 1000 lbs. or more depending on model. Other components are equally heavy. Handle with equipment and techniques customary with service of heavy equipment.

17.2 DISASSEMBLY PROCEDURE

Where possible we have indicated how subassemblies of the Cruncher may be serviced without performing an entire disassembly procedure.

The upper rotator assembly is best serviced with the Cruncher upright standing on the lower rotator frame with jaws removed. However, service on upper rotator assembly may also be performed with the unit laying on blocks. Alignment of various components is more difficult and time consuming.

CYLINDER AND JAW DISASSEMBLY - SEQUENCE

Cylinders and jaws may be removed for service or inspection independently of each other, however, the most efficient sequence for service and inspection of the lower assembly is as follows:

REMOVAL OF CYLINDER COVERS

The cylinder covers are made of heavy steel and should be removed for service of the Cruncher internal components. Severe injury could result from accidental closing.

To remove covers remove cover bolts (22) from lower cover end and hinge pin (24). Set covers aside until service is complete. Cylinder cover bolt has 24 mm. hex.

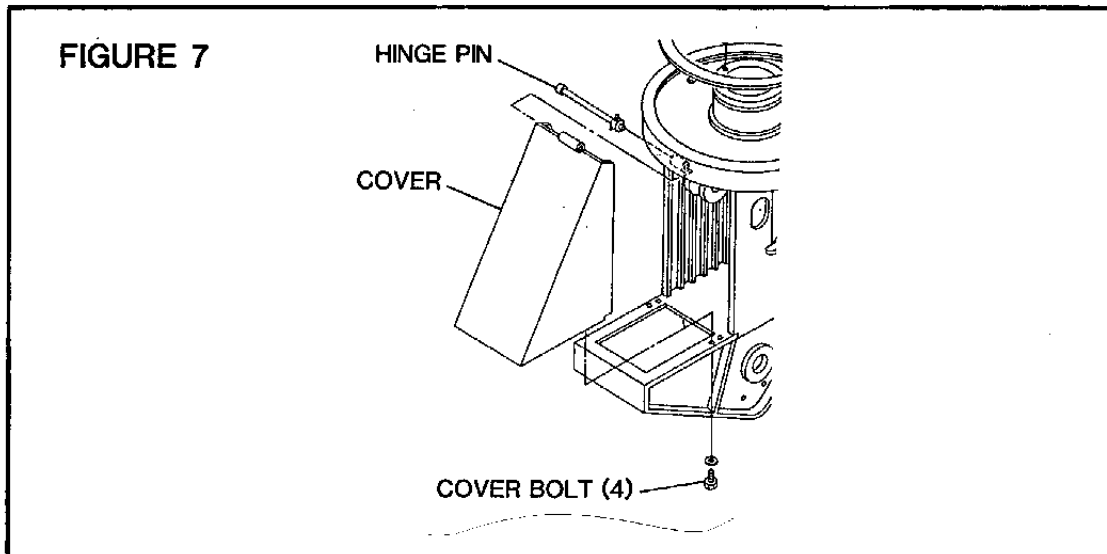

REMOVAL OF CYLINDER ASSEMBLIES

If cylinder covers have not been removed see Section on Removal of Cylinder.

Position of unit: flat on work area floor resting on 4 x 4 blocking. Lifting eye of lower rotator facing up.

Cylinder assemblies should be removed from lower rotator body mounts for inspection and replacement of piston rod wiper seals. Cylinder piston head seals are not considered a service item. These steel seals are specially designed to be self-flushing for long life. Contact Allied Technical Service for further information.

REMOVAL OF CYLINDER ASSEMBLIES

- a. Lifting sling should be used as in Figure 8 to relieve weight on cylinder assembly.

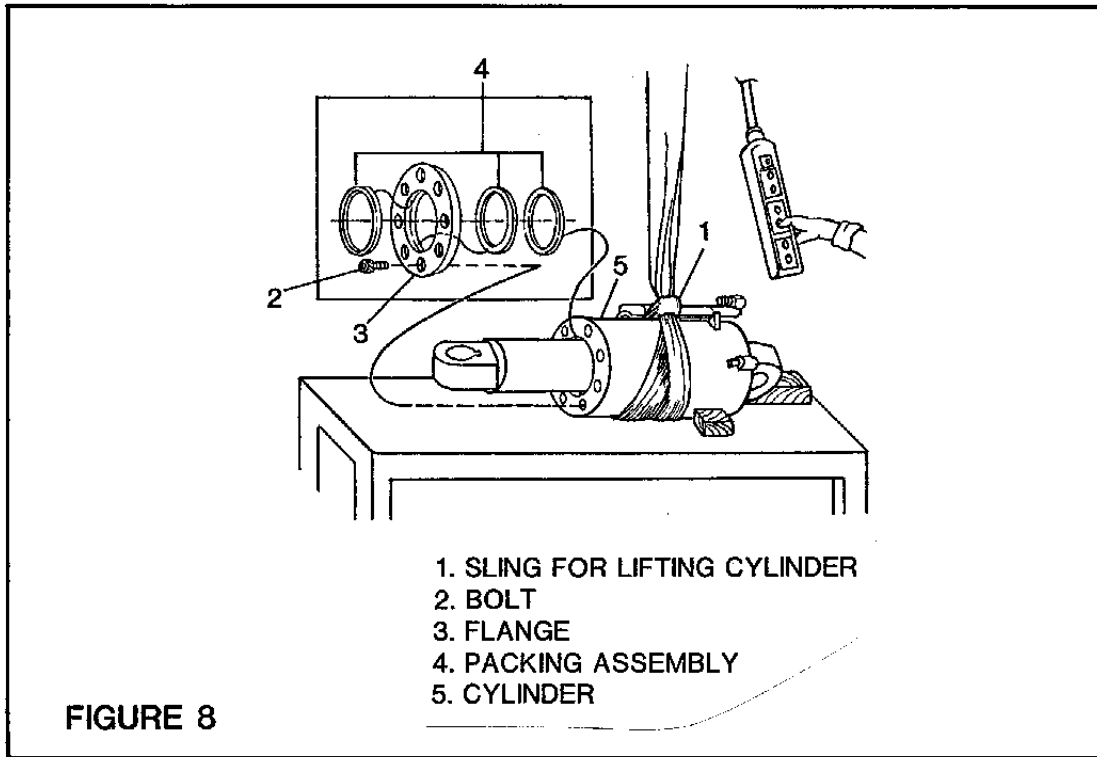

- b. Remove upper jaw retaining pin (35) by removing retaining ring (34).
- c. Swing cylinder out and disconnect hydraulic hoses. Use 27 mm. hex wrench on return lines. Use 36 mm. hex wrench on inlet lines.

Inspect hoses for wear or cracking.

- d. With cylinder supported remove retaining ring (34) and drive out pin (33).
- e. Swing cylinder assembly clear of unit and stabilize on heavy work bench with blocking. Leave lifting sling attached for additional safety. If cylinders are not to be serviced store in clean, dry area with piston retracted fully.
- f. Remove second cylinder in same fashion as the first.

REMOVAL OF JAW ADJUSTMENT PLATE

- a. To remove and service jaws, at least one jaw adjustment plate must be removed after jaw adjustment bolts are unthreaded.
- b. It may be necessary to pry plate due to buildup of dust and grease.
- c. Remove second adjustment plate when Cruncher is in convenient position.

Inspect adjustment plates for:

- ✓ Broken lubrications fittings
- ✓ Clogged lubrication passage way
- ✓ Galling of plate surface

REMOVAL OF JAWS

At this point the jaw is held in place at the jaw retaining pin (35). If cylinders have not been removed, jaws may be removed by disconnecting piston rod end only with cylinder supported by upper mounting pin and blocking.

- a. Support jaw as shown in Figure 9 using lifting sling.
- b. With weight of jaw supported remove (35) jaw retaining pin. The jaw retaining pin is retained by stop rings (37) and pin stop (36). Use 10 mm. hex Allen wrench for socket head cap screws (38).
- c. Remove second jaw in same manner as first.
- d. Removal of second spacer plate (39) is recommended for cleaning of built-up debris caked on sliding surfaces. Inspect lubrication nipple (14) and passageway in spacer. Removal is most conveniently performed after unit is positioned upright.

FIGURE 9

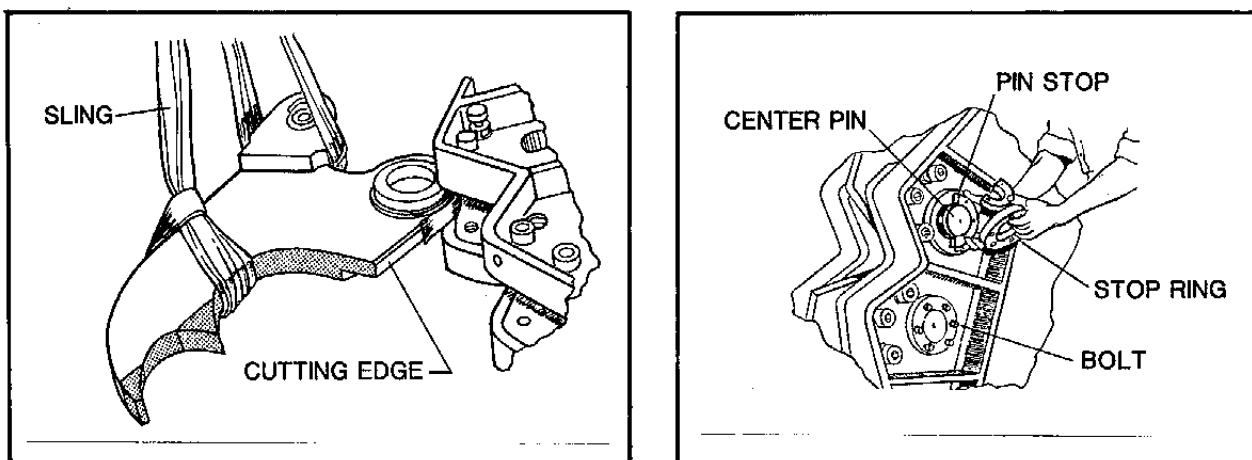

REMOVAL OF JAWS

For servicing of jaws see Section 20. Inspect jaws and pins for:

- Worn jaw bar cutter
- Worn or chipped hard surface weld
- Cracked or broken teeth
- Jaw to adjustment plate galling
- Inspect pins for broken lubrication fittings
- Clean pin lubrication passages

If jaws are to be serviced, see Section 19.1. If complete disassembly, inspection and reassembly is intended proceed to Section called Disassembly of Upper Rotator Assembly from Lower Rotator Assembly and Swivel Joint.

DISASSEMBLY OF UPPER ROTATOR ASSEMBLY FROM LOWER ROTATOR ASSEMBLY AND SWIVEL JOINT

In order to conveniently perform disassembly the unit should be stood upright on lower rotator frame (1). Stabilize with blocking as necessary.

NOTE: Before further disassembly of the unit observe the relationship of hydraulic fittings and ports to the lubrication fittings per Figure 10. Note relationship of stick and link positions and lifting eye. Observation of these relationships will prevent "opposite operation" in jaw function.

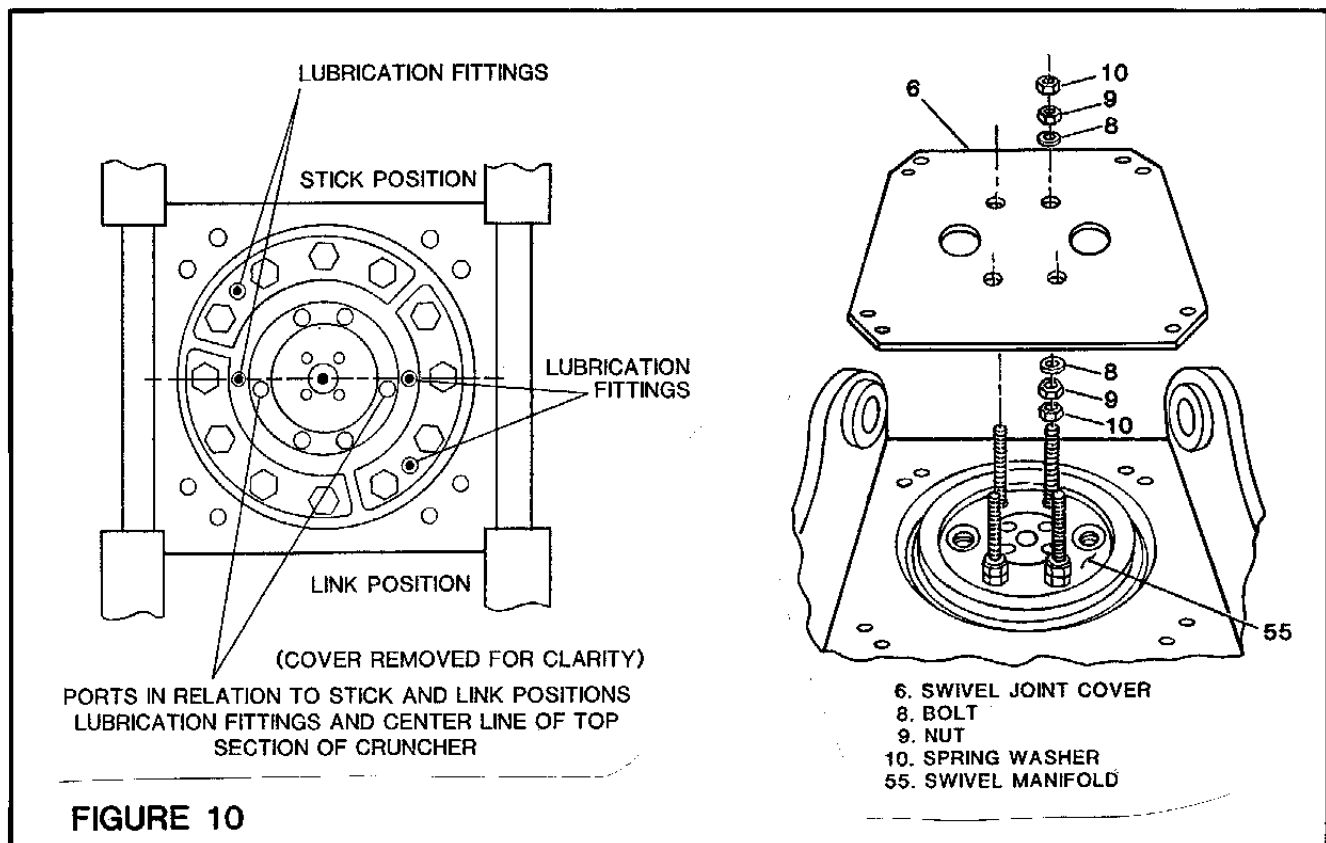

FIGURE 10

HYDRAULIC FITTINGS

Remove all hydraulic fittings from top of unit including items 7, 48, 43 and 47, per Figure 10.

SWIVEL JOINT COVER

Remove swivel joint cover (6) by removal of four pairs of nuts (8 and 9) and retaining bolts and washers (11 and 12). Cover will lift off, exposing to of swivel joint.

UPPER ROTATOR AND BEARING COMPONENTS

With a clear view of the upper assembly, now prepare to remove upper rotator as follows (refer to Figure 11):

- a. Remove outer rotator retaining plates (17), (8 total), by removing bolts and washers (18) and (19). Plates may be held fast by compacted grease and dust, pry out from lip of lower rotator body with small pry bar or pick. See Figure 11.
- b. As shown in Figure 11, the upper rotator is also retained at bearing housing (13). Remove housing retainer plates (3 total) by removing three bolts and washers (11 and 12). Retainers may require prying.
- c. See Figure 12. Upper rotator housing may now be removed by lifting. Use long pins through stick and link positions and suitable forged chain.
- d. Upper rotator has three components which must be removed for cleaning and inspection; see Figure 13.
- e. Set housing (2) aside noting location of nylon plate (20) which may be stuck to underside.

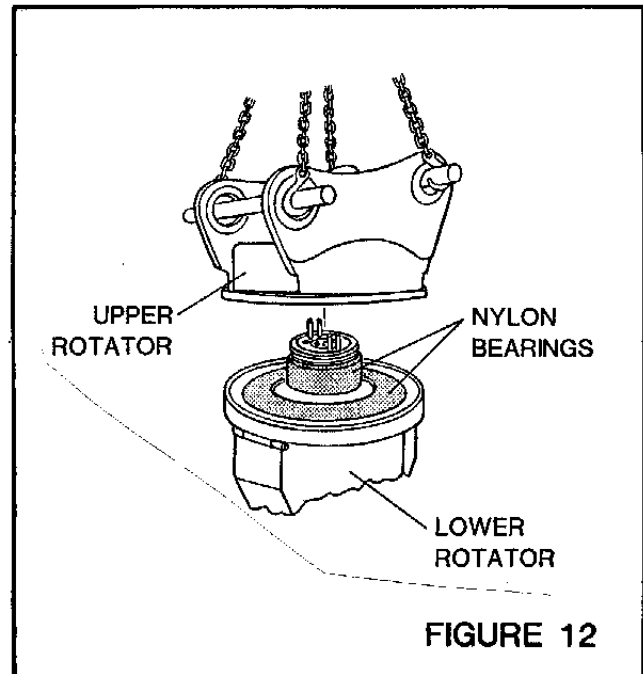
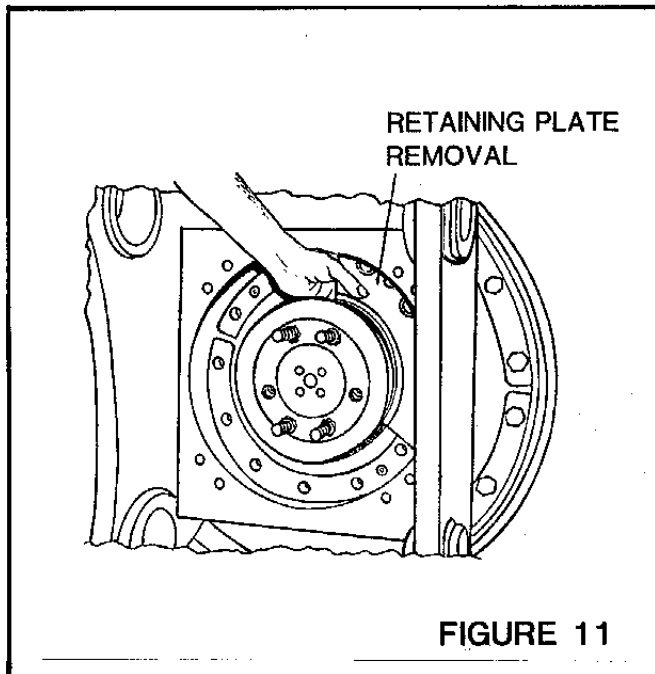

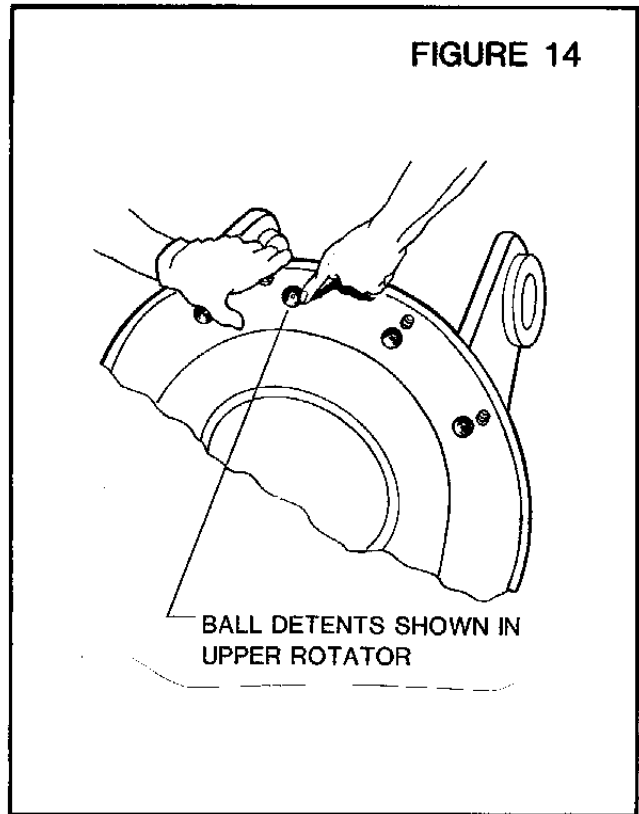
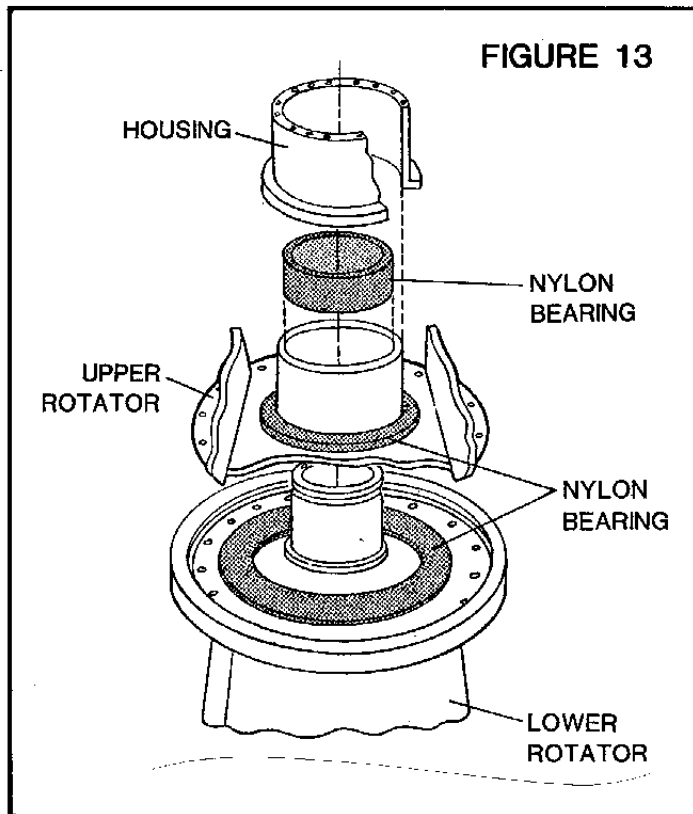

DETENT BALL STOP ASSEMBLY/DISASSEMBLY AND SERVICE

With routine lubrication ball detents will require only infrequent disassembly to remove caked grease. Follow this sequence:

- a. Loosen lock nut (31) and remove adjustment bolt (32).
- b. Remove stop cap (30) and pull out remainder of detent stop components.

Inspect lubrication fitting as necessary. Keep ball detents clean see Figure 14.

SWIVEL JOINT DISASSEMBLY

The swivel joint assembly may be removed for disassembly or cylinder hose replacement after cover (6) is removed. The unit is keyed to the lower rotator by a square shank on the inner manifold. Use cover studs (total 4) to pull the unit out.

The unit is held together by the cover which has four bolts which are removed for seal inspection/replacement.

HOSE REPLACEMENT

Replace hoses in sets only. Hoses may be removed without complete unit disassembly. To gain access to hoses, observe instructions for Cover Removal and Swivel Joint Disassembly. Cylinders may be swung out for hose access.

18.0 REASSEMBLY INSTRUCTIONS

18.1 GENERAL ASSEMBLY

Observe all safety precautions listed in section 10.0, and those denoted in the disassembly procedure section 17.0. Assemble in reverse order of assembly instructions observing the following special assembly guidelines.

18.2 REASSEMBLE

Remember on reassembly to observe the following:

- a. Relationship of center line of top of unit, lubrication fittings and hydraulic ports as shown in Figures 2 and 10.
- b. The lifting eye on the lower rotating body is always to the same side as the high boom pin eye, stick side, of the upper rotator.
- c. All metal to metal bearing surfaces should be cleaned and relubricated before reassembly.
- d. Nylon bearing located between upper rotator and lower rotator components Figure 13, should be thoroughly cleaned and coated with recommended lubricant, see section 13, before reassembly.
- e. After assembly, lubricate to fill appropriate cavities preparation for daily lubrication schedule, Section 13.0.

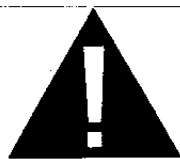

Never attempt operation after assembly with co-workers near the working jaws of the cruncher. Serious injury could result.

- f. After assembly, unit is to be operated open and close at least 10 times to check for:
- g. Proper adjustment of jaw alignment. Bolts, item 40.

NOTE: Adjust jaw plate bolts until contact tight and then back off 1/2 turn. Lubricate until a small bead of grease shows between jaw and plate.

- h. Proper tightness of all fasteners.
- i. Inspection for and correction of improperly tightened hydraulic fittings.
- j. Store according to section 12.
- k. Torque valves are available from Allied Technical Service Department, as well as common bolt head sizes, for tool section.



19.0 JAW DESIGN AND PROPER OPERATION

The jaws have been hardfaced with an abrasion resistant weld rod. Direct interference of the extremely hard material (A) of one jaw with the other should be avoided, such as clicking of the jaws together during idle operation or assembly/disassembly. Injury could result, from flying chips. When rebuilding or rehardfacing attempt to restore the original shape. Leave a slight gap at (B), when cylinders are closed.

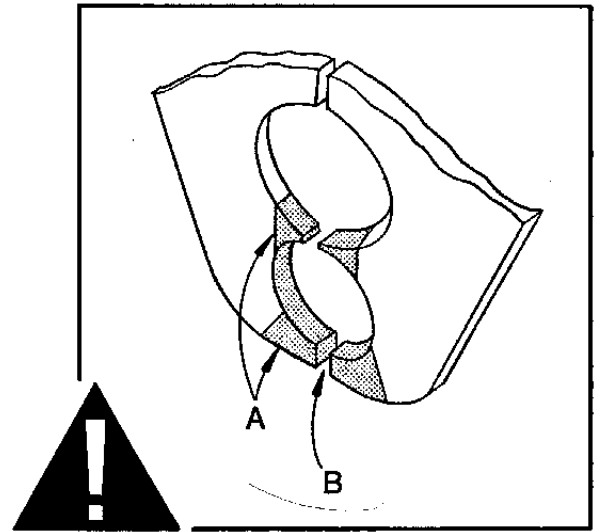

19.1 HARDFACING PROCEDURE LOWER JAW AREA (A, B)

1. To clean up, lightly skip grind, if old hardfacing is to be removed, use gas torch, then skip grind.
2. Observe recommendation in Section 19.0 above.
3. Rehard face with the following weld rods or (or equal):* HF-600, HF-800 - *Kobe Steel Ltd. Pre-heat to 575^oF/300^oC in cold weather.

USE 3 PASSES TO BUILD UP FULLY

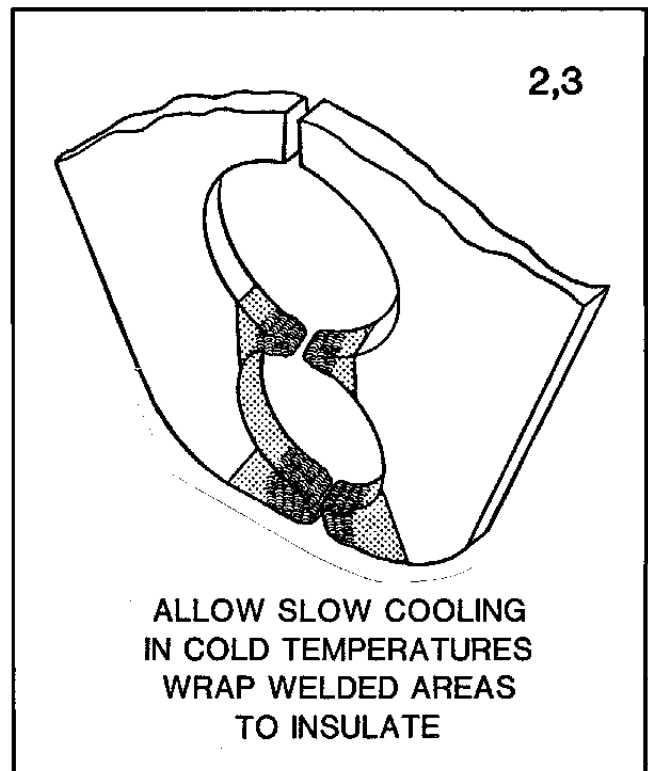
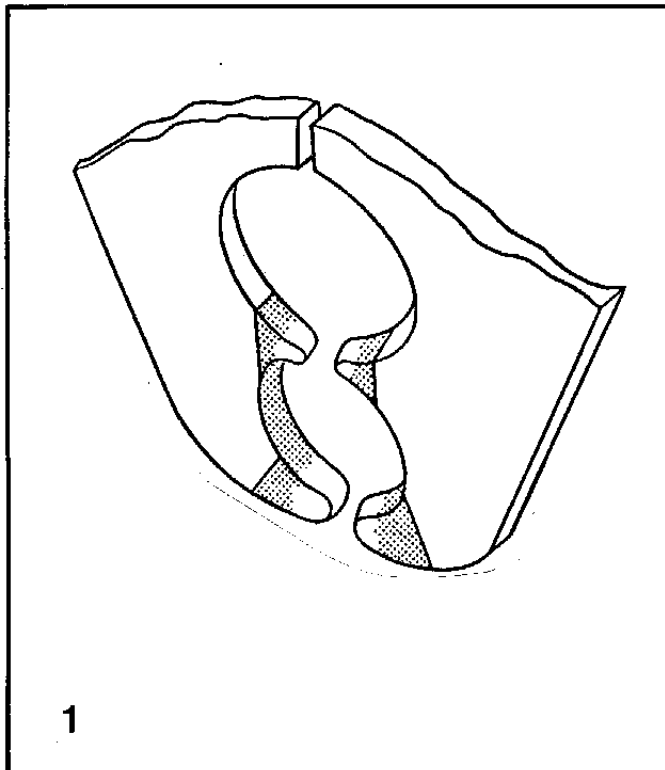

19.2 REBUILDING OF SEVERELY WORN JAWS

Perform rebuilding as follows:

- a. Jaws are worn to the point hardfacing provides insufficient buildup.
- b. Square off worn areas.
- c. Using high tensile steel, form replacement pieces observing guidelines in Section 19.1.
- d. Use weight of jaws (not activated) to hold pieces in place (or clamp). Be certain a minimum of $1/2 \times 45$ weld chamfer is ground on all mating pieces 360° . Preheat jaw for 20 minutes using torch. Weld with (or equal): * Kobe LB-52 (AWS-E7016) *Kobe Steel.
- e. Cut pieces in two with torch; hardfacing per Section 19.0 and 19.2.

***NOTE:** Adhere to Allied technical data sheets Ref. 1251, 1252, 1253, 1254 for use of weld rods listed or in selecting direct substitutes.

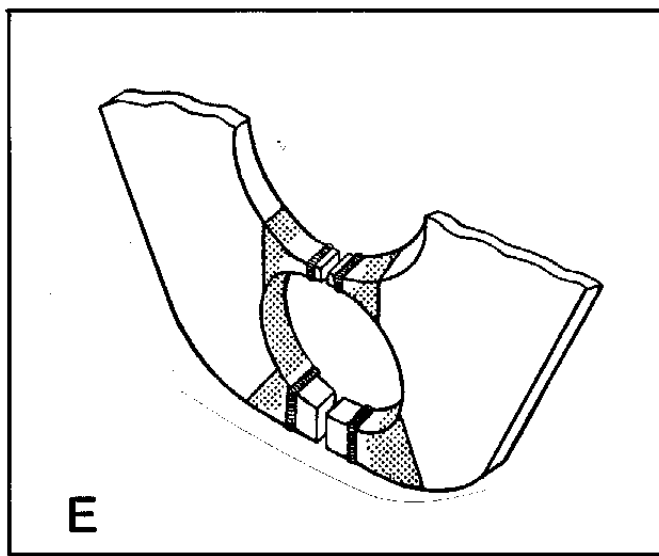
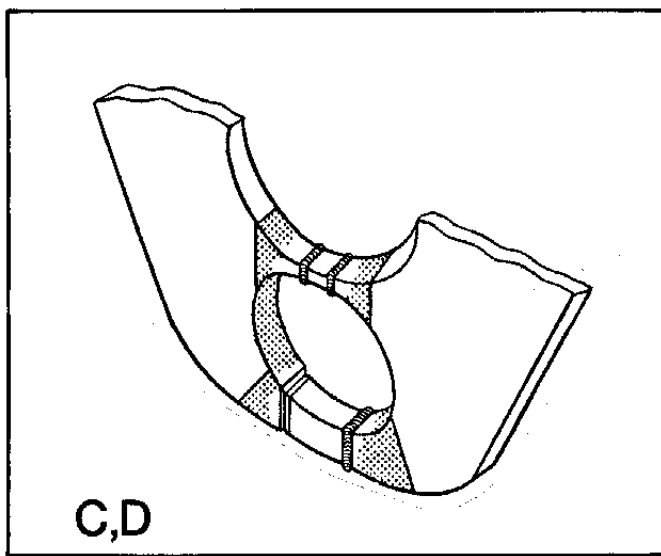
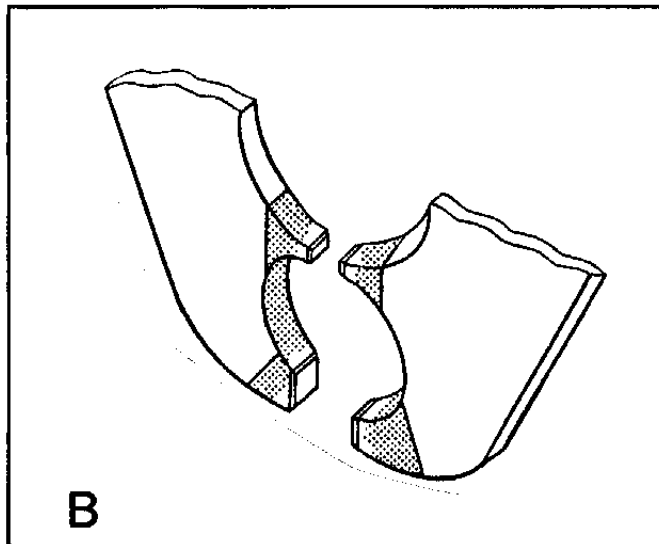
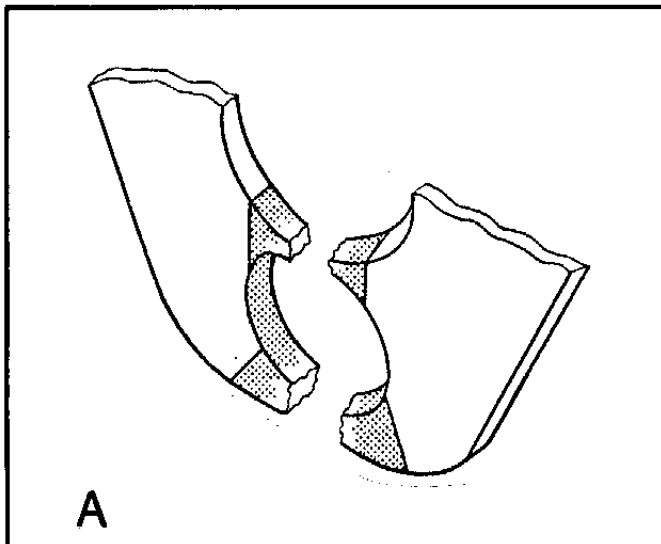

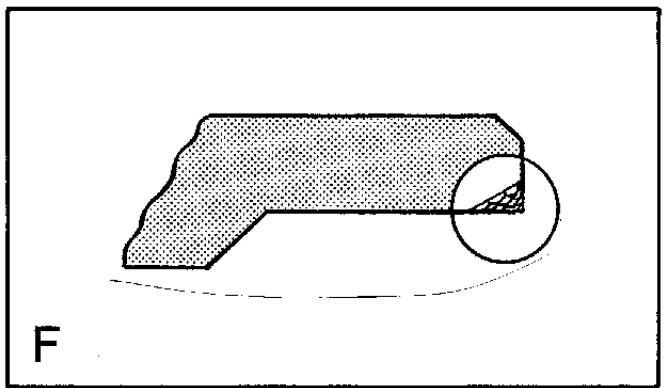
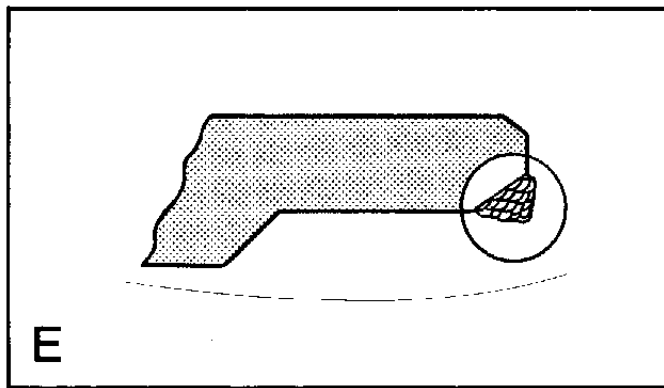
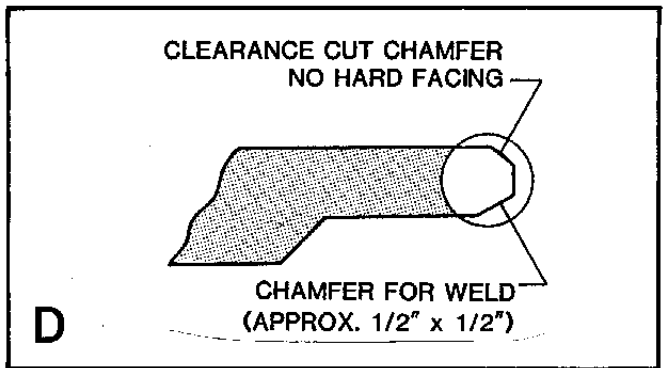
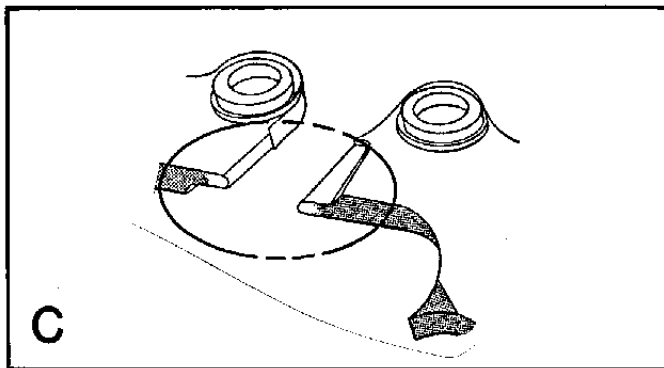
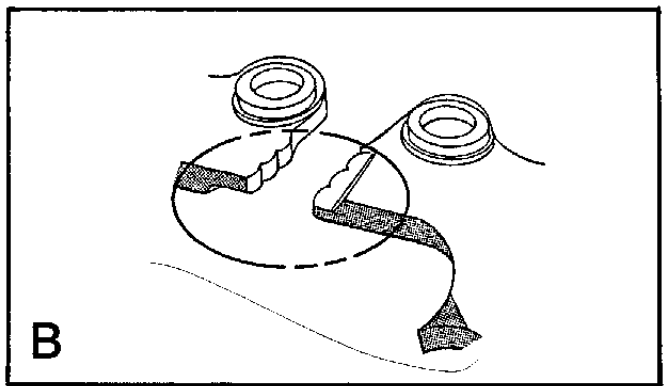
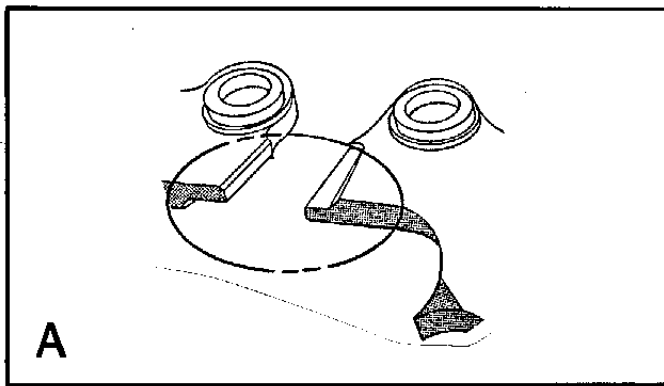

- a. A new jaw or one which is carefully rebuilt will look like the above. Note the chamfered surfaces and the overlapping cutter which allows the cut re-bar to clear the cutter.
- b. A severely worn cutter, which requires complete rebuilding of base material and hardened cutting edge. Skip grind to clean up. Proceed to Figure C.
- c. Build up worn base material of jaws to near new thickness with LB-52 (AWS-E7016) weld rod or equal. Proceed to Figure D.
- d. Grind for clearance cut chamfer (top) and chamfer for cutter hard facing. Proceed to Figure E.
- e. Weld hardfacing using HF11-30-CR rod (AW-EFEMN-A-or-B) or equal. Number of passes is limited. Proceed to Figure F.
- f. Hardfacing is then leveled and sharpened with a grinder.

NOTE: (instead of D,E,F) Another method is to use HF-800K rod in one pass over a well profiled base. This material is extremely hard and cannot be machined.

DECAL LOCATIONS

PART NO.	QTY.	DESCRIPTION
658824	2	ALLIED LOGO (FOR ACC 24, 35)
659919	2	ALLIED LOGO (FOR ACC 39, 59)
961039	1	DANGER, STAY CLEAR (FOR CRUNCHER)
961040	1	DANGER, STAY CLEAR (FOR OPERATORS CAB)
964080	4	GREASE MONTHLY
964081	10	GREASE DAILY

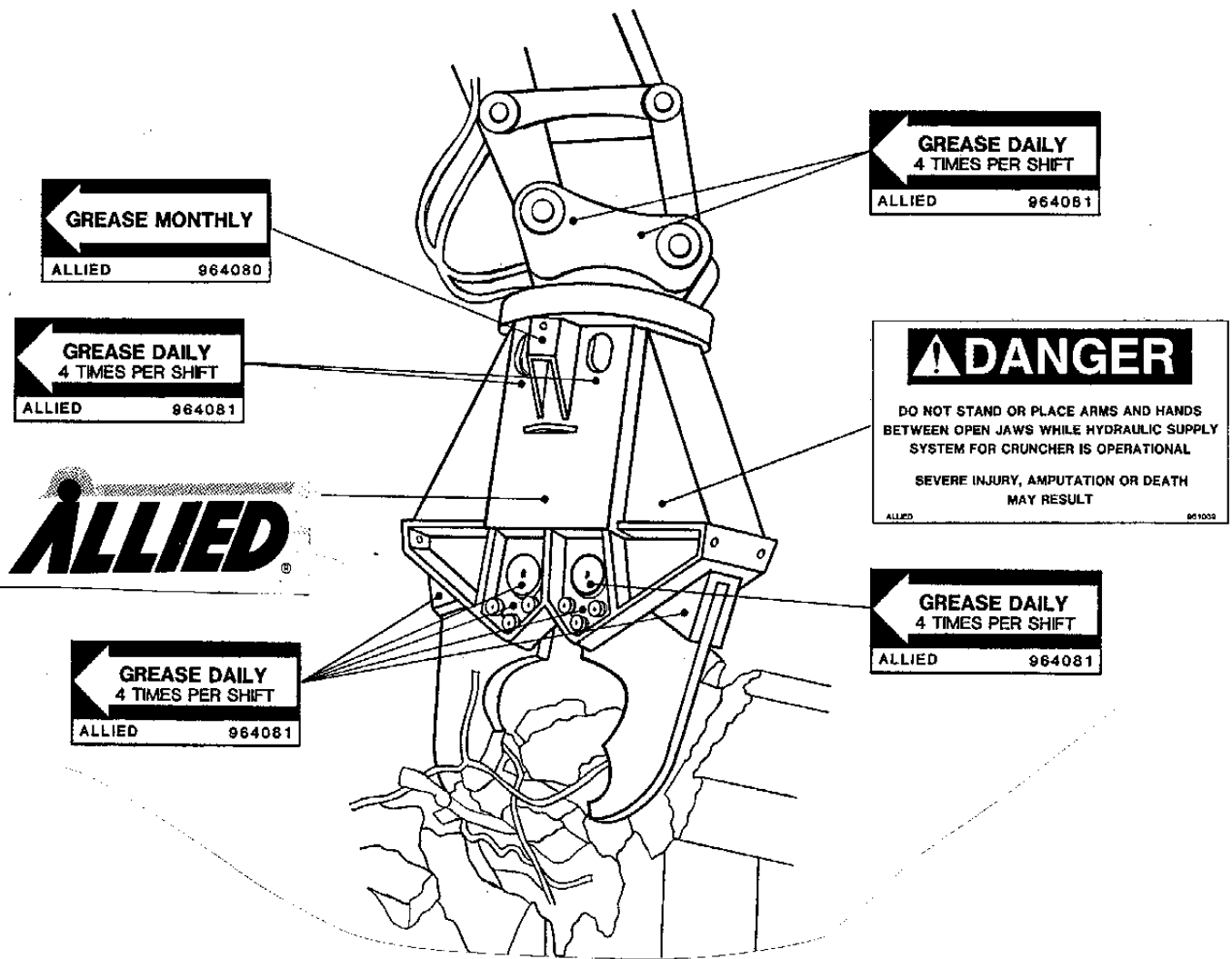



MODEL ACC 24 CRUNCHER SPARE PARTS DRAWING

PART NO. 960000

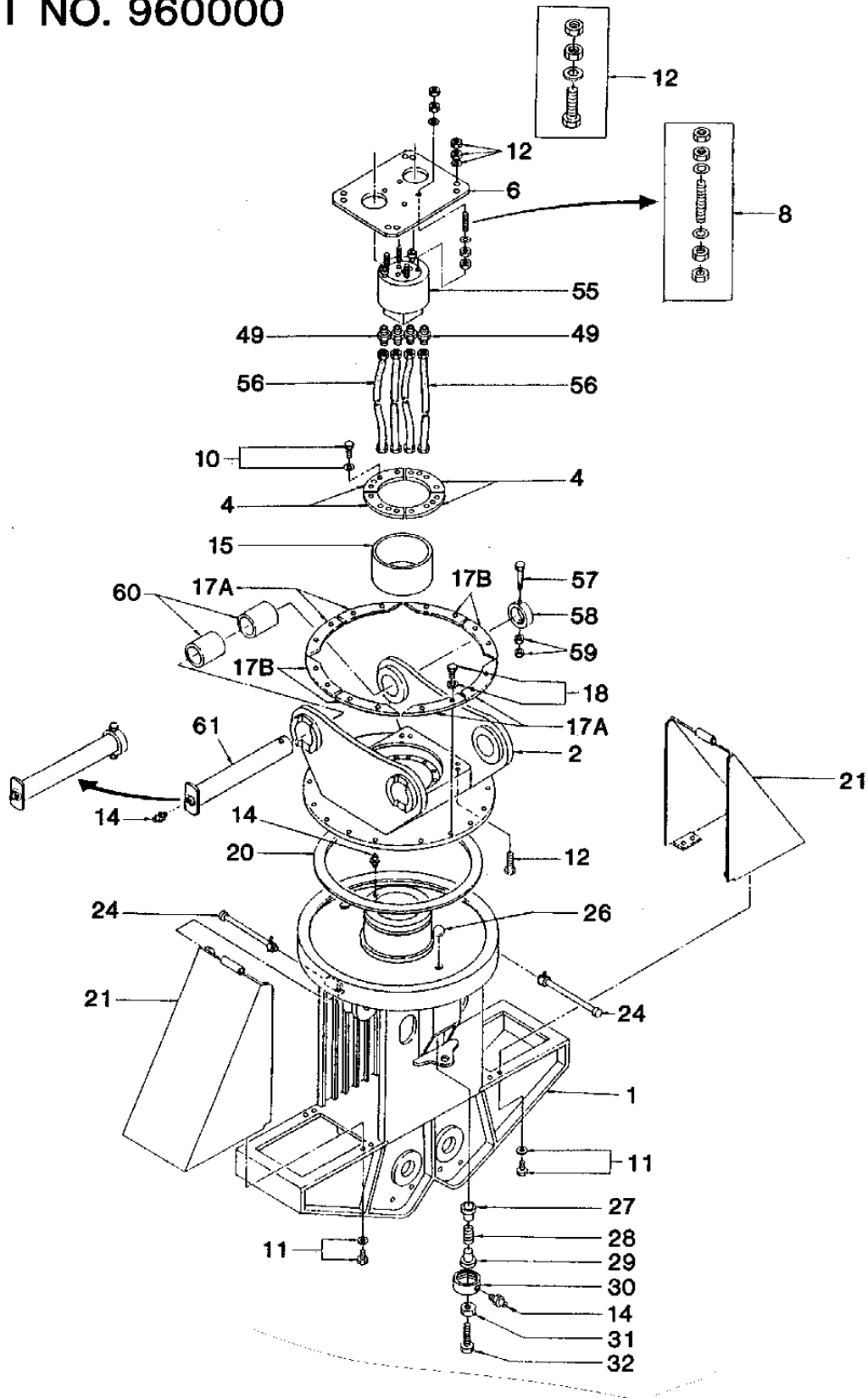

ALLIED HAS A POLICY OF CONTINUOUS PRODUCT IMPROVEMENT AND RESERVES THE RIGHT TO CHANGE SPECIFICATION OR DESIGN WITHOUT NOTICE.



MODEL ACC 24 CRUNCHER SPARE PARTS LIST

ITEM	QTY.	PART NO.	DESCRIPTION
1	1	960011	LOWER ROTATOR
2	1	960012	UPPER ROTATOR
4	3	960014	HOUSING SETTER
6	1	960016	SWIVEL JOINT COVER
8	4	960018	BOLT ASSEMBLY
10	12	960020	HOUSING SETTER BOLT
11	8	960021	CYLINDER COVER BOLT
12	8	960022	BOLT ASSEMBLY
13	1	960023	HOUSING
14	16	960024	GREASE NIPPLE
15	1	960025	RADIAL METAL
16	1	960026	THRUST METAL
17A	4	960101	SETTER
17B	4	960102	SETTER
18	16	960028	SETTER BOLT ASSEMBLY
20	1	960030	THRUST METAL
21	2	960031	CYLINDER COVER
24	2	960034	CYLINDER COVER PIN ASSEMBLY
27	2	964037	DETENT STOP SUPPORT
28	2	964038	DETENT STOP SPRING
29	2	964039	DETENT STOP GUIDE
30	2	964040	DETENT STOP CAP
31	2	964041	LOCK NUT
32	2	964042	ADJUST BOLT
49	2	960107	LONG NIPPLE
55	1	960065	SWIVEL JOINT
56	2	960109	LARGE HOSE
57	REFER TO INSTALLATION KIT FOR PARTS INFORMATION		BOLT
58			COLLAR
59			NUT
60			SLEEVE
61			MOUNTING PIN

ALLIED HAS A POLICY OF CONTINUOUS PRODUCT IMPROVEMENT AND RESERVES THE RIGHT TO CHANGE SPECIFICATION OR DESIGN WITHOUT NOTICE.



MODEL ACC 24 CRUNCHER SPARE PARTS DRAWING

PART NO. 960000

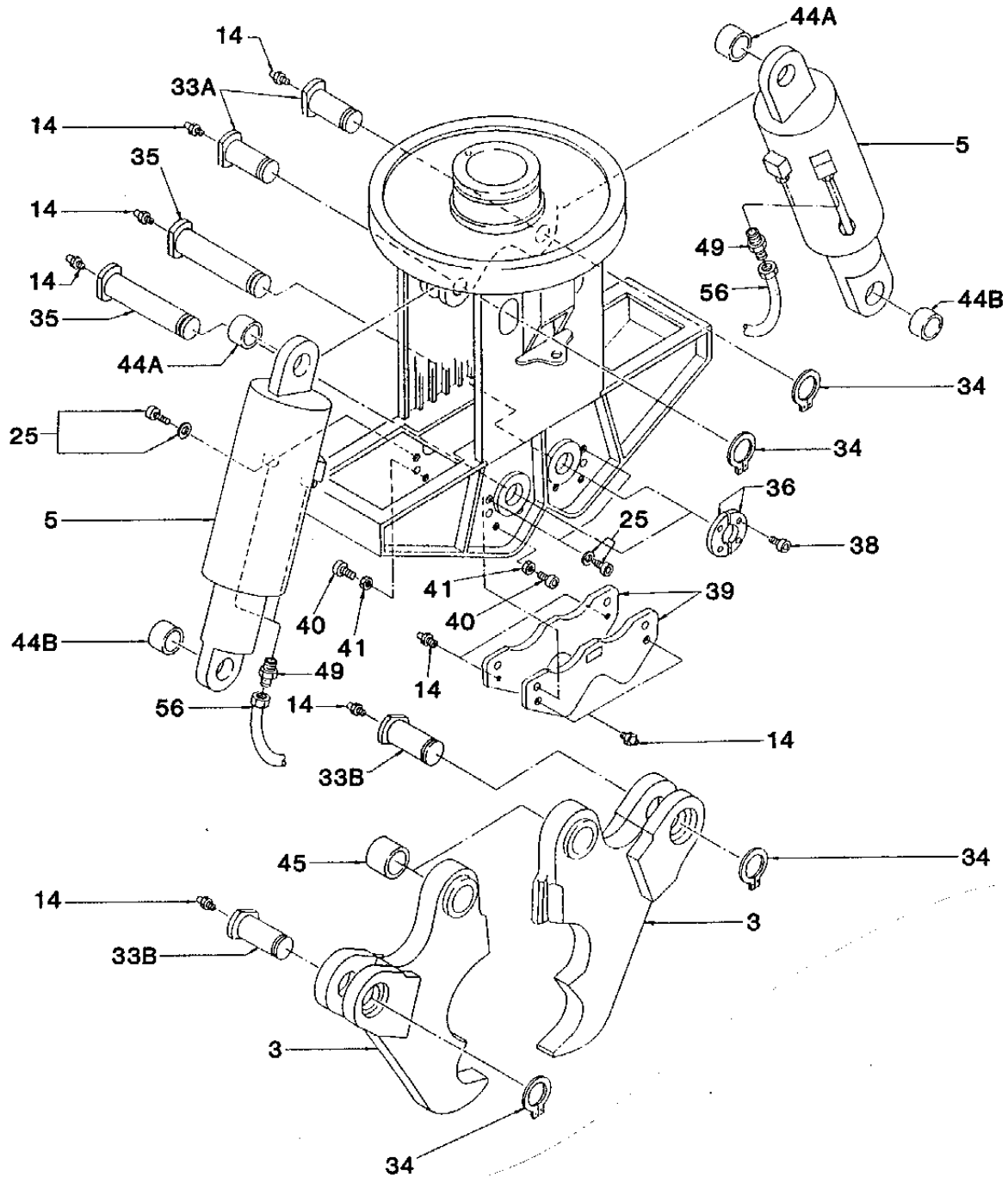

ALLIED HAS A POLICY OF CONTINUOUS PRODUCT IMPROVEMENT AND RESERVES THE RIGHT TO CHANGE SPECIFICATION OR DESIGN WITHOUT NOTICE.



MODEL ACC 24 CRUNCHER SPARE PARTS LIST

ITEM	QTY.	PART NO.	DESCRIPTION
3	2	960013	JAW
5	2	960015	CYLINDER
14	-	-----	GREASE NIPPLE
25	4	960035	PLATE HANGER BOLT
26	2	960036	DETENT STOP BALL
33A	2	960103	CYLINDER PIN
33B	2	960104	CYLINDER PIN
34	4	960044	FIXING SNAP RING
35	2	960045	JAW RETAINING PIN
36	4	960046	PIN STOPPER
37	2	960047	STOPPER RING
38	12	960048	BOLT
39	2	960049	JAW ADJUST PLATE
40	8	960050	JAW ADJUST BOLT
41	8	960051	JAW ADJUST LOCK NUT
44A	2	960105	BUSHING
44B	2	960106	BUSHING
45	2	960055	BUSHING
48	6	960058	NIPPLE
49	2	960107	LONG NIPPLE
56	-	-----	LARGE HOSE

ALLIED HAS A POLICY OF CONTINUOUS PRODUCT IMPROVEMENT AND RESERVES
THE RIGHT TO CHANGE SPECIFICATION OR DESIGN WITHOUT NOTICE.

HYDRAULIC COMPONENTS

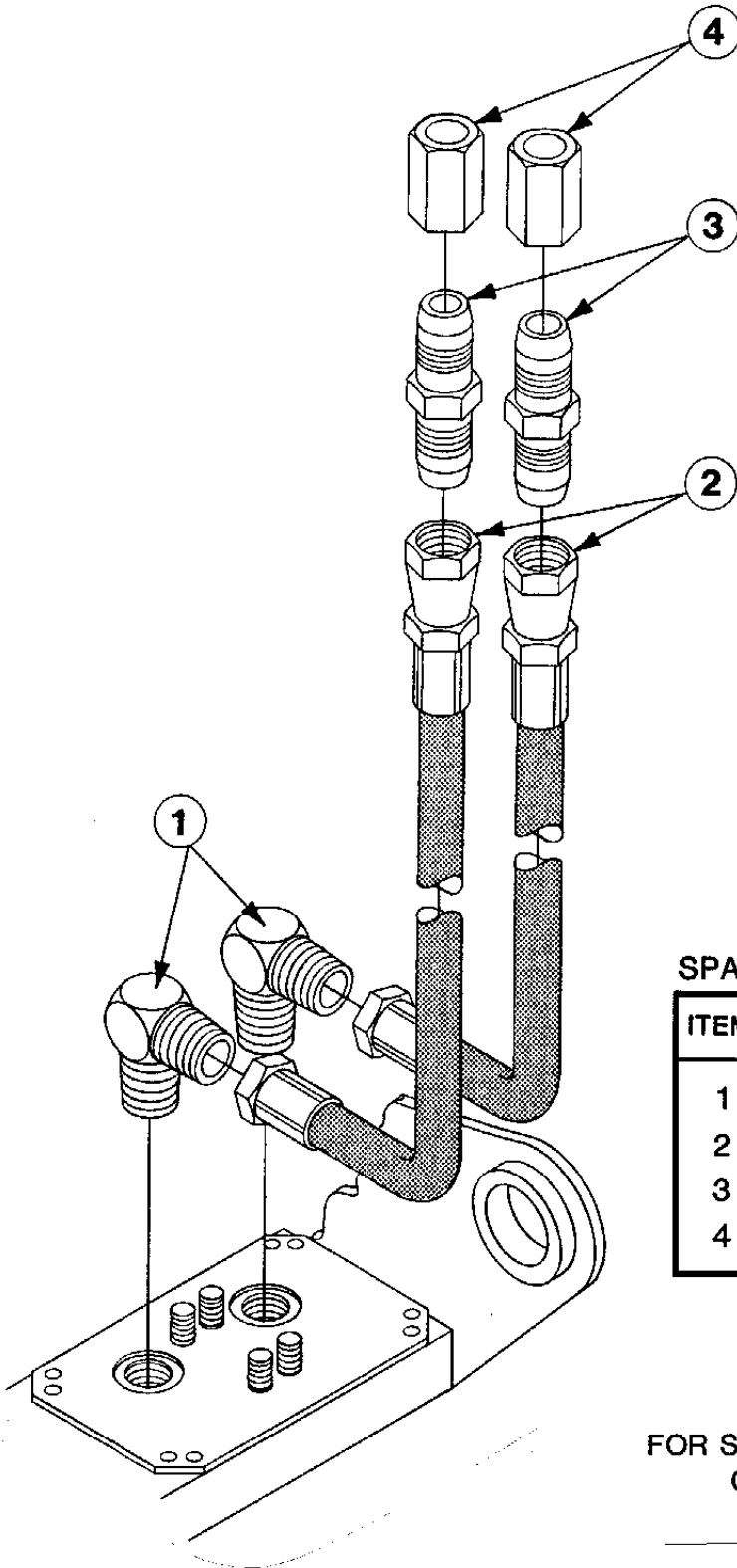

SPARE PARTS LIST

ITEM	QTY.	PART NO.	DESCRIPTION
1	2	960053	90 ELBOW
2	2	960120	HOSE ASSY.
3	2	656899	MALE UNION
4	2	814132	CAP

FOR SERVICE AND PARTS INFORMATION,
CONTACT ALLIED TECHNICAL
SERVICE DEPARTMENT

ALLIED HAS A POLICY OF CONTINUOUS PRODUCT IMPROVEMENT AND RESERVES
THE RIGHT TO CHANGE SPECIFICATION OR DESIGN WITHOUT NOTICE.



MODEL ACC 24 CRUNCHER SPARE PARTS DRAWING

SWIVEL JOINT PACKING ASSEMBLY

PART NO. 960072

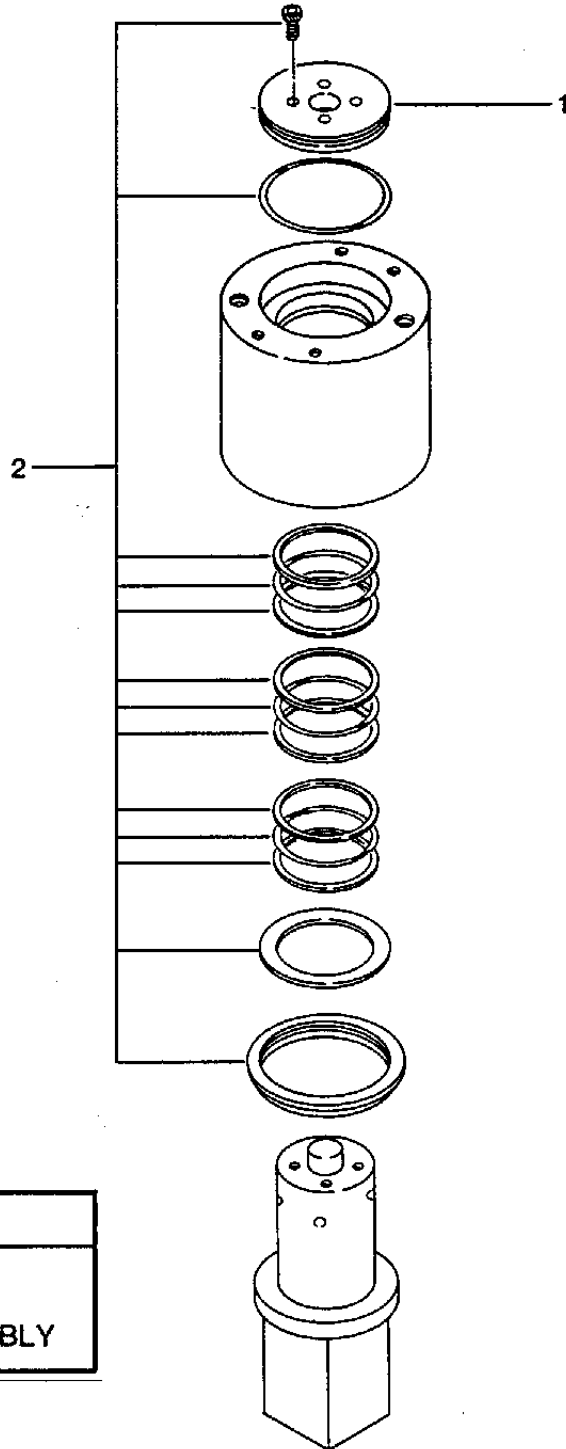

FOR SERVICE AND PARTS INFORMATION,
CONTACT ALLIED TECHNICAL
SERVICE DEPARTMENT

ITEM	QTY	PART NO	DESCRIPTION
1	1	960004	HEAD COVER
2	1	960005	PACKING ASSEMBLY

ALLIED HAS A POLICY OF CONTINUOUS PRODUCT IMPROVEMENT AND RESERVES
THE RIGHT TO CHANGE SPECIFICATION OR DESIGN WITHOUT NOTICE.



MODEL ACC 24 CRUNCHER SPARE PARTS DRAWING

CYLINDER PACKING ASSEMBLY PART NO. 960073

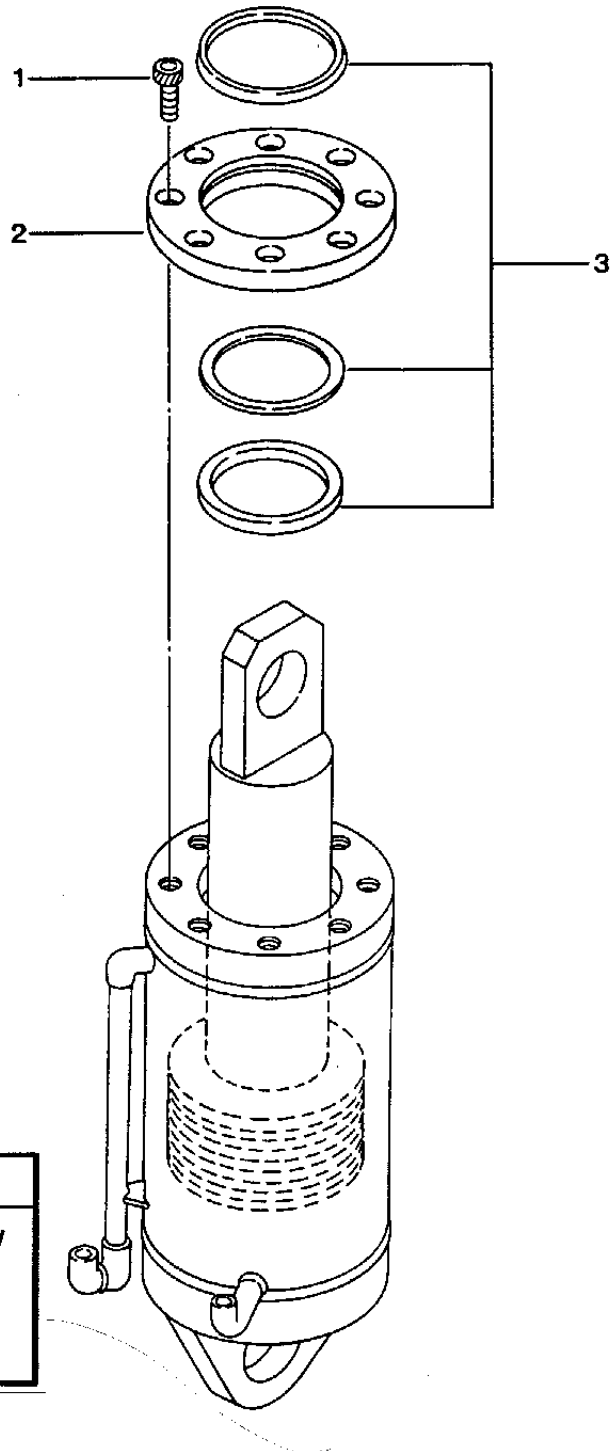

FOR SERVICE AND PARTS INFORMATION,
CONTACT ALLIED TECHNICAL
SERVICE DEPARTMENT

ITEM	QTY	PART NO	DESCRIPTION
1	8	960001	SOC HD CAP SCREW
2	1	960002	FLANGE
3	1	960003	PACKING ASSEMBLY

ALLIED HAS A POLICY OF CONTINUOUS PRODUCT IMPROVEMENT AND RESERVES
THE RIGHT TO CHANGE SPECIFICATION OR DESIGN WITHOUT NOTICE.



MODEL ACC 24 CRUNCHER
NOTES

A large, empty rectangular box with a thin black border, intended for handwritten notes.

CRUNCHER PRODUCT WARRANTY

BASE WARRANTY

ALLIED warrants its products to be well-made, durable and of good material and if within one hundred eighty (180) days from the date of delivery of such new product to the actual and original purchaser or renter, but no more than twelve (12) months from the date of shipment from **ALLIED'S** factory, any part except for wear items requiring daily or periodic inspection in accordance with the guidelines set forth in Allied's Concrete Cruncher Operating and Maintenance Manual which are covered by the **LIMITED WARRANTY**, shall fail by reason of defective material or poor workmanship, **ALLIED** will at its option, repair or furnish such part free of charge under the conditions listed in **WARRANTY LIMITATIONS**, **ALLIED'S WARRANTY LABOR ALLOWANCE POLICY IS WITH THE DEALER**. All inquiries on the **WARRANTY LABOR ALLOWANCE** should be directed to the Allied Authorized Sales and Service Dealer.

LIMITED WARRANTY

The wear items requiring daily or periodic inspection are covered by the **LIMITED WARRANTY** for a period of thirty (30) days if inspected and maintained in accordance with the guidelines set forth in Allied's Concrete Cruncher Operating and Maintenance Manual. **ALLIED** reserves the full right to determine if and to what extent warranty adjustments may be made for damage or breakage of these items. **ALLIED IS NOT RESPONSIBLE FOR LABOR OR ANY OTHER INCIDENTAL OR CONSEQUENTIAL ITEM REQUIRED TO MAKE THE REPAIR.**

EXTENDED WARRANTY

The **EXTENDED WARRANTY** covers failure of the bracket housing, arm box housing and arm assembly housing, which results under normal use and service, from defects in workmanship or material in the part. The coverage begins with the expiration of the **BASE WARRANTY** and ends one (1) year from the date of delivery. New or **ALLIED** approved rebuilt (bracket housing, arm box housing or arm assembly housing) may be used in making the repair. **ALLIED IS NOT RESPONSIBLE FOR LABOR OR ANY OTHER INCIDENTAL OR CONSEQUENTIAL ITEM REQUIRED TO MAKE THE REPAIR.** **ALLIED** is not responsible for the replacement of parts damaged due to the bracket housing, arm box housing, and arm assembly housing failure or repair.

WARRANTY LIMITATIONS

For warrantable failures, **ALLIED** will, at its option, repair or furnish such part free of charge, F.O.B. factory where manufactured (or other place designated by **ALLIED**); provided, however, that the defective part or sufficient evidence of such defect in the part be delivered to its factory in the United States where manufactured (or other place designated by **ALLIED**), transportation prepaid. Such parts or such evidence must clearly show that the failure was due to poor workmanship or defective material and not due will be accepted by **ALLIED** unless the proper filled out claim form is submitted and received by **ALLIED** within thirty (30) days of the date of discovery of the defect or within fifteen (15) days of the date of repair. Breakage of damage resulting from installation or operation or use not in accordance with **ALLIED'S** published installation and operating instructions are not covered by any warranty. Operation or use beyond capacities, substitution or interchanging of parts or any alterations not approved by **ALLIED** shall void this warranty.

ALLIED'S responsibility and warranty applies only when this equipment is operated and used in accordance with (1) its published instructions and (2) pursuant to the terms, conditions and restrictions of any local, state, dominion or federal laws, ordinances and regulations. The purchaser, user or renter assumes the responsibility to familiarize himself with such published capacities, instructions, terms and conditions as set forth above. **ALLIED'S** warranty is voided if the serial number is removed or altered in any way.

The original purchaser, user or renter is responsible for "downtime" expenses and all business costs and losses resulting from a warrantable failure.

DISCLAIMER

THESE WARRANTIES AND THE COMPANY'S OBLIGATIONS THEREUNDER ARE IN LIEU OF ALL WARRANTIES, EXPRESS OR IMPLIED, INCLUDING WITHOUT LIMITATION, THE IMPLIED WARRANTIES OF MERCHANTABILITY AND FITNESS FOR PARTICULAR PURPOSE, ALL OTHER REPRESENTATIONS TO THE ORIGINAL PURCHASER, USER OR RENTER AND ALL OTHER OBLIGATIONS OR LIABILITIES, INCLUDING LIABILITY FOR INCIDENTAL AND CONSEQUENTIAL DAMAGES ON THE PART OF THE COMPANY OR THE SELLER WITH RESPECT TO THE SALE OR USE OF THE MACHINE.

No person is authorized to give any other warranties or to assume any other liability on the Company's behalf unless made or assumed in writing by the Company, and no person is authorized to give any warranties or to assume any liabilities on the seller's behalf unless made or assumed in writing by the seller.

ALLIED specifically disclaims any responsibility for any damages of any kind or description, whether to property or person, in any way connected with or arising out of the use of said product.



5800 HARPER ROAD, SOLON, OHIO 44139
(216) 248-2600 TELEFAX (216) 248-1915

©1989 ALLIED Solon, Ohio USA

Form No. ACC191 1M