



PARTS MANUAL

Manual Part Number 100083



MODEL AR 48 HAMMER

Allied Model AR 48 Hammer
Document Change Notice

| <u>Date</u> | <u>Page</u> | <u>Change</u> |
|-------------|------------------|------------------------------|
| 8-31-01 | 1 | Update Specs |
| 8-31-01 | 9, 15, 19, 21 | Parts Lists |
| 8-31-01 | 14, 18, 20 | Art |
| 3-26-02 | 1 and throughout | Specs and added abbr. |
| 3-26-02 | 9,11,13 | Parts Lists |
| 3-26-02 | 10,12 | Art |
| 2-25-03 | throughout | added drawings |
| 8-19-03 | 1,7,19 | Decals, Parts Lists, Specs |
| 1-8-08 | 7,9 | Revise Seal |
| 1-8-08 | 7 | Add Nitrogen Fill Valve Note |

Table of Contents

| | |
|--|-----------|
| Main Components | 0 |
| 1.0 PRODUCT I.D., TERMINOLOGY, AND SPECIFICATIONS | 1 |
| 2.0 HAMMER IDENTIFICATION | 1 |
| 3.0 EQUIPMENT SPECIFICATIONS | 1 |
| 4.0 DIMENSIONS | 2 |
| Dimension Drawing - Mini-Excavator Configuration(XSF) | 3 |
| Dimension Drawing - 2-Position Skid Steer Configuration (SSU-2) | 5 |
| Parts Diagram | 6 |
| Seal Kit | 8 |
| Mini-Excavator Configuration | 10 |
| Skid Steer Configuration | 12 |
| Low Pressure Nitrogen Prechargeing Kit | 14 |
| Demolition Tools | 16 |
| Decal Identification | 18 |
| Decal Location - Mini-Excavator Configuration (XSF) | 20 |
| Decal Location - 2-Position Skid Steer Configuration (SSU-2) | 22 |

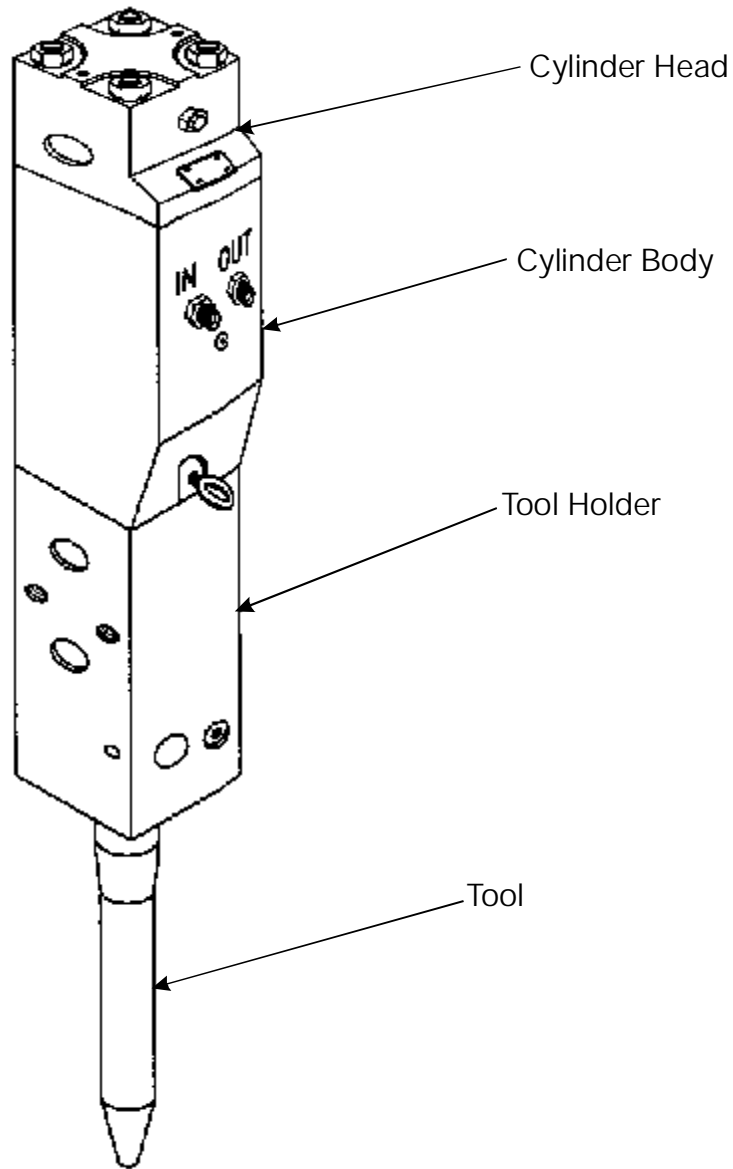

Main Components

1.0 PRODUCT I.D., TERMINOLOGY AND SPECIFICATIONS

Prior to ordering or replacing parts, make sure the hammer matches the model and configuration covered in this manual. Refer to paragraph 2.0 Hammer Identification. For quick reference, the technical specifications are included in paragraph 3.0 Equipment Specifications.

2.0 HAMMER IDENTIFICATION

The hammer model and serial numbers are stamped on the I.D. Tag located at the top of the right side plates. This I.D. Tag is shown on the Decal Location Drawing.

3.0 EQUIPMENT SPECIFICATIONS

| Table 3-1. Technical Specifications Hammer Model AR 48 | | |
|---|----------------------------------|---|
| Frequency Range | Blows per Minute | 700 - 1500 |
| Hydraulic Flow | g.p.m. (lpm) | 4 - 9 (15 - 35) |
| Hydraulic Operating Pressure | psi (bar) | 1300 - 1750 (90 - 120) |
| Hydraulic Relief Pressure | psi (bar) | 2050 (141) |
| Pressure in Nitrogen Precharge Chamber | psi (bar) psi (bar) | 185 (12.8) at 70° F (21° C) 215 (15.0) at 150° F (65° C) |
| Weight* Excavator Skid Steer | lbs. (kg) | 320 (145) 600 (272) |
| Working Length** Excavator Skid Steer | in. (mm) | 46.2 (1174)* 42.0 (1066) |
| Demolition Tool Diameter Working Length | Standard in. (mm) in. (mm) | Conical 1.89 (48) 12 (305) |
| Carrier Weight Class Excavator Skid Steer | 1000 lbs. (kg) | 4,000 - 8,000 (1,814 - 3,629) 3,000 - 6000 (1,300 - 2,700) |

*Dimension D on dimension diagram.

**Includes side plates and tool.

Serial Number (owner record upon receipt)

S/N

4.0 DIMENSIONS

The dimensions listed in Table 4-1 below are illustrated in the drawing on the next page. Each dimension is indicated by a letter on the drawing. Table 4-1 lists these letters, each dimension and an explanation of the dimension.

| Table 4-1. Dimensions of AR 48 Hammer - Mini-Excavator Configuration (XSF) | | |
|--|-----------------------|--|
| Letter | Dimension in. (mm) | Description |
| A | 48.7 (1225) | Hammer length |
| B | 9.44 (240) | Hammer width |
| C | 12 (305) | Tool length |
| D | 46.2 (1174) | Hammer working length - stick pin to tool tip. |
| E | 6.69 (170) | Mounting width |
| F | 13.4 (340) | Hammer depth |
| G | 7.00 (178) | Stick pin to link pin length |
| H | 1.89 (48) | Tool diameter |

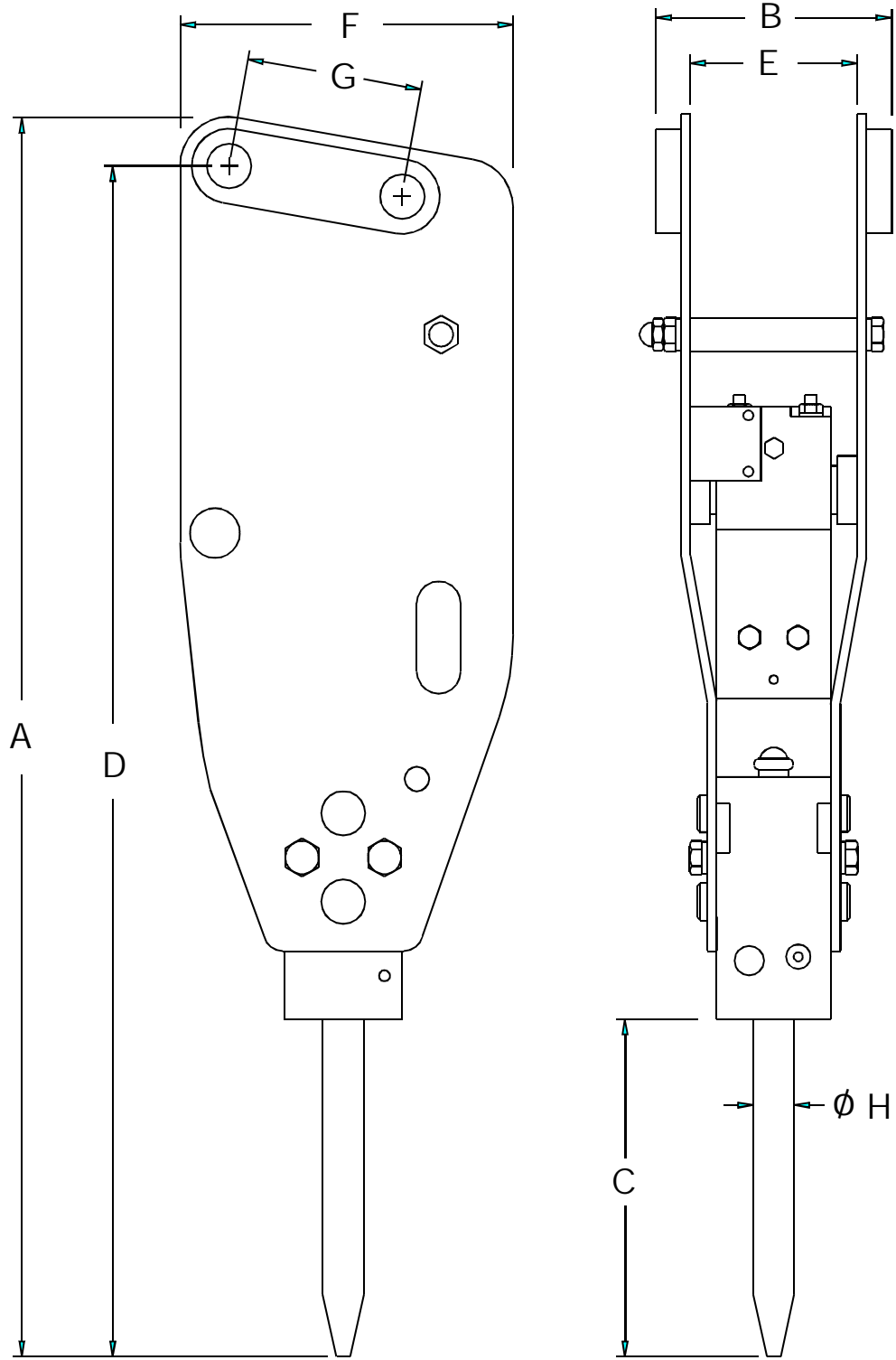

Dimension Drawing - Mini-Excavator Configuration (XSF)

The dimensions listed in Table 4-2 below are illustrated in the drawing on the next page. Each dimension is indicated by a letter on the drawing. Table 4-2 lists these letters, each dimension and an explanation of the dimension.

| Table 4-2. Dimensions of AR 48 Hammer - 2-Position Universal Skid Steer Configuration (SSU-2) | | |
|---|-----------------------|-----------------------|
| Letter | Dimension in. (mm) | Description |
| A | 46.2 (1184) | Hammer length |
| B | 48.5 (1232) | Hammer width |
| C | 12 (305) | Tool length |
| D | 42.0 (1066) | Hammer working length |
| E | 39° | Hammer rotation angle |
| F | 20.0 (508) | Hammer depth |
| G | 1.89 (48) | Tool diameter |

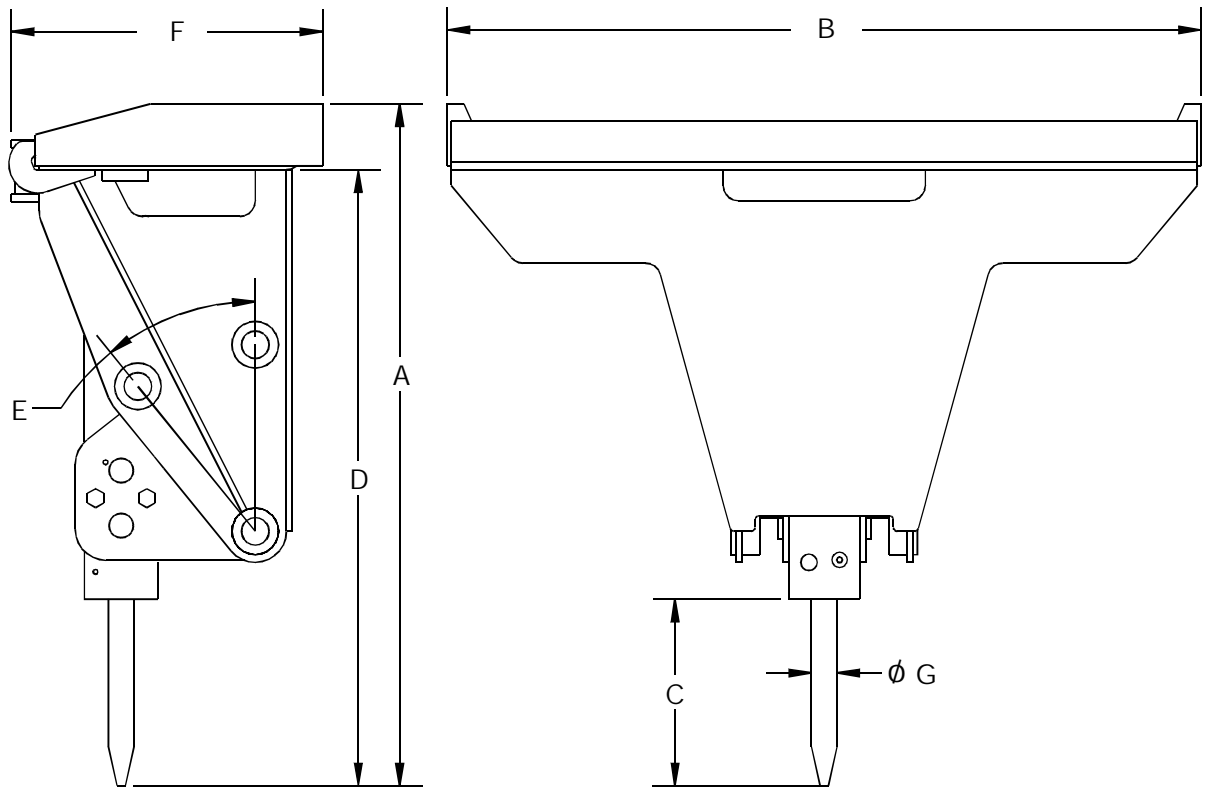

Dimension Drawing - 2-Position Universal Skid Steer Configuration (SSU-2)

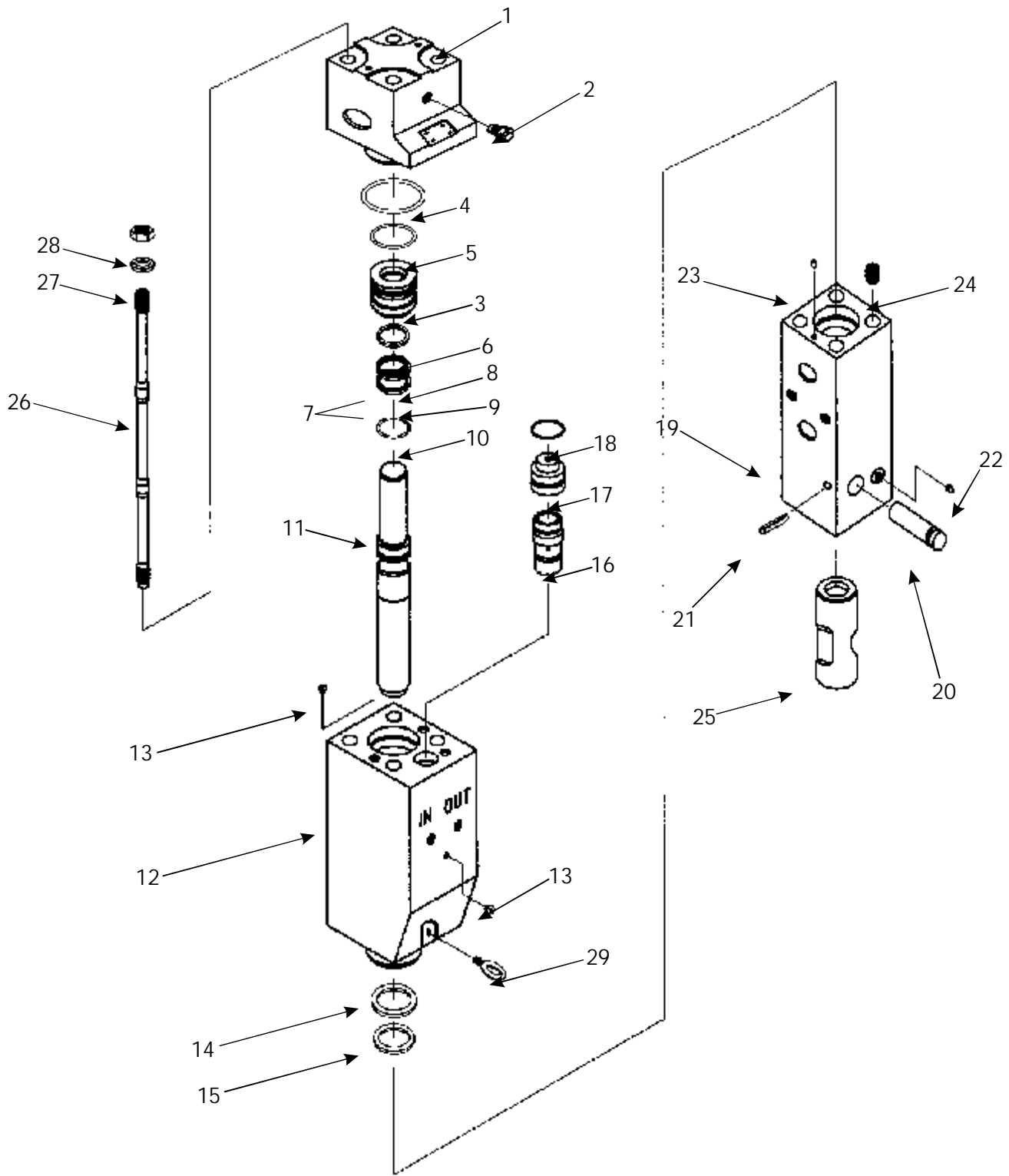

AR 48 Parts Diagram

| AR 48 Parts | | | | |
|-------------|------|----------|--|--|
| ITEM ONLY | QTY. | PART NO. | DESCRIPTION | |
| 1 | 1 | 100091 | Cylinder Head | |
| 2 | 1 | 100092 | Nitrogen Fill Valve | |
| 3 | 1 | 100093 | Piston Bushing | |
| * 4 | 1 | 100107 | O-Ring | |
| * 5 | 1 | 676203 | O-Ring | |
| * 6 | 1 | 100108 | Seal | |
| * 7 | 2 | 100117 | Step Seal Package (Includes Items 8 & 9) | |
| * 8 | 1 | 100113 | Step Seal | |
| * 9 | 1 | 100114 | O-Ring | |
| * 10 | 1 | 676203 | O-Ring | |
| 11 | 1 | 100094 | Piston | |
| 12 | 1 | 100095 | Cylinder Body | |
| 13 | 4 | 676159 | Threaded Plug | |
| * 14 | 1 | 100110 | Seal | |
| * 15 | 1 | 100111 | Wiper | |
| 16 | 1 | 100246 | Regulator Spool | |
| 17 | 1 | 100247 | Regulator Cover | |
| * 18 | 1 | 676206 | O-Ring | |
| 19 | 1 | 100102 | Tool Holder | |
| ** 20 | 1 | 100104 | Retainer Pin | |
| ** 21 | 1 | 670034 | Roll Pin | |
| 22 | 1 | 816675 | Lubrication Nipple | |
| 23 | 1 | 676183 | Index Pin | |
| 24 | 4 | 100105 | Thread Insert | |
| ** 25 | 1 | 100103 | Tool Bushing | |
| 26 | 4 | 100098 | Tension Bolt | |
| 27 | 4 | 100100 | Tension Bolt Washer | |
| 28 | 4 | 100099 | Tension Bolt Nut | |
| 29 | 1 | 100101 | Lifting Eyebolt | |

For S/N 00026 & above: Nitrogen Fill Valve 100092 replaced by Bushing 570242 and Fill Valve 657257

*** Included in Seal Kit**

**** Included in Rebuild Kit. Rebuild Kit PN 101350, includes items 20, 21, 25 and Seal Kit**

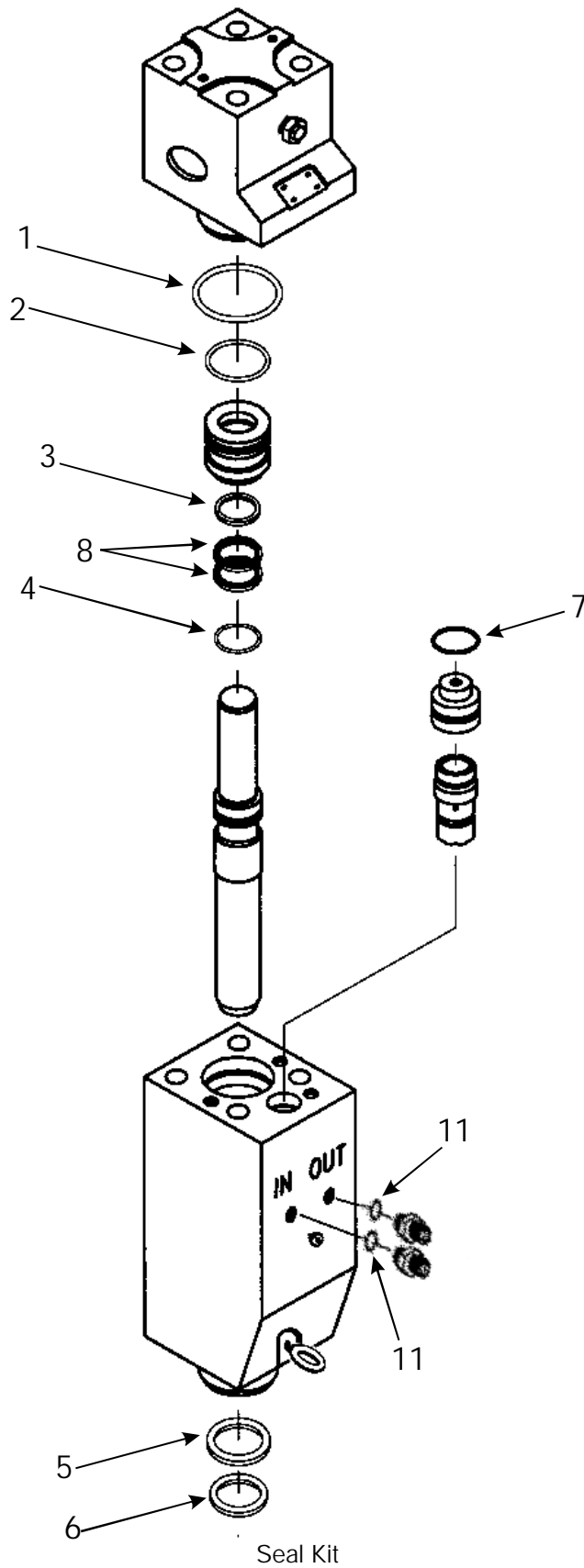

| Seal Kit Part No. 100116 | | | |
|-----------------------------|------|----------|--|
| ITEM ONLY | QTY. | PART NO. | DESCRIPTION |
| 1 | 1 | 100107 | O-Ring |
| 2 | 1 | 676203 | O-Ring |
| 3 | 1 | 100108 | Seal |
| 4 | 1 | 676203 | O-Ring |
| 5 | 1 | 100110 | Seal |
| 6 | 1 | 100111 | Wiper |
| 7 | 1 | 676206 | O-Ring |
| 8 | 2 | 100117 | Step Seal Package (Includes Items 9 & 10) |
| 9 | 1 | 100113 | Step Seal |
| 10 | 1 | 100114 | O-Ring |
| 11 | 2 | 100097 | O-Ring (not required with bonded seal adapter) |

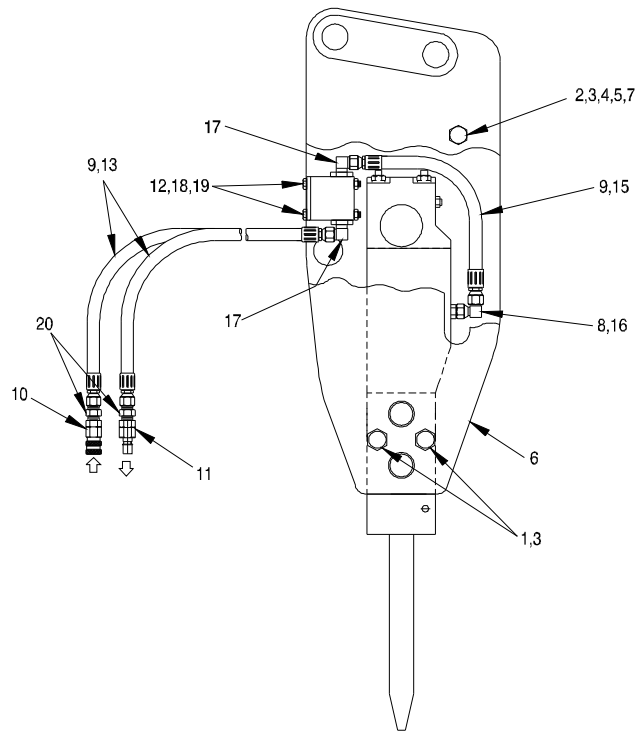
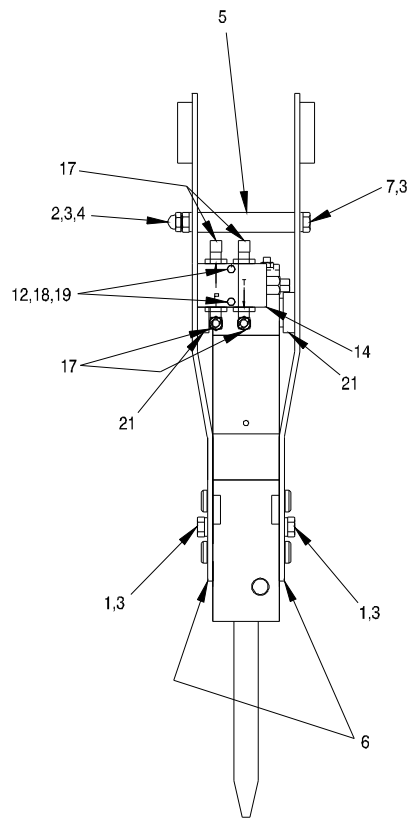

Mini-Excavator Configuration (XSF)

| Mini-Excavator Configuration (XSF) Part Number 100085 | | | |
|--|------|----------|---------------------------------------|
| ITEM ONLY | QTY. | PART NO. | DESCRIPTION |
| 1 | 4 | 100086 | Hex Head Cap Screw |
| 2 | 1 | 100087 | Hex Nut |
| 3 | 6 | 100088 | Lockwasher |
| 4 | 1 | 100089 | Acorn Nut |
| 5 | 1 | 100090 | Spacer, Mounting Plate |
| 6 | 1 | 658568 | Side Plates (Set) |
| 7 | 1 | 667458 | Hex Head Cap Screw |
| 8 | 2 | 865313 | Adapter with Seal |
| 9 | 1 | 667472 | Hose Protector (40 in.) (not shown) |
| 10 | 1 | 670007 | Standard Q.D. Coupling Socket |
| 11 | 1 | 670008 | Standard Q.D. Coupling Plug |
| 12 | 2 | 676799 | Hex Head Cap Screw |
| 13 | 2 | 865308 | Hose Assembly |
| 14 | 1 | 676853 | Flow Control Valve |
| | 1 | 676800 | Seal Kit - Relief Valve |
| | 1 | 676801 | Seal Kit - Differential Sensing Valve |
| 15 | 2 | 814118 | Hose Assembly |
| 16 | 2 | 814146 | 90° Swivel Elbow |
| 17 | 4 | 883655 | 90° Elbow |
| 18 | 2 | 902523 | Elastic Stop Nut |
| 19 | 2 | 563642 | Flatwasher |
| 20 | 2 | 653349 | Adapter |
| 21 | 2 | 100674 | Wear Pad |

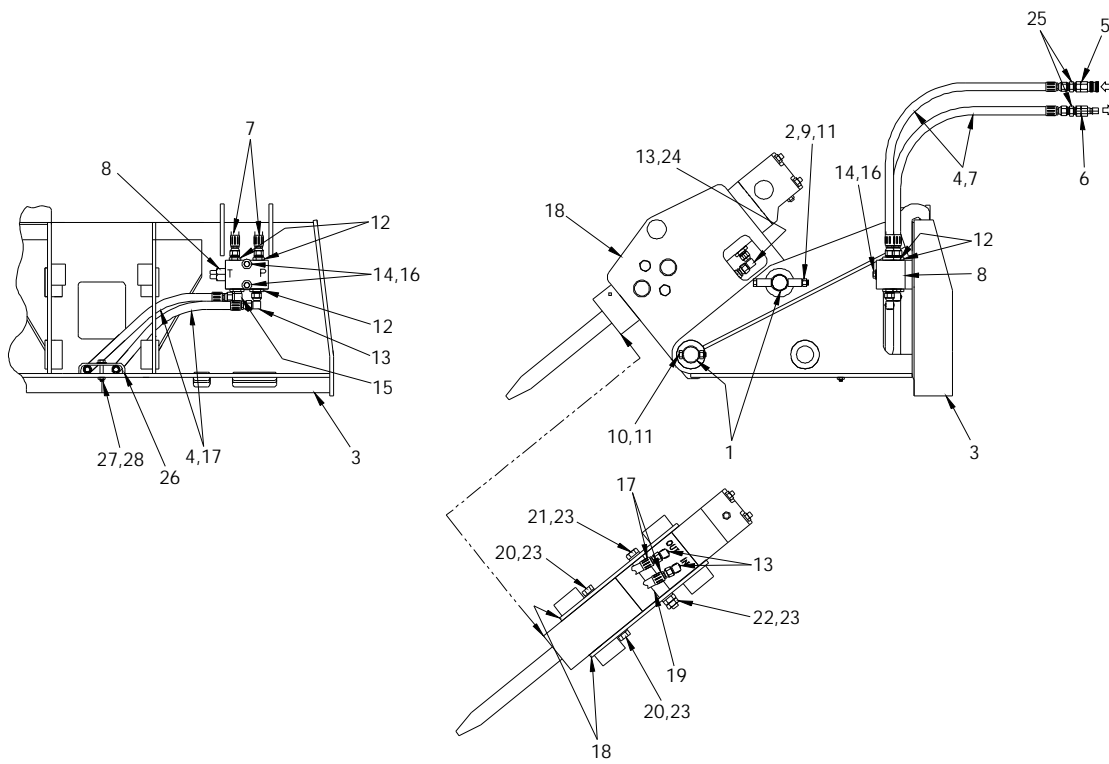

2-Position Universal Skid Steer Configuration (SSU-2)

| 2-Position Universal Skid Steer Configuration (SSU-2) Part Number 100298 | | | |
|---|------|----------|---------------------------------------|
| ITEM ONLY | QTY. | PART NO. | DESCRIPTION |
| 1 | 2 | 100192 | Pin |
| 2 | 1 | 563356 | Hex Head Cap Screw |
| 3 | 1 | 658660 | 2-position Mounting Bracket |
| 4 | 1 | 667472 | Hose Protector (52 in.) (not shown) |
| 5 | 1 | 670007 | Standard Q.D. Coupling Socket |
| 6 | 1 | 670008 | Standard Q.D. Coupling Plug |
| 7 | 2 | 865308 | Hose Assembly |
| 8 | 1 | 676853 | Flow Control Valve |
| | 1 | 676800 | Seal Kit - Relief Valve |
| | 1 | 676801 | Seal Kit - Differential Sensing Valve |
| 9 | 2 | 676939 | Nylon Sleeve |
| 10 | 3 | 708511 | Hex Head Cap Screw |
| 11 | 4 | 813289 | Elastic Nut |
| 12 | 3 | 814133 | Adapter |
| 13 | 3 | 814146 | 90° Swivel Elbow |
| 14 | 2 | 814213 | Hex Head Cap Screw |
| 15 | 1 | 883655 | 90° Elbow |
| 16 | 2 | 903713 | Flatwasher |
| 17 | 2 | 100621 | Hose Assembly |
| 18 | 1 | 658555 | Side Plates (Set) |
| 19 | 1 | 100551 | Spacer |
| 20 | 4 | 100086 | Metric Hex Head Cap Screw |
| 21 | 1 | 100552 | Metric Hex Head Cap Screw |
| 22 | 2 | 100087 | Metric Hex Nut |
| 23 | 4 | 100088 | Metric Lock Washer |
| 24 | 2 | 865313 | Adapter with Seal |
| 25 | 2 | 653349 | Adapter |
| 26 | 1 | 100439 | Hose Clamp |
| 27 | 1 | 759808 | Elastic Stop Nut |
| 28 | 1 | 865467 | Hex Head Cap Screw |

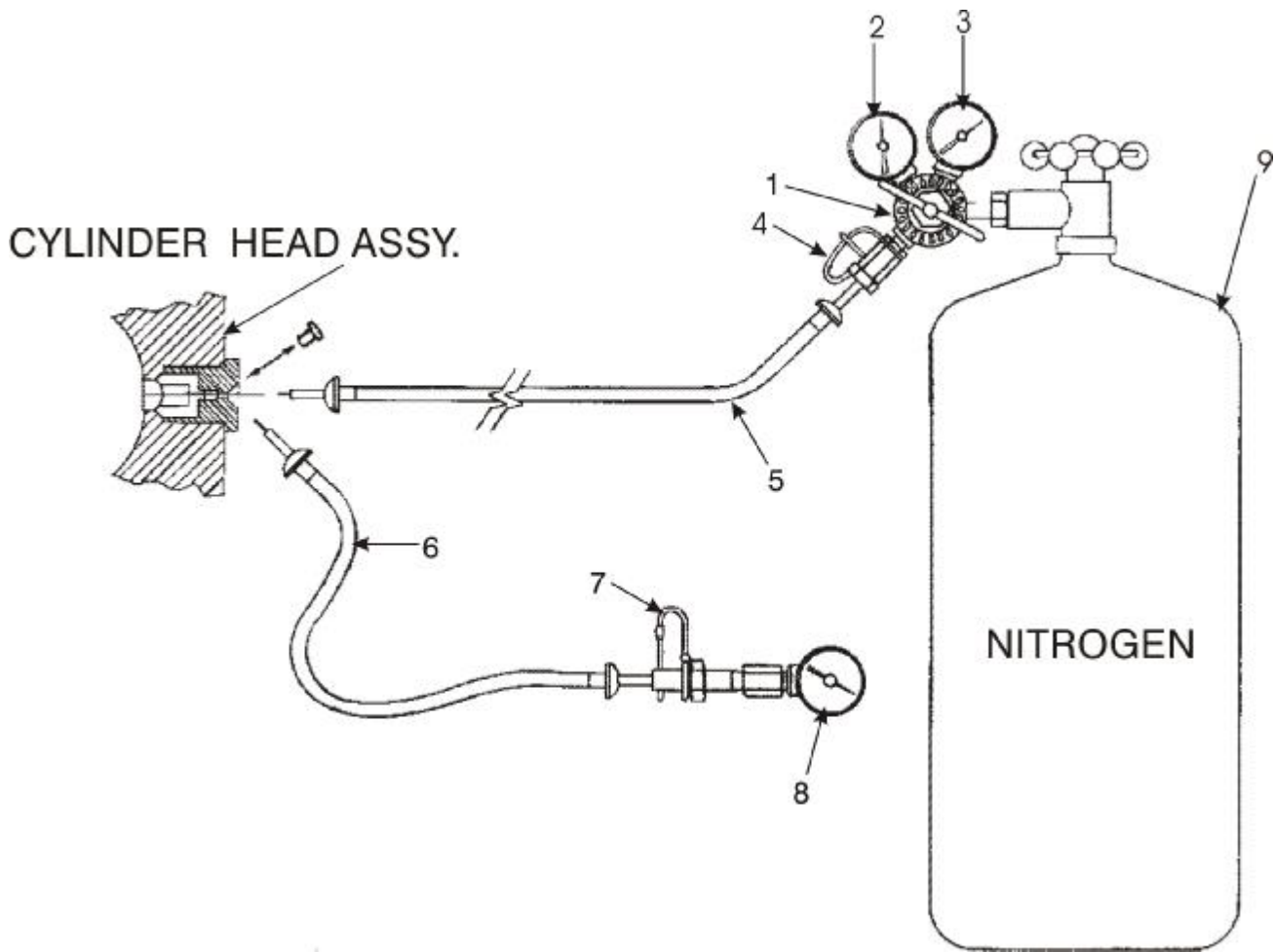

| Low Pressure Nitrogen Precharging Kit For Precharge Chamber Part Number 657341 | | | |
|---|------|----------|---|
| ITEM ONLY | QTY. | PART NO. | DESCRIPTION |
| 1 | 1 | 657493 | Pressure Regulator (Includes Items 2 and 3) |
| 2 | 1 | 657495 | 0-400 PSI Pressure Gauge |
| 3 | 1 | 657496 | 0-4000 PSI Pressure Gauge |
| 4 | 1 | 657494 | Hose Adapter |
| 5 | 1 | 657481 | Fill Hose |
| 6 | 1 | 657486 | Test Hose |
| 7 | 1 | 657487 | Test Hose Adaptor |
| 8 | 1 | 657497 | Test Gauge |
| 9 | 1 | — | Nitrogen Tank (Not furnished by Allied) |

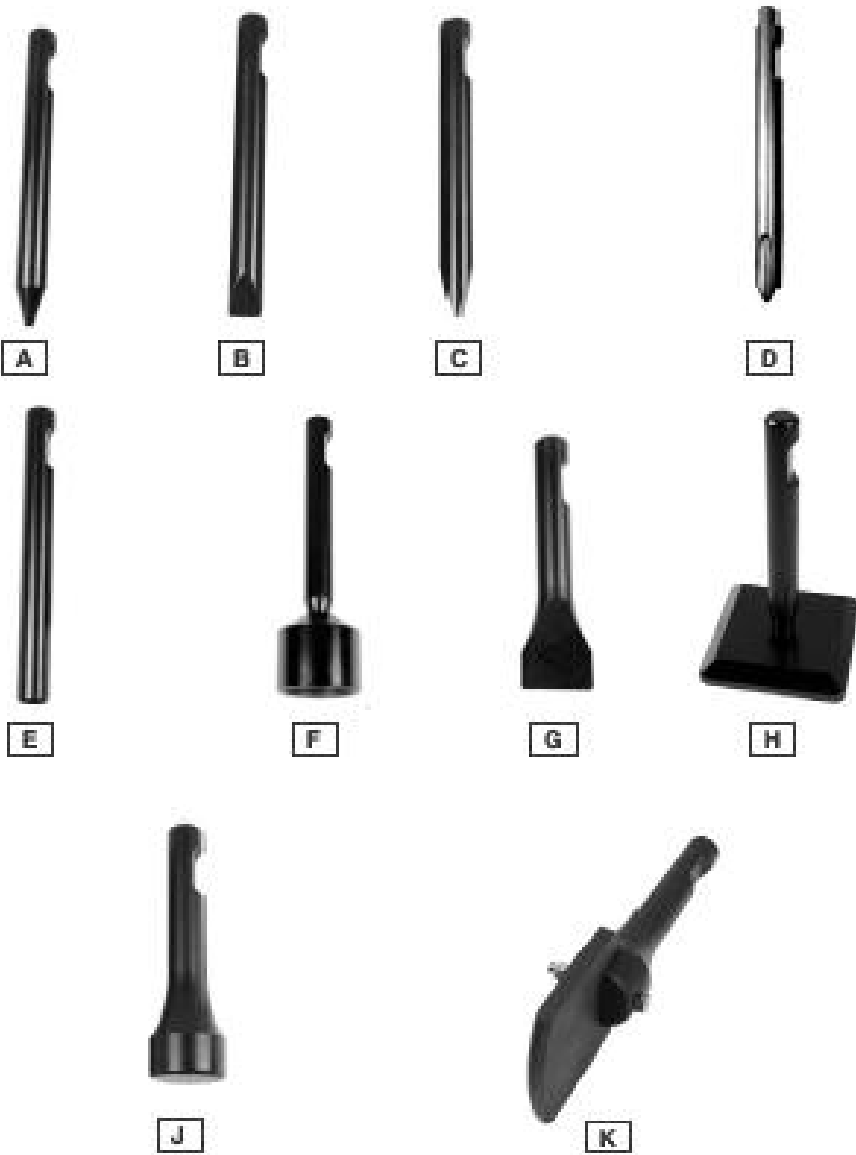

Demolition Tools

| Demolition Tools | | | | |
|------------------|--------------------|----------------|-----------------|----------|
| | Designation | Working Length | Weight | Part No. |
| A | Conical point | 12 in. (305mm) | 11lbs. (5.0kg) | 676915* |
| B | Cross-cut wedge | 12 in. (305mm) | 12 lbs. (5.4kg) | 676807 |
| C | Inline Chisel | 12 in. (305mm) | 12 lbs. (5.4kg) | 100486 |
| D | Relieved Moil | 12 in. (305mm) | 13 lbs. (5.9kg) | 100487 |
| E | Blunt | 12 in. (305mm) | 14 lbs. (6.4kg) | 100583 |
| F | Post Driver | 17 in. (432mm) | 47 lbs. (kg) | 101017 |
| G | Frost Cutter 5.50" | 12 in. (305mm) | 15 lbs. (kg) | 100994 |
| H | Soil Tamper | 13 in. (330mm) | 53 lbs. (kg) | 100970 |
| J | Bell End 5.50" | 12 in. (305mm) | 24 lbs. (kg) | 100993 |
| K | Asphalt Cutter | 20 in. (508mm) | 36 lbs. (kg) | 100971 |

***Standard Tool supplied with Model AR 48.**

Allied Chisel Paste

NOTE: The use of Allied Chisel Paste will extend bushing and tool life of the hammers. It is specially formulated with copper/graphite ingredients that distinguish it from other lubricants on the market. Allied Chisel Paste provides superior and longer lasting lubrication properties over a wide range of operating temperatures. Ordering information:

| | |
|-------------------------------------|-----------------|
| Case: 12 Tubes (16 oz.) Manual Lube | Part No. 100057 |
| Case: 36 Tubes (16 oz.) Manual Lube | Part No. 100058 |
| Keg (35 lbs) Manual Lube | Part No. 676698 |
| Keg (120 lbs.) manual Lube | Part No. 679968 |

DECAL IDENTIFICATION



The LIFT POINT decal identifies the location of the recommended lifting points of the Hy-Ram.



The CAUTION MAXIMUM PRESSURE decal gives the maximum oil pressure for this model Hy-Ram.



The LUBRICATION decal identifies the location and frequency of required lubrication.



The hammer energy is measured in accordance with the CIMA tool energy rating method.



The STAY CLEAR decal indicates that personnel and bystanders are to maintain a safe distance from the Hy-Ram during operation.

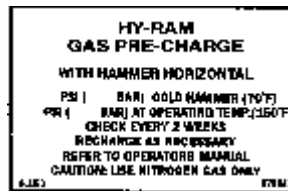

The GAS PRE-CHARGE decal has pressure settings for the Hy-Ram nitrogen precharge chamber for cold hammer and operating temperature.



The READ INSTRUCTION decal indicates that it is important for the operator to read the manual prior to transporting, installing, operating, or servicing the Hy-Ram.



The DANGER TOOL SHARPENING decal states that the operator must be protected and that the tool cannot be welded, cut or hard-faced. See Operator's manual for tool sharpening methods



The DANGER decal states that there must be a protective shield between the operator and the hammer. This decal also warns against flying projectiles.



The two-position bracket decal shows the hammer horizontal and vertical operating positions.



The ALLIED LOGO decal is the Allied brand identifier and is a registered trademark of Allied Construction Products, LLC.

ARXX

The Model Number decal indicates the hammer model (AR) and the Model Number



The Pressure I.D. Tag is attached to the pressure hose for ease of identification between hoses

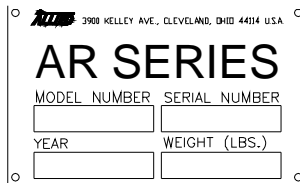

The ID PLATE (Identification Plate) contains the following information: Manufacturer's name and address, Product Name, Model Number, Serial Number, Year of Manufacture and Weight. pressure hose for ease of identification between hoses.

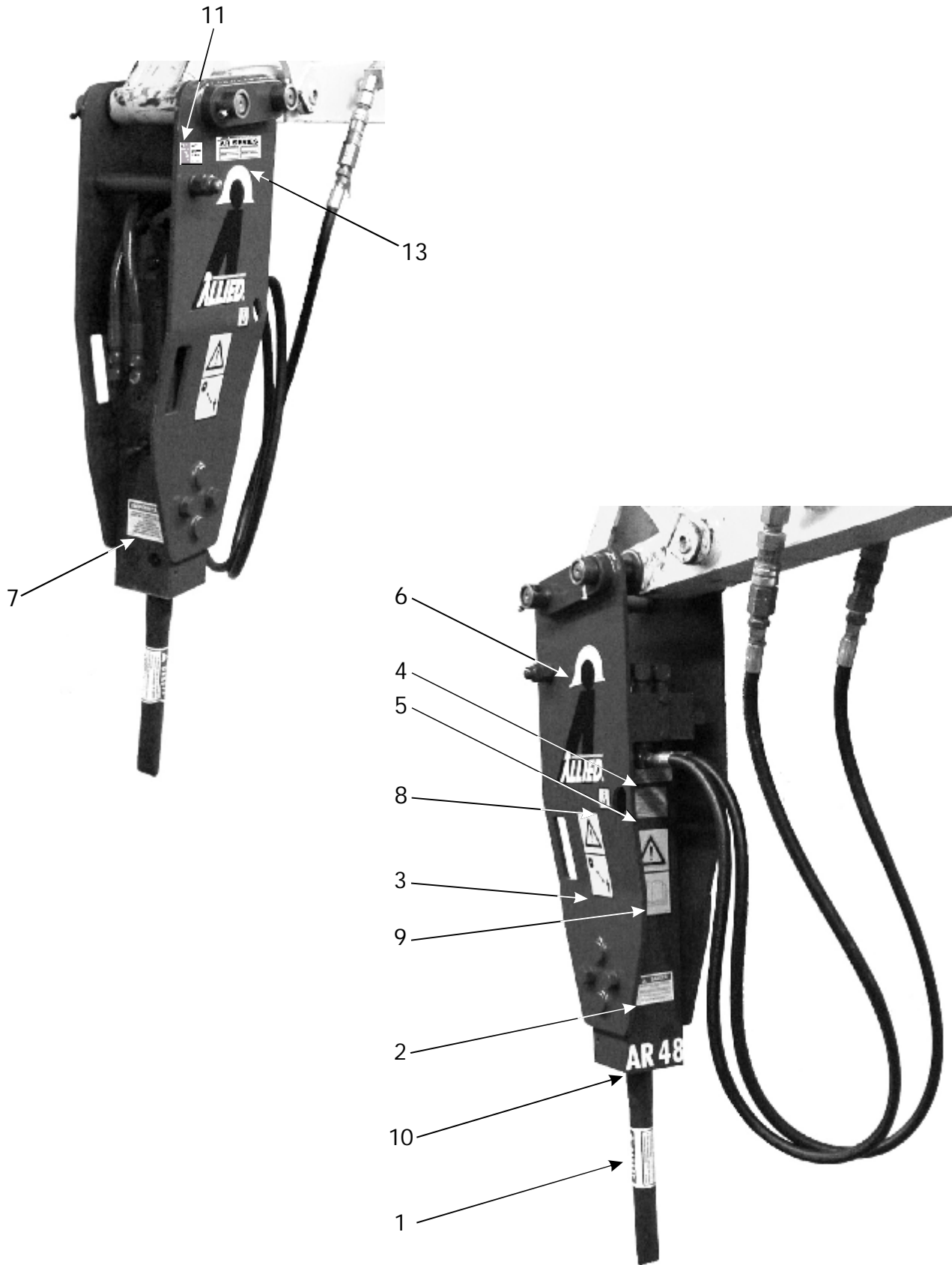

Decal Location - Mini-Excavator Configuration (XSF)

| Decal Kit Part No. 100115 | | | |
|------------------------------|------|----------|---|
| ITEM NO. | QTY. | PART NO. | DESCRIPTION |
| 1 | 1 | 657838 | Decal - Tool Sharpening/Small |
| 2 | 2 | 657839 | Decal - Danger/Small (one inside cab) |
| 3 | 2 | 657841 | Decal - Danger Stay Clear |
| 4 | 1 | 658539 | Decal - Max Hydraulic Pressure 1750 psi |
| 5 | 1 | 678955 | Decal - Nitrogen Operating Pressure - 185/215 psi |
| 6 | 2 | 676649 | Decal - Allied "A" |
| 7 | 1 | 677334 | Decal - Lube W/Tool In |
| 8 | 2 | 676982 | Decal - Lift Point |
| 9 | 1 | 676984 | Decal - Read Instructions |
| 10 | 1 | 100569 | Decal - AR 48 |
| 11 | 1 | 658658 | Decal - CIMA Energy |
| 12 | 1 | 818676 | Pressure I.D. Tag (Located on Pressure Hose) |
| 13 | 1 | 819026 | I.D. Plate (Not part of decal kit) |

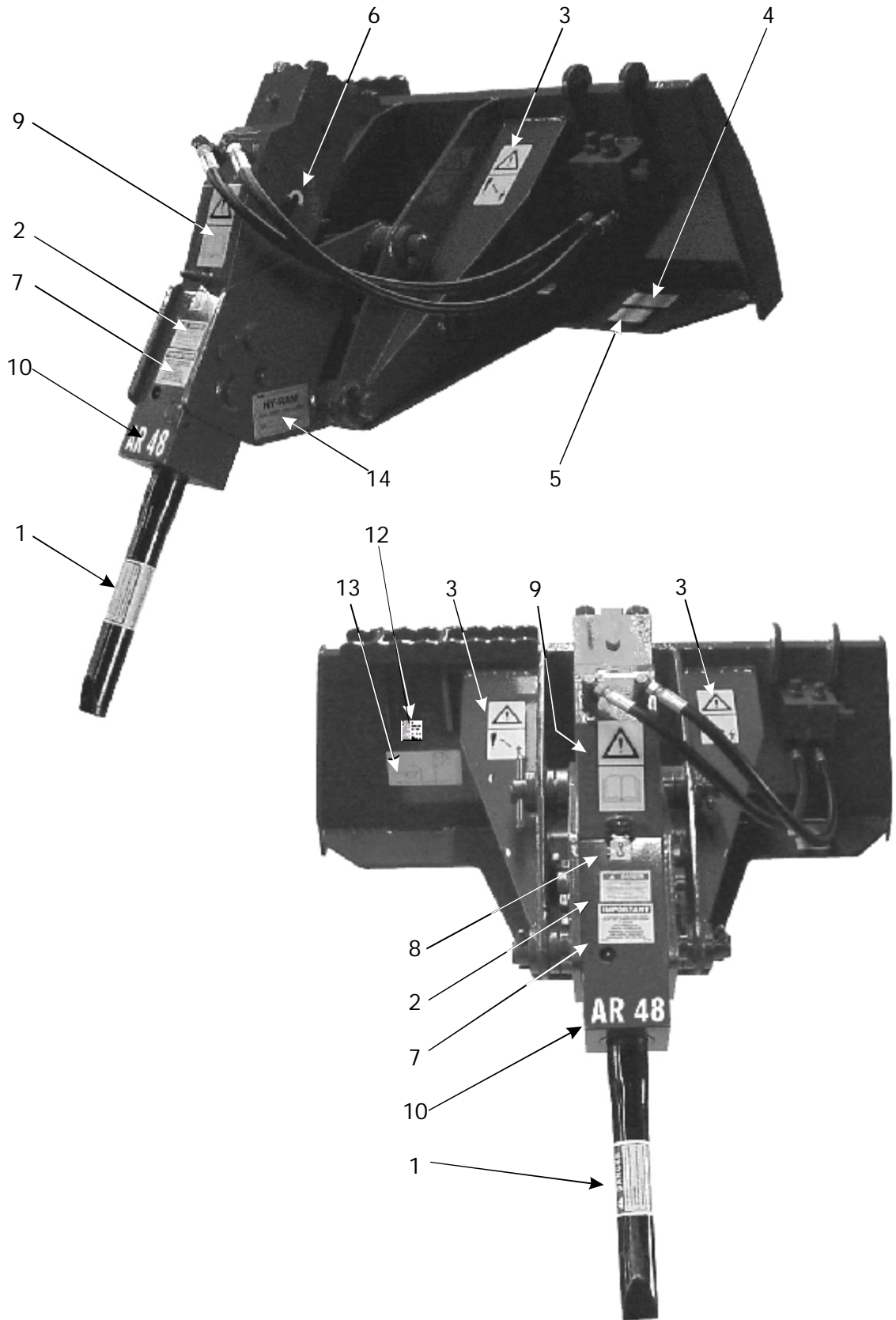

Decal Location - Skid Steer Configuration

| Decal Kit Part No. 101044 | | | |
|------------------------------|------|----------|--|
| ITEM NO. | QTY. | PART NO. | DESCRIPTION |
| 1 | 1 | 657838 | Decal - Tool Sharpening/Small |
| 2 | 2 | 657839 | Decal - Danger/Small (one inside cab) |
| 3 | 2 | 657841 | Decal - Danger Stay Clear |
| 4 | 1 | 658539 | Decal - Max Hydraulic Pressure 1750 psi |
| 5 | 1 | 678955 | Decal - Nitrogen Operating Pressure - 185/215 psi |
| 6 | 2 | 100480 | Decal - Allied "A" |
| 7 | 1 | 677334 | Decal - Lube W/Tool In |
| 8 | 1 | 676982 | Decal - Lift Point |
| 9 | 1 | 676984 | Decal - Read Instructions |
| 10 | 1 | 100569 | Decal - AR 48 |
| 11 | 1 | 818676 | Pressure I.D. Tag (Located on Pressure Hose) |
| 12 | 1 | 658658 | Decal - CIMA Eergy |
| 13 | 1 | 676941 | Decal - 2-Position Hammer Bracket Orientation (Not part of decal kit) |
| 14 | 1 | 819026 | I.D. Plate (Not part of decal kit) |



3900 Kelley Avenue, Cleveland, Ohio 44114
Tel: 216-431-2600 Fax: 216-431-2601
e-mail: Sales@AlliedCP.com
website: <http://www.AlliedCP.com>
