

RDP Series

Allied's RDP Series Pulverizers

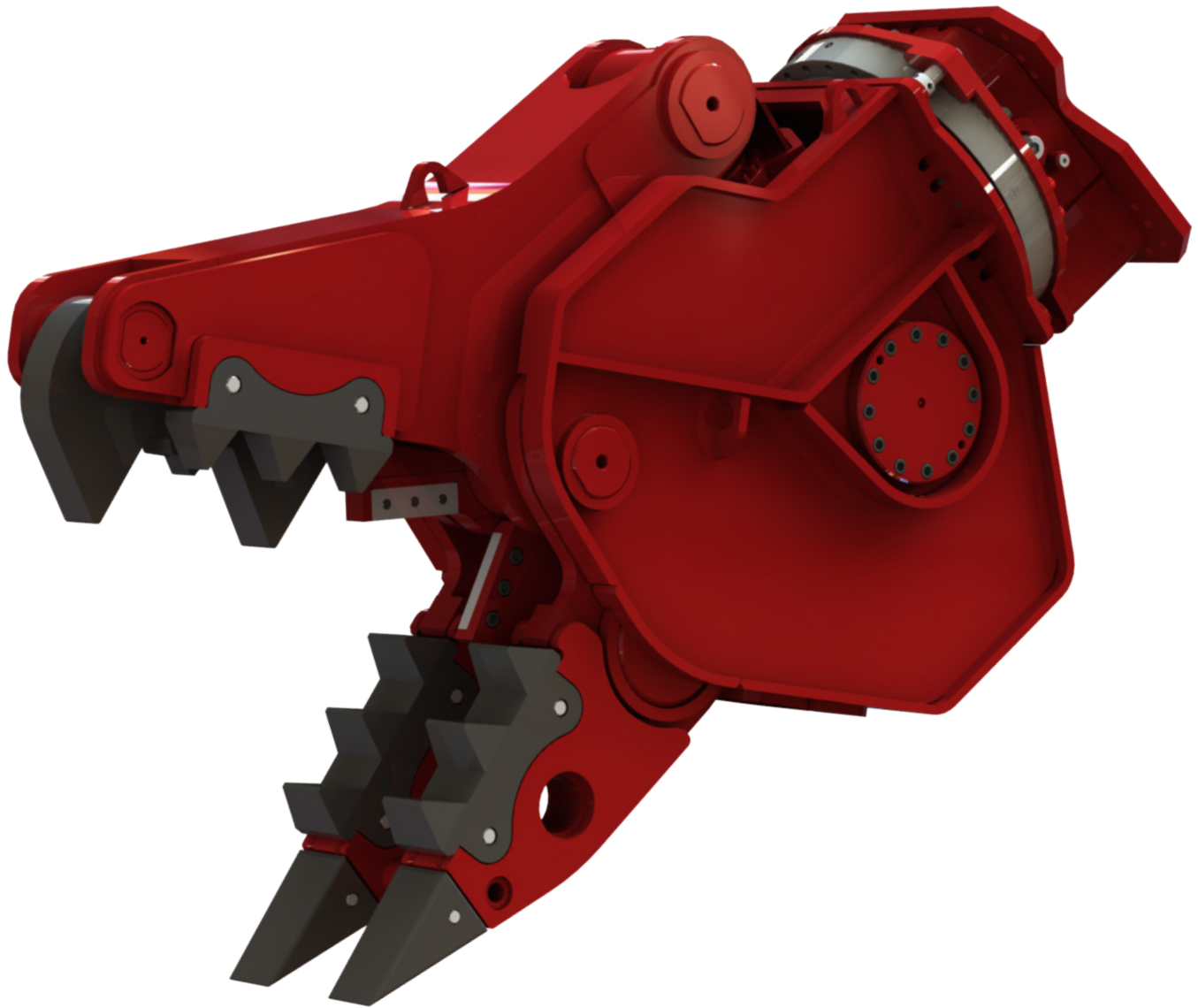

The RDP Series pulverizers pack up to 195 tons of cutting force.

The Allied RDP Series pulverizers are the ideal attachment for primary and secondary demolition. They can easily crush and separate reinforced concrete on the jobsite.

The RDP Series pulverizers have 360° rotation, extremely efficient cycle times (open/close) and in combination with the carrier minimal fuel consumption.

A powerful cylinder fitted with a special valve along with the design of the jaws, provide deep penetrating power into the concrete.

All wear parts can be taken apart and easily replaced which reduces stocking inventory.

The RDP Series pulverizers are made of high quality wear-resistant steel and are available in four different models.

The combination of light weight and center of gravity makes the RDP Series pulverizers the ideal attachment for demolition contractors.

Appetite Chart

Model		RDP 20S	RDP 25S	RDP 32S	RDP 42S
Solid Rod	in.	1.20	1.30	1.30	1.35
Concrete	in.	20	26	30	40

The above data reflects a normal appetite in normal usage and may not reflect the maximum size of each shape that can be processed. The actual results may vary depending upon actual material construction, steel properties, excavator performance and operator competence.

Allied RDP Series Pulverizers Specifications

Model		RDP 20S	RDP 25S	RDP 32S	RDP 42S
Weight	(kg)	2100	2765	3100	4500
Open/Close	(sec.)	1,9-1,2	2,2-2,4	2,5-2,8	2,6-2,8
Cutting Force Position 1 (T)	(T)	62	70	95	105
Cutting Force Position 2 (T)	(T)	100	107	152	195
Hydraulic Excavator	Tonnes	15-25	24-35	32-50	45-70
Rotar Hole Patter		140-150	140-150	140-150	150
Dimensions					
Dimensions A	(mm)	2100	2270	2458	2640
Dimensions B	(mm)	760	760	760	880
Dimensions C	(mm)	390	479	495	556
Dimensions D	(mm)	310	350	398	470
Dimensions E	(mm)	750	822	867	930
Dimensions F	(mm)	845	974	1000	1230
Dimensions G	(mm)	200	200	200	250
Hydraulic					
Maximum Operation Pressure Cylinder	(bar)	350	350	350	350
Maximum Operation Pressure Motor	(bar)	170	170	170	170
Oil Flow Cylinder	(l/min.)	150-250	150-250	250-300	250-350
Oil Flow Motor	(l/min.)	40-60	40-60	40-60	40-60

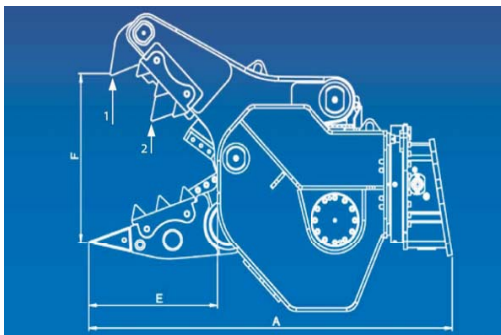

For sales and service, contact your Allied Distributor:



3900 Kelley Avenue, Cleveland, Ohio 44114
Tel: 216-431-2600 Fax: 216-431-2601
e-mail: Sales@AlliedCP.com
website: <http://www.AlliedCP.com>