

OPERATION AND MAINTENANCE

OMBC504PFENG.407

CUTTER-CRUSHER
SANDVIK BC504 PIN
SANDVIK BC504 FLANGE

<i>OPERATION</i>	3	Hardfacing crusher jaw and teeth	46
1. Foreword	4	4. Replacing crusher teeth	48
Preface	4	Welding tools	48
This manual	4	Removal of tooth	48
Important safety information	5	Installation of tooth	48
Warranty.	6	5. Troubleshooting.	50
Spare part orders.	6	Machine does not crush	50
2. Machine numbers	7	Machine does not cut	50
Model and serial number	7	Crusher jaw does not move	50
3. Product introduction.	8	Excessive moving	51
Overview.	8	Oil leakage	51
Removal from package	8	Further assistance	51
Lifting instructions	8		
Main parts	12	<i>SPECIFICATIONS</i>	53
Environmental protection and recycling policy	12	1. Crusher specifications.	54
4. Safety	14	Technical specifications	54
General safety	14	Main dimensions PIN.	54
Safety instructions.	14	Main dimensions FLANGE	55
5. Operation	19		
Operating instructions.	19		
Daily operation	21		
Mounting and dismounting the equipment	27		
Movement.	29		
Special conditions of use	29		
Storage	30		
<i>LUBRICATION</i>	31		
1. Greasing	32		
Recommended greases.	32		
Greasing points	32		
2. Carrier hydraulic oil	34		
Requirements for hydraulic oil	34		
Oil cooler	36		
Oil filter	37		
<i>MAINTENANCE</i>	39		
1. Routine maintenance	40		
Overview.	40		
Inspection and maintenance by the operator	40		
Inspection and maintenance by the dealer	41		
Maintenance intervals in special applications.	42		
Other maintenance procedures	42		
2. Turning and changing cutting blades.	43		
Wear limits, adjustments and torques for cutting blades	43		
Removal of cutting blades.	44		
Installation of cutting blades	45		
3. Hardfacing crusher jaw and teeth	46		
Welding tools	46		

OPERATION

1. FOREWORD

1.1 PREFACE

Congratulations on having purchased this product. A properly installed attachment should prove to be a productive machine requiring maintenance at only regular intervals.

1.2 THIS MANUAL

This manual is arranged to give you a good understanding of the equipment and its safe operation. It also contains maintenance information and technical specifications. Read this manual from front to back before installing, operating or maintaining the attachment for the first time.

In this manual, the units of measurement are metric. For example, weights are given in kilograms (kg). In some cases the other unit follows in parenthesis (). For example 28 litres (7.4 US gal).

The specifications and designs presented in this manual are subject to change without prior notice.

SYMBOLS USED IN THIS MANUAL

This symbol identifies important safety messages within this manual. Carefully read the message that follows. Failure to understand and obey this safety warning could result in injury to you or others, and could also cause damage to equipment. See illustration 1.

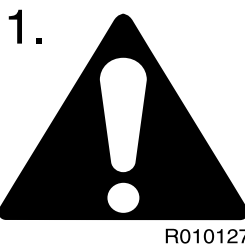

This symbol identifies prohibited action or hazardous location. Failure to understand and obey this safety warning could result in injury to you or others, and could also cause damage to equipment. See illustration 2.

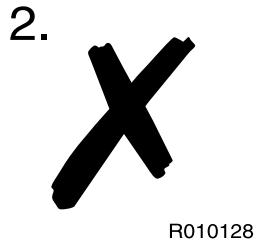

This symbol identifies correct and recommended action. See illustration 3.

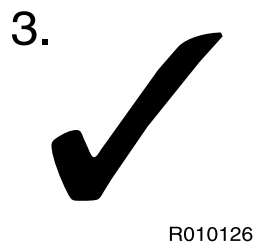

This symbol identifies environmental and recycling matter. See illustration 4.

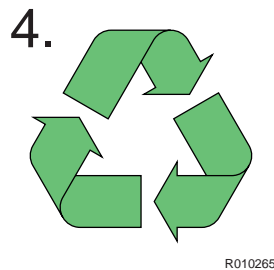

1.3 IMPORTANT SAFETY INFORMATION

Basic safety precautions are outlined in the "Safety" section of this manual and in the description of operations where hazards exist. These warnings are identified by the warning symbol.

To use the attachment correctly, you must also be a competent operator of the carrier machine. Do not use or install it if you can not use the carrier machine. The attachment is a powerful tool. Used without proper care, it can cause damage.

Do not rush when you are learning to use the product. Take your time and most importantly, take it safely. Do not guess. If there is anything you do not understand, ask your local dealer. He will be pleased to advise you.

Improper operation, lubrication or maintenance of this machine can be dangerous and could result in injury.

Do not operate this machine until you read and understand the instructions in this manual.

Do not perform any lubrication and maintenance on this machine until you read and understand the instructions in this manual.

1.4 WARRANTY

The customer is provided with a separate warranty sheet, where the export warranty terms are explained. Check always that this warranty sheet is provided with the attachment. If not, contact your local dealer immediately.

WARRANTY REGISTRATION CARD

A warranty registration card is filled out after the installation inspection by the dealer and a copy of it is sent to the manufacturer. This card is very important because no warranty claims are handled without it. Make sure that you get a copy of it after the installation inspection and that it is correctly filled out.

INSTALLATION INSPECTION

An installation inspection must be carried out after the product has been installed on the carrier. In the installation inspection certain specifications (operating pressure, oil flow, etc.) are checked so that they are within given limits.

1.5 SPARE PART ORDERS

When you need spare parts or some information concerning maintenance to your machinery, please contact your local dealer. Quick deliveries are ensured by exact orders.

Required information:

1. Name of customer, contact person
2. Order number (when available)
3. Delivery address
4. Mode of delivery (air mail, etc.)
5. Required delivery date
6. Invoicing address
7. Model and serial number of product
8. Name, number and required amount of spare parts

2. MACHINE NUMBERS

2.1 MODEL AND SERIAL NUMBER

The equipment serial number is stamped on the equipment body. The model and serial number are also located on the CE marking. Check that the model corresponds to the one given on the cover of this manual.

It is important to make correct reference to the serial number of the attachment when making repairs or ordering spare parts. Identification of the serial number is the only proper means of maintaining and identifying parts for a specific product.

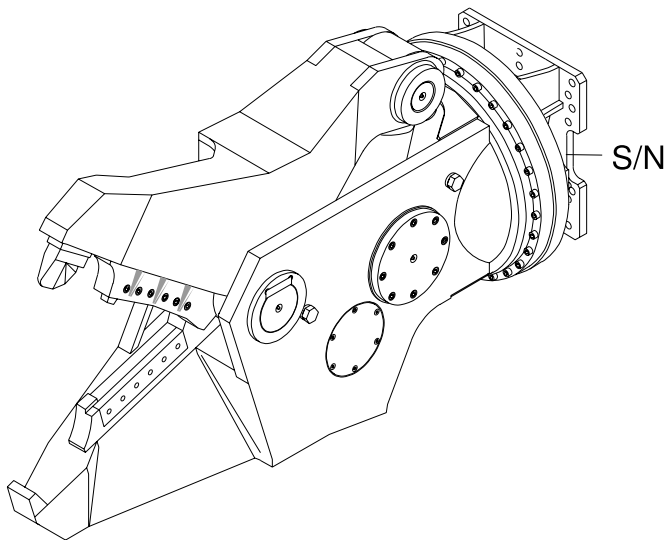

CE	
MANUFACTURING DATE	
S/N	
MODEL	
.....	kg
<i>Cylinder</i>	l/min
.....	MPa
<i>Rotation</i>	l/min
.....	MPa
<small>SANDVIK MINING AND CONSTRUCTION OY, BREAKERS LAHTI, FINLAND</small>	
	

M010078

3. PRODUCT INTRODUCTION

3.1 OVERVIEW

The product is a hydraulically operated crusher. It can be used on any carrier which meets the necessary hydraulic and mechanical installation requirements.

3.2 REMOVAL FROM PACKAGE

Remove all the steel belts from the package. Open the package and remove all plastics covering the product. Recycle all package materials (steel, plastic, wood) properly.

Check that the product is in good condition and that there is no visible damage. Check that all ordered parts and accessories have been enclosed with the product. Some options may be provided by your local dealer like installation kits; including hoses and mounting bracket.

3.3 LIFTING INSTRUCTIONS

Use a hoist when lifting components which weigh 23 kg (51 lb) or more, to avoid back injury. Make sure all chains, hooks, slings, etc., are in good condition and are in the correct capacity. Be sure hooks are positioned correctly. Lifting eye is not to be side loaded during a lifting operation.

PROVIDED LIFTING POINTS

The lifting eyes located on the Product housing are to be used solely to lift or handle the Product itself. The lifting capacity calculation is based on Product's working weight including average sized mounting bracket.



Warning! To avoid falling objects, do not use Product to lift other products. The lifting eyes located on the Product housing are to be used solely to lift or handle the Product itself.

The maximum allowed total weight is shown on the Product's CE-plate and specification page. See "Crusher specifications" on page 54. If the weight exceeds the maximum allowed total weight shown on the CE-plate and specification page, you have to use other lifting points/methods than originally provided on the Product.

The other treaded holes on the Product are intended for handling single parts only. It is forbidden to lift the entire assembly by using these threaded holes. For handling the parts, see product workshop documentation for suitable lifting methods and lifting adapters.

LIFTING EYE SCREWS

Lifting eye screws shall be completely tightened. The lifting eye must be loaded only if the screw is properly tightened to the housing.



Failure to properly tighten the screw before allowing load pressure on the lifting eye may cause lifting eye to break and free fall of the Product.

If you use mechanical tools for tightening, make sure not to overstrain the shank. Before lifting make sure that the rope and/or hook is stretched.

When two lifting eye screws are used, the lifting capacity depends on the angle of the lifting chains. The angle should not be less than 45°, as shown in the illustration. When the lifting eye screws are tightened, both rings should be aligned.

The loading capacity calculation applies to temperatures between -10 °C (14 °F) and 40 °C (104 °F).

Before reuse of lifting eye screws make sure there are no surface flaws (for example pits, voids, folds and seams, deformation of the ring, missing or broken threads, rust, etc.).

The local, national safety standards for machines and lifting-tackles must always be strictly observed.

Note: The lifting eye must always be removed from the crusher and replaced with a blanking screw before starting to operate the crusher.

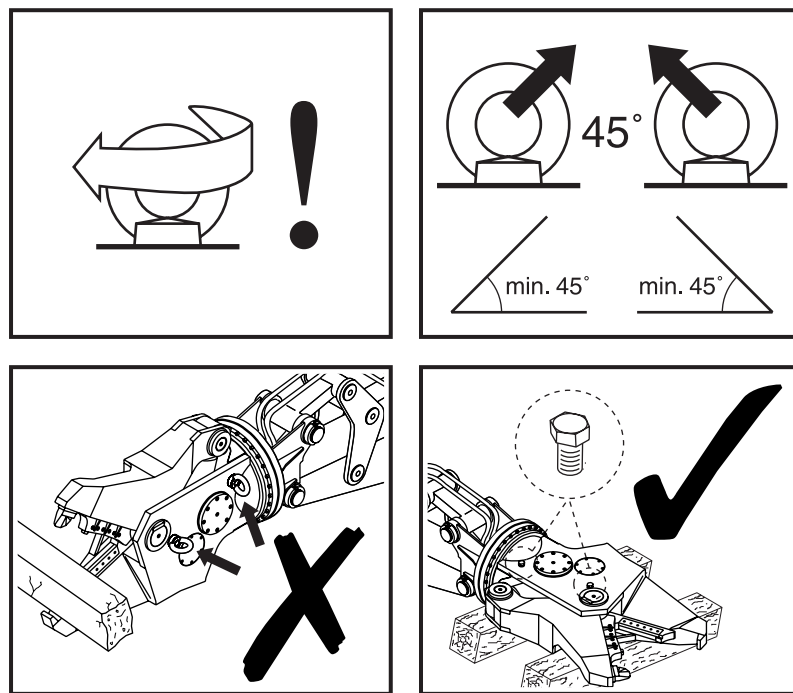

R010270

Lifting devices must safely carry the working weight of the product. See “Crusher specifications” on page 54.

Place chain or sling, as shown by the illustration, to lift the product.

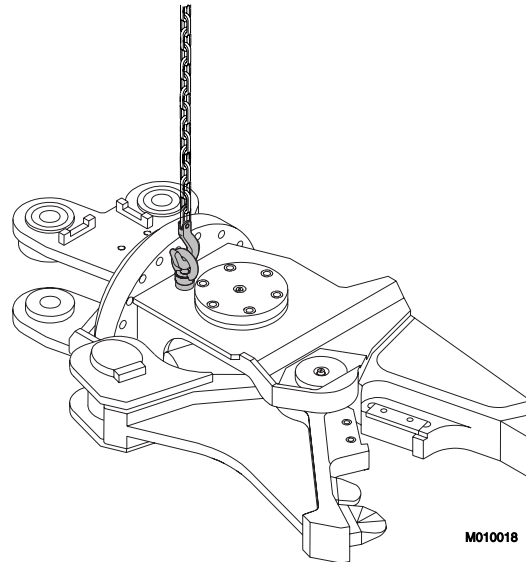

Note: The lifting eye must always be removed from the crusher and replaced with a blanking screw before starting to operate the crusher.

SAFETY INSTRUCTIONS FOR LIFTING

Below are some common safety instructions concerning lifting operations. In addition to this, the local, national standards for machines and lifting-tackles must always be strictly observed. Please note that the list below is not all inclusive, you must always ensure the procedure you choose is safe for you and others.

- Do not lift load over people. No one shall be under the hoisted load.
- Do not lift people and never ride the hoisted load.
- Keep people clear from lift area.
- Avoid side pull of the load. Make sure you take up the slack slowly. Start and stop carefully.
- Lift load a few centimeters and verify it before proceeding. Make sure the load is well balanced. Check for any loose items.
- Never leave the suspended load unattended. Maintain load control at all times.
- Never lift the load over the rated capacity (see product's operating weight from specification page).
- Inspect all lifting equipment before use. Do not use twisted or damaged lifting equipment. Protect lifting equipment from sharp corners.
- Obey all local safety instructions.

3.4 MAIN PARTS

The main parts of the cutter-crusher are shown below.

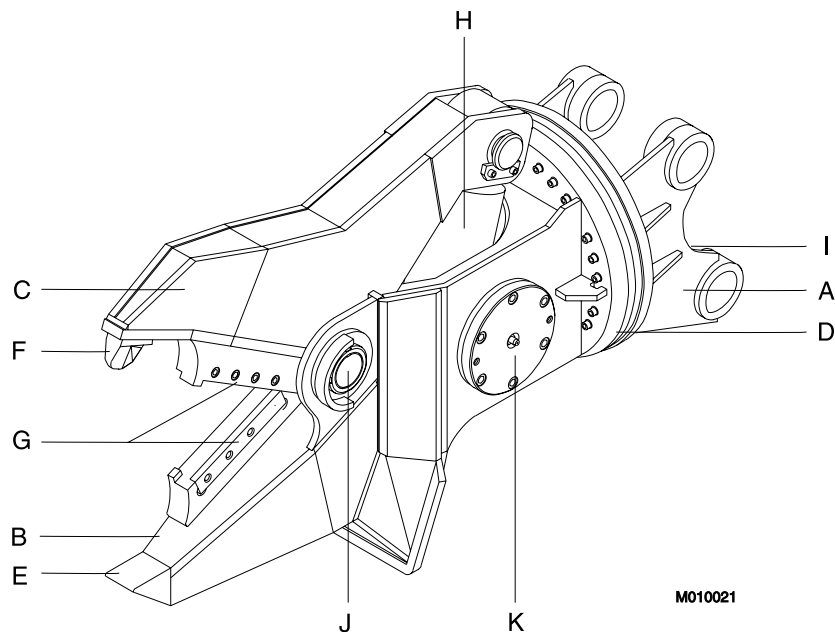

- A. Mounting bracket
- B. Fixed jaw
- C. Moving jaw
- D. Slew bearing
- E. Front tooth
- F. Breaking tooth
- G. Cutting blades
- H. Cylinder
- I. Brake/Hydraulic motor
- J. Pivot pin
- K. Trunnion bearing

3.5 ENVIRONMENTAL PROTECTION AND RECYCLING POLICY

Sandvik manufactures products which contribute to the recycling of materials to help customers achieve their environmental objectives. During the manufacturing all the necessary precautions are taken to make sure that no harm is done to the environment.

Sandvik strives to foresee and minimize the risks that might be caused by operation or maintenance of products, which could expose humans or the environment to danger. Rammer support customers in their efforts to consider the environmental protection in their everyday work.

When working with Sandvik product please follow these guidelines:

- Dispose of packaging materials properly. Wood and plastic can be burned or recycled. Deliver the steel belts to metal recycling center.

- Protect environment from oil spills.

In case of hydraulic oil leaks, the equipment should be serviced immediately.

Follow the product's greasing instructions and avoid excessive greasing.

Be careful when handling, storing and transporting oils.

Dispose of empty oil or grease containers appropriately.

Consult local authorities for detailed instructions.

- All metal parts of the product can be recycled by delivering them to an authorized scrap metal collection facility.
- Comply with local waste classification rules when disposing of used rubber or plastic parts (buffers, wear plates, seals).
- When scrapping the whole product or pressure accumulator, consult your local Sandvik dealer for instructions on depressurizing the accumulator.
- Do not bring the product or accumulator to a scrap metal collection center before depressurizing the accumulator first.

Consult with your local dealer for more information.

4. SAFETY

4.1 GENERAL SAFETY

All mechanical equipment can be hazardous if operated without due care or correct maintenance. Most accidents involving machine operation and maintenance are caused by failure to observe basic safety rules or precautions. An accident can often be avoided by recognizing potentially hazardous situations before an accident occurs.

Because it is impossible to anticipate every possible circumstance that might involve a potential hazard, the warnings in this guide and on the machine are not all inclusive. If a procedure, tool, working method or operating technique not specifically recommended by manufacturer is used, you must satisfy yourself that it is safe for you and others. You should also ensure that the product will not be damaged or made unsafe by the method of operation or maintenance procedures you choose.

Safety is not just a matter of responding to the warnings. All the time you are working with your attachment you must pay attention to what hazards there might be and how to avoid them. Do not work with the product until you are sure that you control it. Do not start any job until you are sure that you and those around you will be safe.



Warning! Read the following warning messages carefully. They tell you of different hazards and how to avoid them. If proper precautions are not taken you or others could be seriously injured.

4.2 SAFETY INSTRUCTIONS

MANUALS

Study this manual before installing, operating or maintaining the product. If there is anything you don't understand, ask your employer or your local dealer to explain it. Keep this manual clean and in good condition.

Study also the operating and maintenance manual of your carrier before operating the attachment.

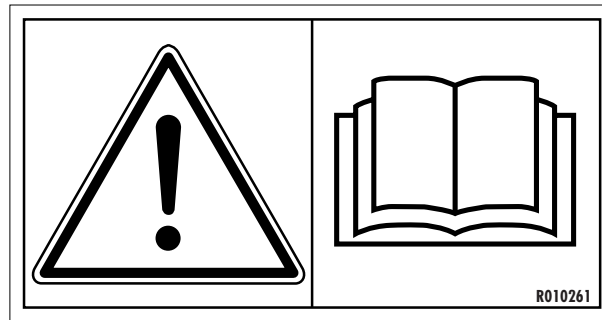

CARE AND ALERTNESS

All the time you are working with the product, take care and stay alert. Always be careful. Always be alert for hazards. The possibility of a serious or even fatal accident is increased when you are intoxicated.

CLOTHING

You can be injured if you do not wear proper clothing. Loose clothing can get caught in the machinery. Wear protective clothing to suit the job.

Examples are: a safety helmet, safety shoes, safety glasses, well-fitting overalls, ear-protectors and industrial gloves. Keep cuffs fastened. Do not wear a necktie or scarf. Keep long hair restrained.

PRACTICE

You and others can be killed or injured if you do unfamiliar operations without practising them first. Practice away from the job site, in a clear area.

Keep other people away. Do not perform new operations until you are sure you can do them safely.

REGULATIONS AND LAWS

Obey all laws, work site and local regulations which affect you and your equipment.

COMMUNICATIONS

Bad communications can cause accidents. Keep people around you informed of what you will be doing. If you will be working with other people make sure they understand any hand signals you will be using.

Work sites can be noisy. Do not rely on spoken commands.

WORK SITE

Work sites can be hazardous. Inspect the site before working on it.

Check for potholes, weak ground, hidden rocks, etc. Check for utilities (electric cables, gas and water pipes, etc.). Mark the positions of cables and pipes.

Poor visibility can cause accidents and damage. Make sure that visibility and lightning of the working area are adequate.

Work sites can be noisy. Wear ear protection to prevent personal injury.



BANKS AND TRENCHES

Banked material and trenches can collapse. Do not work too close to banks and trenches where there is a danger of collapse.

SAFETY BARRIERS

Unguarded equipment in public places can be dangerous. Place barriers around the machine to keep people away.

FLYING DEMOLITION DEBRIS

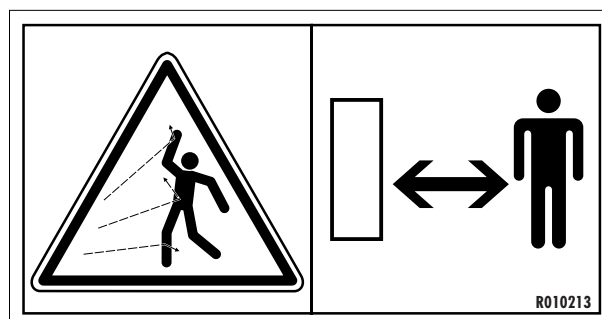

Protect yourself and your surroundings from flying debris. Do not operate the product or carrier with people around it.

Keep the cabin windows and doors closed during operation. Window bars are recommended to protect the windows from flying debris.

COLLAPSING CONCRETE FRAMES

Protect yourself and your surroundings from collapsing concrete frames. Do not operate the product or carrier with people around it.

EQUIPMENT LIMITS

Operating the product beyond its design limits can cause damage. It can also be dangerous. See “Crusher specifications” on page 54.

Do not try to upgrade the product's performance by unapproved modifications.

HYDRAULIC FLUID

Fine jets of hydraulic fluid at high pressure can penetrate the skin. Do not use your fingers to check for hydraulic fluid leaks. Do not put your face close to suspected leaks. Hold a piece of cardboard close to suspected leaks and then inspect the cardboard for signs of hydraulic fluid. If hydraulic fluid penetrates your skin seek medical help immediately.

Hot hydraulic fluid can cause severe injuries.

HYDRAULIC HOSES AND FITTINGS

Ensure all hydraulic components will withstand maximum pressure and mechanical stresses caused by operation of the attachment. Consult your local dealer for instructions.

FIRE HAZARD

Most hydraulic fluids are flammable and might ignite when contacting hot surface. Avoid spilling hydraulic fluid to hot surfaces.

Working with the product on certain materials can cause sparks and hot splinters to get loose. These can ignite flammable materials around working area.

Ensure that adequate extinguisher is available.

HYDRAULIC PRESSURE

Hydraulic fluid at system pressure can injure you. Before disconnecting or connecting hydraulic hoses, stop the carrier engine, operate the controls to release pressure trapped in the hoses. During the operation, keep people away from the hydraulic hoses.

There might be pressurized oil trapped inside the product even if it is disconnected from the carrier. Be aware of possible unexpected jaw movements while greasing or removing and installing cutting blades. See “Turning and changing cutting blades” on page 43.

LIFTING EQUIPMENT

You can be injured if you use faulty lifting equipment. Make sure that lifting equipment is in good condition. Make sure that the lifting tackle complies with all local regulations and is suitable for the job. Make sure that the lifting equipment is strong enough for the job and you know how to use it.

Do not use this product or any of its parts for lifting. See “Lifting instructions” on page 8. Contact your carrier dealer to find out how to lift with your carrier.

SPARE PARTS

Use only genuine spare parts. Use only genuine cutting blades with crushers. The use of other spare part or cutting blade brands may damage the product.

EQUIPMENT CONDITION

Defective equipment can injure you or others. Do not operate equipment which is defective or has missing parts.

Make sure the maintenance procedures in this manual are completed before using the product.

REPAIRS AND MAINTENANCE

Do not try to do repairs or any other maintenance work you do not understand.

MODIFICATIONS AND WELDING

Non-approved modifications can cause injury and damage. Contact your local dealer for advice before modifying the product. Before welding on the product while it is installed on the carrier, consult your carrier dealer for precautions in welding.

METAL SPLINTERS

You can be injured by flying splinters when driving metal pins in and out. Use soft-faced hammer or drifts to remove and fit metal pins, such as pivot pins. Always wear safety glasses.

5. OPERATION

5.1 OPERATING INSTRUCTIONS

RECOMMENDED USE

The cutter-crusher is designed for use in demolishing work to crush concrete and cut steel beams in buildings and bridge demolition. It can be also used in recycling plants for cutting fastening iron and steel frames. Your local dealer will gladly give you more information.

OPERATING CONDITIONS

Principles of installation

Almost all carriers meeting mechanical and hydraulic requirements can be used to operate attachments. See “Crusher specifications” on page 54. The product is installed on the carrier much in the same manner as installing a bucket or other attachments. A flange mounted attachment requires also a separate mounting bracket.

The attachment is connected to a carrier's hydraulic circuit with an installation kit. If the carrier is already fitted with an installation kit, the installation requires only suitable hoses and fittings. For crusher installation, secondary relief valves in bucket cylinder circuit and in carrier auxiliary circuit are needed. If the carrier does not have suitable kit to run attachments, one must be built. This may require more complex installation including new piping and additional valves such as flow control valve or pressure relief valve.

Suitable kits can be ordered from the manufacturer or local dealers, from carrier manufacturers and their dealers or from third party suppliers.

Hydraulic oil

In general the hydraulic oil originally intended for the carrier can be used with this product. See “Requirements for hydraulic oil” on page 34.

Operating temperature

The operating temperature is -20 °C (-4 °F) to 80 °C (176 °F). If you must work in a temperature lower than -20 °C (-4 °F), the equipment has to be preheated before any operations can begin. Start the operation with low hydraulic flow.

Note: The temperature of the hydraulic oil must be monitored. Ensure that oil grade and monitored oil temperature together guarantee correct oil viscosity. See “Oil specifications” on page 35.

PRINCIPLES OF OPERATION

The operation of the equipment is based on a static force produced by the hydraulic cylinder of the equipment. To increase the product's working life, pay particular attention to correct working methods.

Crushing is performed in the front of the crusher jaws. Avoid using cutting blades for crushing.

Cutting is performed with cutting blades at the rear of the crushing mouth. The cutting blades can be reversed.

CRUSHER JAWS, TEETH AND CUTTING BLADES

Crusher jaws

Crusher jaws are operated by the hydraulic cylinder of the crusher. One jaw is fixed and the other, equipped with breaking tooth, is moving. Crushing is performed using the crushing teeth of the jaws.

Breaking tooth

The long-lasting convex shaped breaking tooth is made of special steel.

Cutting blades

The cutting blades are fastened with screws and can be turned, so that all four cutting edges can be used or replaced with new cutting blades. See "Turning and changing cutting blades" on page 43.

The stopper nipple at the outer end of the blade prevents steel beams from slipping from cutting blades.

5.2 DAILY OPERATION



Warning! Protect yourself and your surroundings from flying debris and collapsing concrete frames. Do not operate the cutter-crusher or carrier with people around it.



The cutter-crusher must not be used under water.

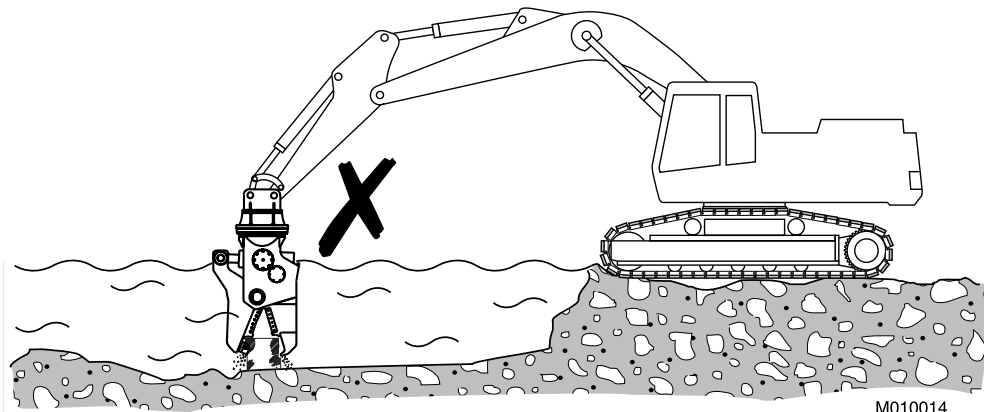

M010014



Warning! Cutting of steel cables or hardened steel wires with cutter-crusher may be difficult due to the flexibility of the material. The steel cable or hardened wire can be deflected or bent within the jaw area, and may cause serious damage to the cutter-crusher. Consult with your local dealer for more information.

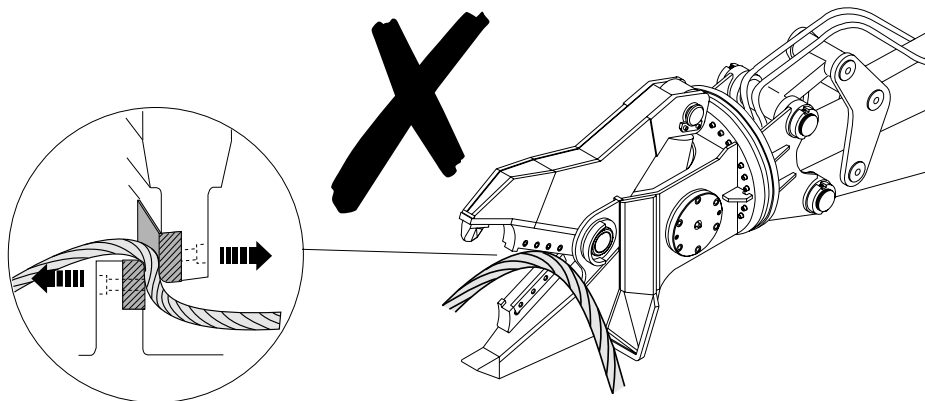

M010057



In models equipped with a slew lock, remember to unlock the slew before starting operation. See “Mounting and dismounting the equipment” on page 27.

1. Prepare the carrier for normal excavation work. Move the carrier to the required position. Set the drive to neutral.
2. Set the engine speed to the recommended engine RPM.
3. Carefully operate the carrier controls to place the cutter-crusher and boom into the crushing position. Quick and careless boom movements could result in damage to the cutter-crusher.

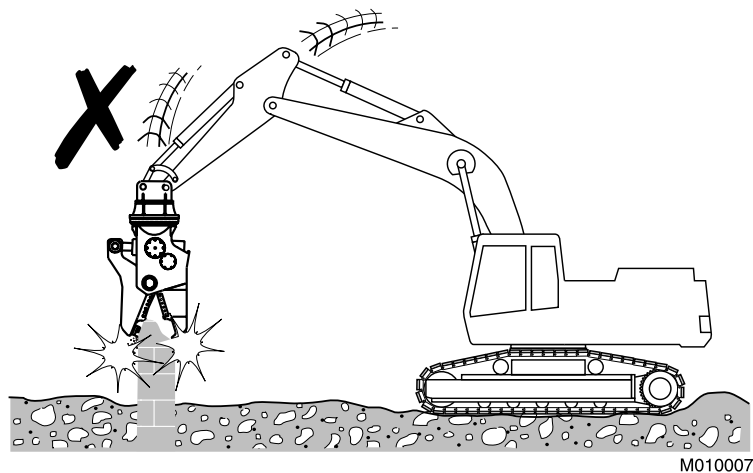

4. Open the crusher jaws, position the object on the fixed jaw side by operating excavator cylinders and close the jaws to crush. When the crusher jaws are closed, a slewing function will work enabling crushing in right angle. The best crushing result is obtained by using the tooth area of the crusher jaws. Avoid crushing concrete with cutting blades.

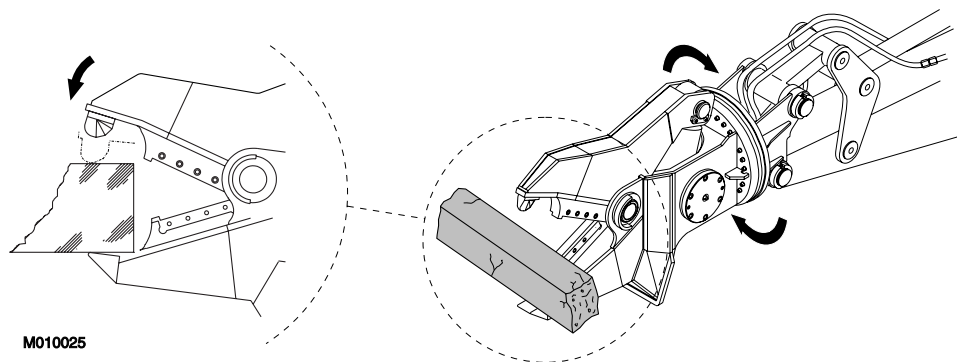

- Concrete blocks can easily be demolished by first crushing in one point so that the structure breaks and then crushing in another point to multiple fractures. Finish demolition by crushing and cutting between the two points. Note: When demolishing prestressed concrete blocks, be careful not to damage the crusher on extra hard steel ribbons inside the concrete.

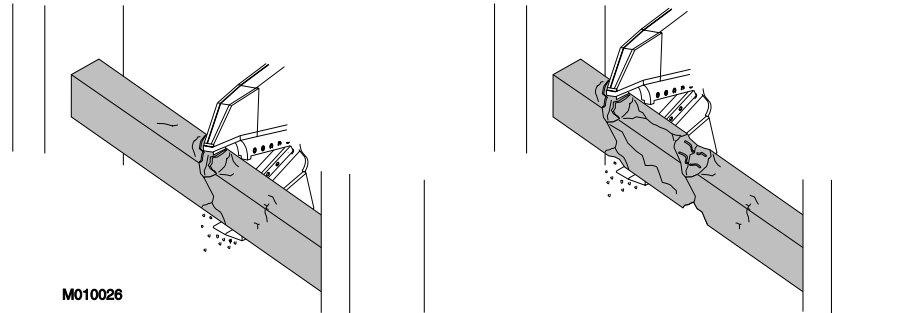

- A safety screen is recommended to protect the operator from flying debris. Keep the cabin windows and doors closed during operation.

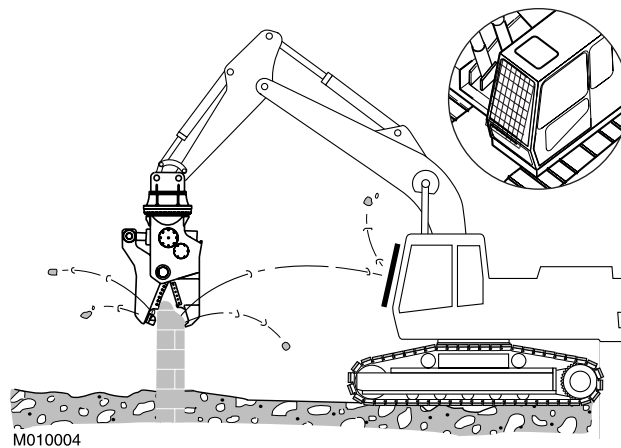

- To cut, open the crusher jaws, position the object on the cutting blade on the fixed jaw side and close crusher jaws. When the crusher jaws close, a slewing function will work enabling cutting in right angle.

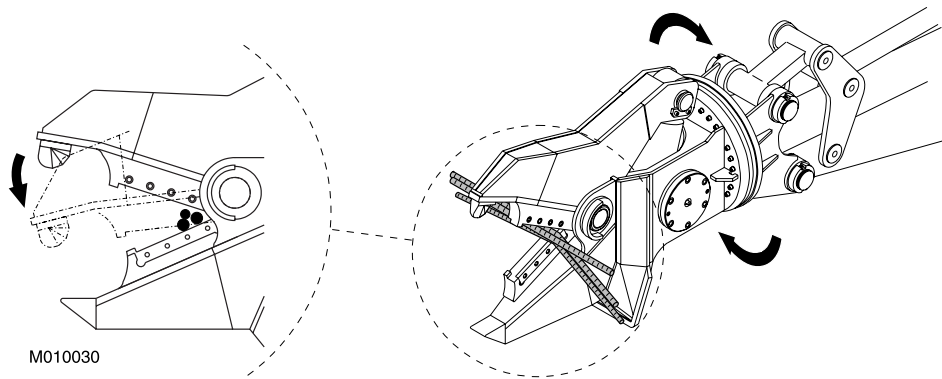

8. When cutting horizontal steel frames, concentrate the shearing action at the proper working angle. Cut through in one point at the other end of the frame. Cut partially through in another point. Then bend the framework down using the cutter-crusher and make final cut.

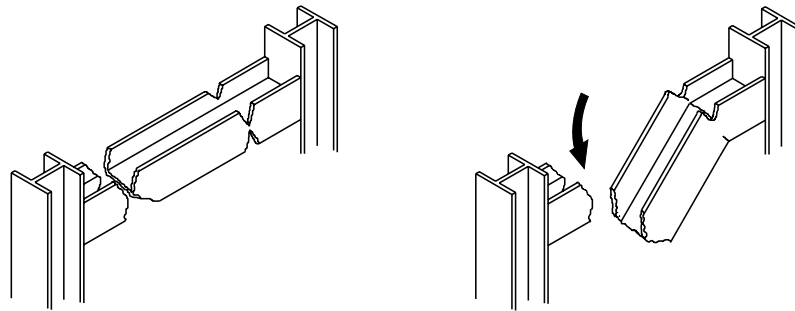

M010012

9. Place steel frames properly between cutting blades, as shown in the illustration. Note: If the cutting object does not fit into the crusher mouth, first press it between the jaws to flatten it and then perform final cutting with cutting blades.

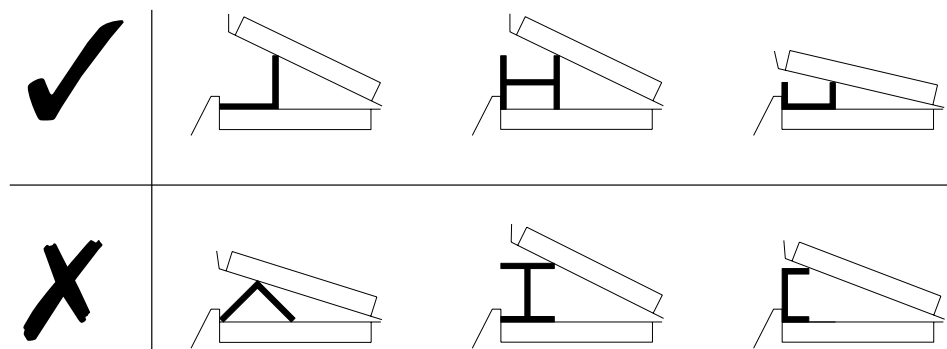

M010013

10. As a rule, when the angle between the upper and lower cutting blade is less than 30 degrees the object will not slip.
11. The cutter-crusher is intended for cutting and crushing, do not use the cutter-crusher as a lever or to strike, hit or ram objects. Do not use the side of the cutter-crusher to move concrete or objects.
12. Do not use cutter-crusher for lifting. Lifting eyes on the cutter-crusher are for storage and maintenance purposes only.

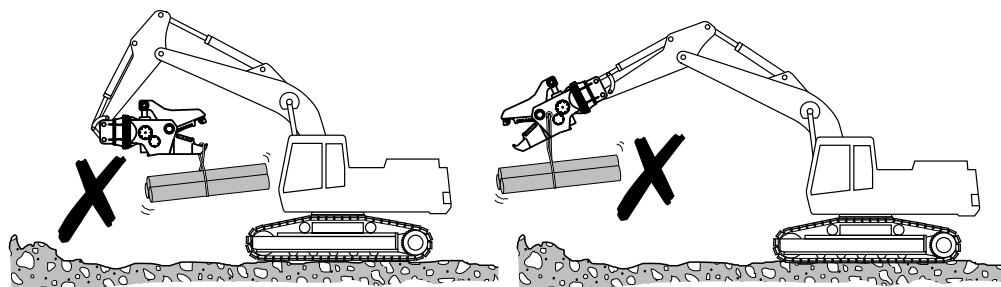

M010006

13. Do not use cutter-crusher for moving excavator.

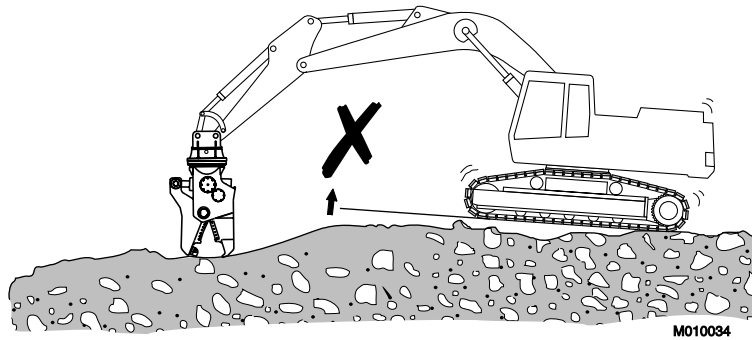

14. When operating the cutter-crusher, make sure that it does not make contact with the carrier boom or hydraulic lines.

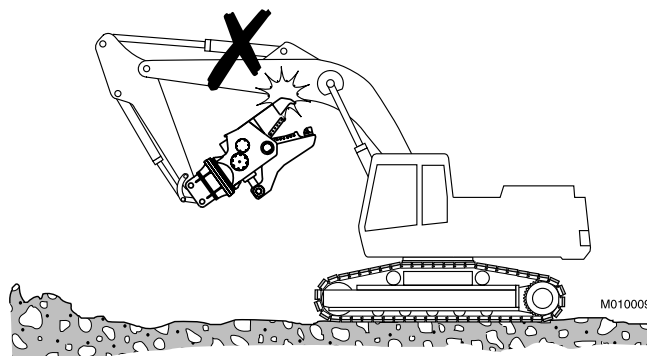

15. Do not operate crusher jaws with the carrier's boom stick or bucket cylinders at the end of their stroke (either fully extended or retracted). Damage to the carrier may result.

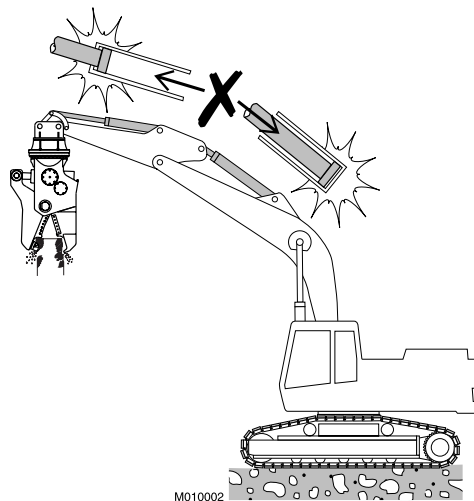

16. When the crusher jaws are closed, the cylinder rod is exposed. The operator must take care not to hit the rod with concrete or iron bars. Damage to the cylinder rod may cause rod seal breakage and oil leaks.

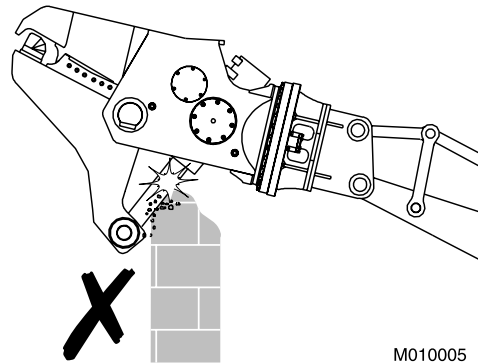

17. Getting steel frame or rebar between crusher jaws and cylinder rod clevis can cause damage to the cylinder rod or crusher jaws. To avoid cylinder damage, always remove demolition debris from the housing.

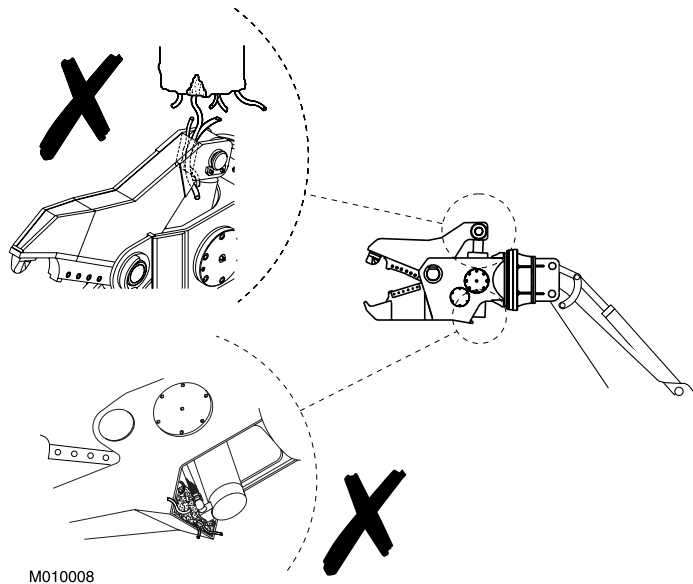

18. Do not operate excavator hydraulic cylinders when the crusher jaws are closed. Bending the object up and down when the cutter-crusher jaws are pressed on it may cause excessive wearing of cutter-crusher teeth and cutting blades.

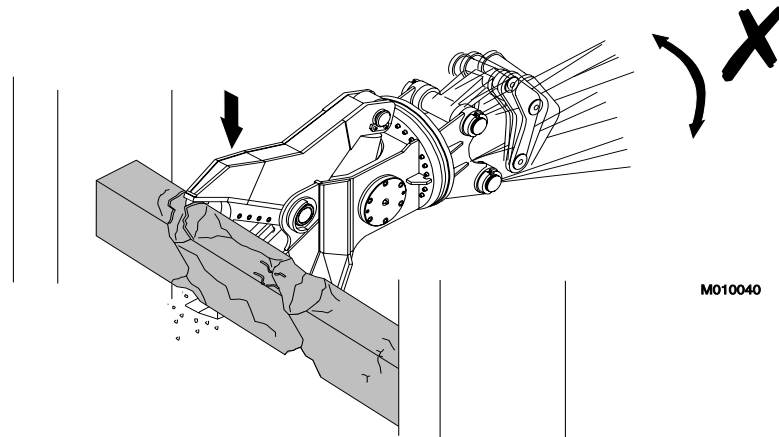

19. The bearings must be well greased during operation. Regular inspections during operation are recommended. If no grease is visible, bearings require more frequent greasing. Bearings covered with excessive grease require less frequent greasing.

5.3 MOUNTING AND DISMOUNTING THE EQUIPMENT

REMOVAL FROM CARRIER



Warning! The equipment must be secured from rolling over when disconnecting from the carrier. Only use skilled operator to position carrier for the removal!

Warning! Hydraulic pressure inside the equipment must always be released before opening hose connections!

Warning! Hot hydraulic fluid can cause severe injuries!

1. Position attachment horizontally on the floor.
2. Stop the carrier engine. Operate boom and attachment controls to release pressure trapped inside hoses.
3. Close attachment shut-off valve. If quick couplers are used, disconnection automatically closes attachment lines. If the line includes ball valves, please make sure that they are closed.
4. Disconnect hoses. Protect environment from oil spills. Plug the hoses.

5. Remove bucket pins and other parts.

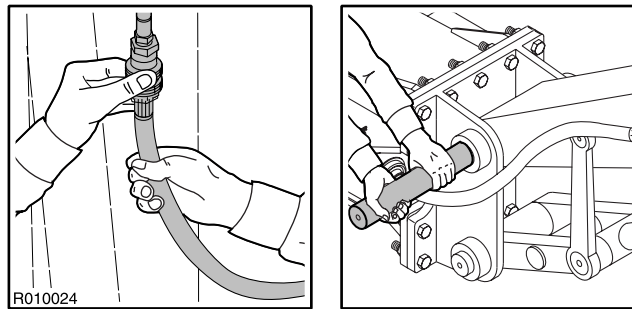

6. The carrier can be moved aside.

INSTALLATION



Warning! The residual air in the hoses must always be removed before operation!

1. Install equipment in the same manner as mounting a bucket. Install bucket pins.
2. Connect hoses.
3. Open the ball valves.
4. Remove air from the hoses by carefully operating the crusher cylinder. Open and close empty jaws several times.

5.4 MOVEMENT

The transportation and parking positions are shown below. When moving the carrier, ensure that the crusher is not too close to the carrier.

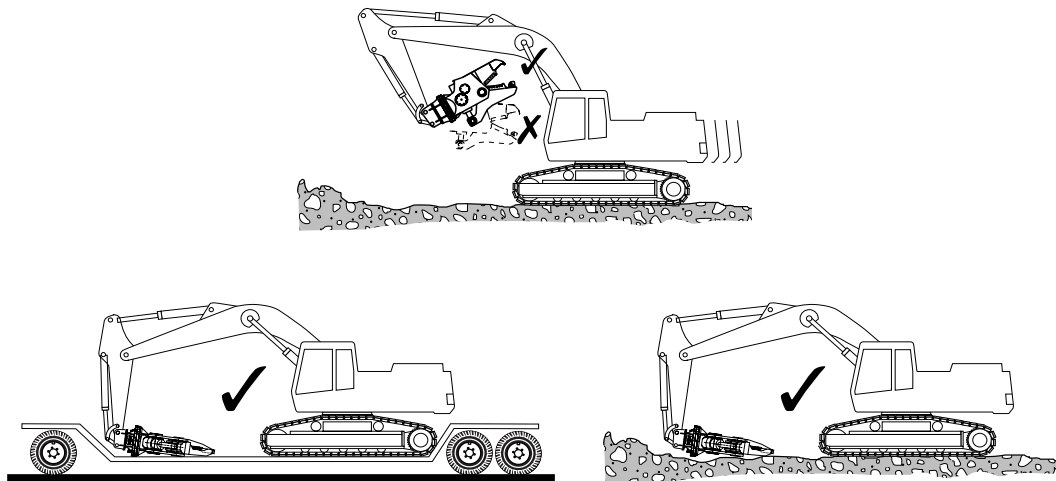

M010043

5.5 SPECIAL CONDITIONS OF USE

The equipment may require modifications, special operating techniques, increased maintenance or special wear items if it is used in conditions that differ from normal breaking or demolition work. Special conditions of use are:

- Operations in extremely low or high temperatures
- Use of special hydraulic fluids
- Operations with special carrier
- Other special conditions

In case of special conditions of use, please consult your local dealer for instructions.



The cutter-crusher must not be used under water.

5.6 STORAGE

LONG TERM STORAGE

Observe the following points when the product is stored. In this way the vital parts of the attachment are protected from rust and the machine is ready to be used whenever necessary.

1. The storage area must be dry.
2. To avoid damaging the cylinder rod, operate the cylinder to the shortest position by leaving the crusher jaws open.
3. Insert blocks under the crusher to keep it off the ground. If the machine is stored outside, cover it to prevent rusting.

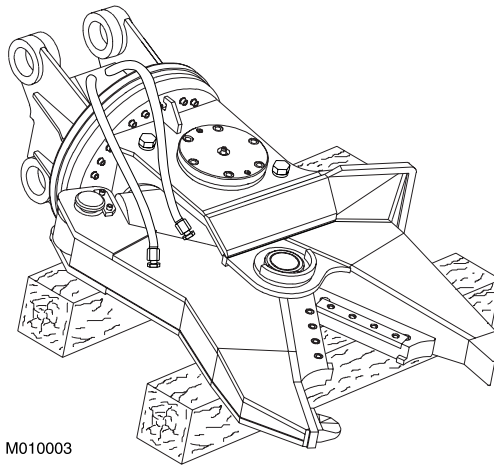

M010003

4. Apply grease to all crusher parts. Protect mounting bracket, pin holes, cutting blades and pivot ends with an anticorrosive agent.
5. Connections must be sealed with clean plugs to prevent oil leakage and dirt from getting into couplings.
6. Make sure the product can not fall.

LUBRICATION

1. GREASING

1.1 RECOMMENDED GREASES

<i>Item</i>	<i>Recommended greases</i>	<i>Greasing interval</i>
Crusher parts	ESSO Beacon EP2	every 8 hours
	SHELL Retinax EP2	
	FUCHS Lubritech, Lagermeister EP 2	
	MOBIL Mobilux EP 2	
Slew bearing	ESSO Beacon EP2	every 150 hours
	SHELL Retinax EP2	
	FUCHS Lubritech, Lagermeister EP 2	
	MOBIL Mobilux EP 2	

1.2 GREASING POINTS



Follow the product's greasing instructions and avoid excessive greasing. Dispose of empty grease containers appropriately.

The greasing points of the crusher have been marked with the following sticker.

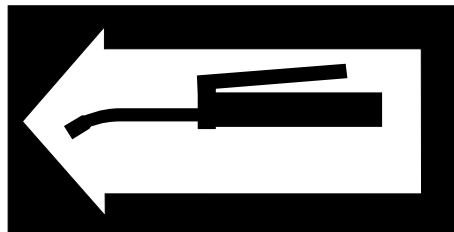

R020002

The greasing points of the crusher are shown below.

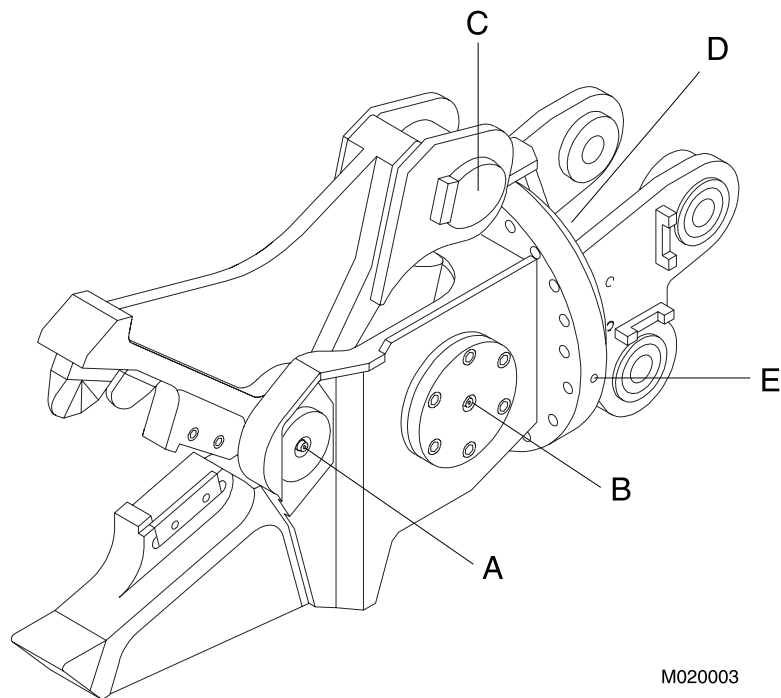

M020003

- A. Main shaft
- B. Trunnion
- C. Rod pin
- D. Center swivel
- E. Slew bearing

CRUSHER PARTS

1. Always grease before operation and after every 8 hours of operation.
 2. Adapt greasing interval and amount of grease to working conditions.
- Insufficient greasing or improper grease may cause abnormal wear of parts.

SLEW BEARING

1. Grease adequately after every 150 hours of operation.
2. Adapt greasing interval and amount of grease to working conditions.
3. Apply grease from grease gun to grease nipples. It is important to rotate the slewing ring during lubrication. Complete the lubrication after rotation.

Insufficient greasing or improper grease may cause abnormal wear of parts.

Note: Use only grease specified for slew bearing.

2. CARRIER HYDRAULIC OIL

2.1 REQUIREMENTS FOR HYDRAULIC OIL

GENERAL REQUIREMENTS

In general the hydraulic oil originally intended for the carrier can be used with this product. However, since working with the product heats the oil more than the usual excavation work, the temperature of the oil must be monitored.

If the temperature of the hydraulic oil exceeds 80 °C (176 °F), an auxiliary oil cooler is needed. The oil viscosity must be between 1000-20 cSt while the attachment is being used.

When the product is used continuously, the temperature of the hydraulic oil normalizes at a certain level depending on conditions and on the carrier. The temperature in the tank must not exceed the maximum allowed.

The attachment must not be started if the ambient temperature is below freezing and the oil is very thick. The machine must be moved to bring the oil temperature above 0 °C (32 °F) before working can start (viscosity 1000 cSt or 131 °E).

OIL SPECIFICATIONS

Table below shows hydraulic oils recommended for equipment use. The most suitable oil is selected in such a way that the temperature of the hydraulic oil in continuous use is in the ideal area on the chart and the hydraulic system is used to best advantage.

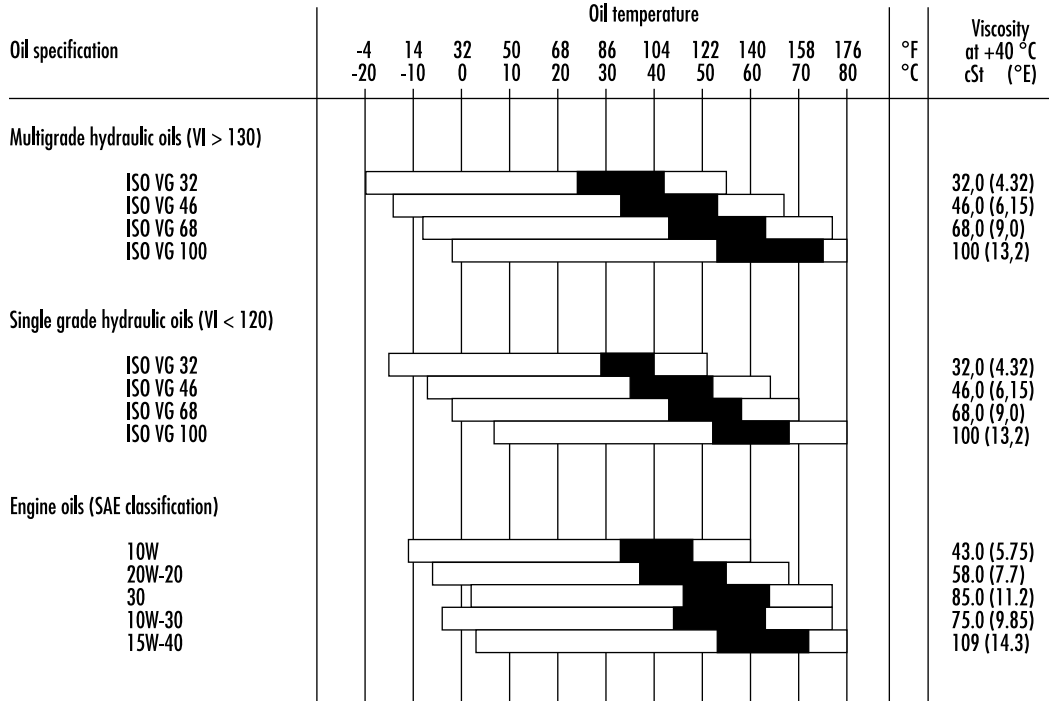

VI = Viscosity index
 □ Permitted oil temperature
 ■ Recommended oil temperature

R020004

Problems due to incorrect hydraulic oil viscosity in the equipment:

Oil too thick

- Difficult start up
- Stiff operation
- Danger of cavitation
- Sticky valves
- Filter bypass opens, impurities in the oil are not removed

Oil too thin

- Efficiency losses (internal leaks)
- Damage to gaskets and seals, leaks
- Accelerated wearing of parts, because of decreased lubrication efficiency
- Danger of cavitation

Note: We strongly recommend the use of different hydraulic oils in the summer and in the winter if there is an average temperature difference of more than 35 °C (95 °F). The correct hydraulic oil viscosity is thus ensured.

SPECIAL OILS

In some cases special oils (e.g. biological oils and non-flammable oils) can be used with the crushers. Observe the following aspects when considering the use of special oils:

- The viscosity range in the special oil must be in the given range (20-1000 cSt)
- The lubrication properties must be sufficient
- The corrosion resistance properties must be good enough

Note: Although a special oil could be used in the carrier, always check its suitability with the attachment. Contact the oil manufacturer or your local dealer for more information about special oils.

2.2 OIL COOLER

The carrier hydraulic system must be able to maintain the temperature within an acceptable level during the crusher operation. This is for two reasons.

1. Seals, wipers, membranes and other parts manufactured from the corresponding materials can normally stand temperatures up to 80 °C (176 °F).
2. The higher the temperature is, the less viscous the oil gets thus losing its capability to lubricate.

A standard carrier, with a proper crusher circuit, meets the requirements of the necessary cooling capacity. If the oil temperature tends to be too high during the crusher operation, the following things must be checked:

- The crusher circuit pressure relief valve should not be opened unnecessarily.
- The crusher circuit pressure drops must be reasonable, less than 20 bar (290 psi) in the hydraulic line.
- There should be no internal leakages in crusher or in carrier hydraulic pumps, valves, cylinders, motors, etc.

If all of the above mentioned things are in order, and the temperature of the hydraulic oil still tends to be too high, extra cooling capacity is needed. Consult the carrier manufacturer or dealer for details.

2.3 OIL FILTER

The purpose of the oil filter is to remove impurities from the hydraulic oil. Air and water are also impurities in oil. Not all impurities can be seen with the naked eye.

Impurities enter the hydraulic system:

- During hydraulic oil changes and refilling.
- When components are repaired or serviced.
- When the attachment is being installed on the carrier.
- Because of component wear.

Normally the existing main oil filters of the carrier are used as attachment circuit return line filters. Consult the carrier manufacturer or your local dealer concerning instructions for the filter change intervals.

In crusher work the carrier oil filter must fulfil the following specifications:

- The oil filter must allow maximum particle size of 25 microns (0.025 mm).
- The oil filter material must be man-made fibre cloth or very fine gauge metallic mesh to withstand pressure fluctuations.
- The oil filter must have a nominal flow capacity of at least twice the attachment's maximum flow.

In general, oil companies guarantee new oils to have a particle count of 40 microns maximum. Filter the oil when filling the tank.

The damage caused by hydraulic oil impurities in the carrier and attachment circuits:

Shortened working life of pumps and other components

- Rapid wear of parts.
- Cavitation.
- Wear of cylinder and gaskets.

Reduced attachment efficiency

- Accelerated wear of moving parts and seals.
- Oil leakages.

Shortened working life and reduced lubricating capability of oil

- Overheated oil.
- Deteriorated oil quality.
- Electro-chemical changes in hydraulic oil.

Malfunction of valves

- Binding spools.
- Rapid wear of parts.
- Blocking of small holes.

Note: Component damage is only a symptom. The trouble itself will not be cured by removing the symptom. After any component damage due to impurities in the oil, the entire hydraulic system has to be cleaned. Dismantle, clean and reassemble the crusher and change the hydraulic oil.

MAINTENANCE

1. ROUTINE MAINTENANCE

1.1 OVERVIEW

This product is a precision made hydraulic machine. Therefore great care and cleanliness should be taken when handling any of the hydraulic components. Dirt is the worst enemy in hydraulic systems.

Handle the parts carefully and remember to cover any cleaned and dried parts with clean lint-free cloth. Do not use anything other than purpose designed materials for cleaning hydraulic parts. Never use water, paint thinners or carbon tetrachloride.

Components, gaskets and seals in the hydraulic system should be oiled with clean hydraulic oil before assembly.

Remember to grease the crusher parts regularly according to the instructions in this manual. See “Greasing” on page 32.

Close the crusher jaws during maintenance or inspection. If you must leave the jaws open, remember to block the jaws to prevent them from closing.

Prior to maintenance or inspection, operate all the control levers to their fully extended stroke. This will release pressure within the hydraulic piping and prevent unexpected movement of the jaw and loss of oil through the hydraulic lines.

1.2 INSPECTION AND MAINTENANCE BY THE OPERATOR

Note: The times given refer to the carrier hours while the attachment is installed.

EVERY EIGHT HOURS

Grease main shaft, trunnion and rod pin. See “Recommended greases” on page 32.

DAILY MAINTENANCE

1. Check the hydraulic hoses and hose connections. Tighten if necessary.
2. Check the cutting blades and their clearance. Tighten bolts or replace the cutting blades, if necessary. See “Turning and changing cutting blades” on page 43.

3. Check the crusher jaws and teeth for wear. Hardface or replace, if necessary. See “Hardfacing crusher jaw and teeth” on page 46. See “Replacing crusher teeth” on page 48.
4. Check the grease nipples.

WEEKLY MAINTENANCE

1. Check the main body for wear.
2. Check the pins and bushings for wear.
3. Check cylinder rod, seals and connection points for wear. Tighten if necessary.
4. Observe hydraulic oil temperature, all lines and connections.
5. Check that the crusher works smoothly by operating the jaws.
6. Tighten connections, if necessary.

EVERY 150 HOURS

Grease slew bearing. See “Recommended greases” on page 32.

1.3 INSPECTION AND MAINTENANCE BY THE DEALER

Note: The times given refer to the carrier hours while the attachment is installed.

INITIAL 50-H INSPECTION

It is recommended to have the first inspection done by your local dealer after 50 to 100 operating hours. Contact your local dealer for more information about the initial 50-hour inspection.

EVERY 600 HOURS OR ONCE A YEAR

This service is recommended to be done by your local dealer after 600 operating hours. Neglecting the yearly service can cause severe damage to the crusher.

Your local dealer will reseal the crusher and replace safety decals as needed. Contact your local dealer for more information about yearly servicing.

During this maintenance you should do the following tasks.

- Check all hydraulic connections.
- Check that the hydraulic hoses do not rub against anything in any boom/stick position.

1.4 MAINTENANCE INTERVALS IN SPECIAL APPLICATIONS

The service interval is considerably shorter with special applications. See “Special conditions of use” on page 29. In special applications, please consult your local dealer for the correct service intervals.



The cutter-crusher must not be used under water.

1.5 OTHER MAINTENANCE PROCEDURES

WASHING THE ATTACHMENT

When working with attachment and removing it from the carrier, dirt (mud, rock powder, etc.) can become attached to it. Wash the outside of the product with a steam washer before sending it to the workshop. Dirt can cause difficulties in disassembly and assembly otherwise.

CAUTION! Plug the pressure and return line before washing the product or else dirt can enter into it and this may cause damage to the components.

2. TURNING AND CHANGING CUTTING BLADES

WEAR LIMITS, ADJUSTMENTS AND TORQUES FOR CUTTING BLADES

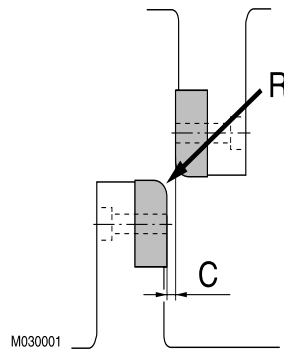

<i>Item</i>	<i>Wear limit</i>
Cutting blade edge max. radius (R)	4 mm (0.16 in)
<i>Item</i>	<i>Adjustment</i>
Cutting blade clearance (C)	0.5...1.0 mm (0.02...0.04 in)
<i>Item</i>	<i>Tightening torque</i>
Cutting blade screw	49 Nm (36 lbf ft)

REMOVAL OF CUTTING BLADES



Warning! Prior to maintenance or inspection, operate all the control levers to their fully extended stroke. This will release pressure within the hydraulic piping and prevent unexpected movement of the jaw and loss of oil through the hydraulic lines.

Warning! Support the crusher jaw to prevent it from closing unexpectedly during maintenance.

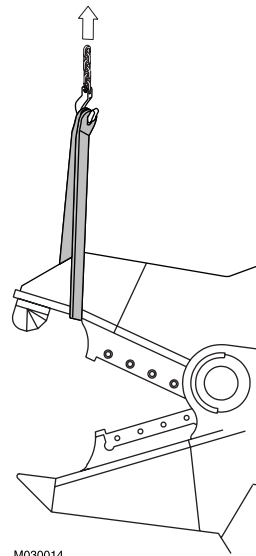

M030014



Used cutting blades can be recycled. Contact your dealer for more information about local regulations of recycling.

1. Position the attachment on level ground.
2. Support the crusher jaw.
3. Make sure the carrier's transmission is in neutral and the parking brake is engaged.
4. Stop the carrier engine.
5. Clean the cutting blades and the base.
6. Remove hex socket-head screws and lock washers.

- Remove cutting blades and shim plates.

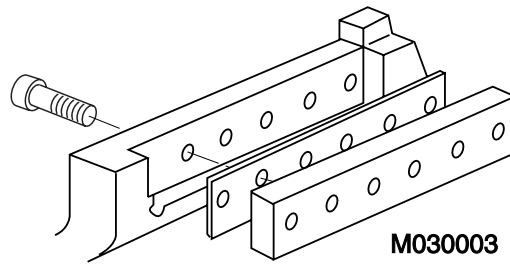

- Finish the surfaces by grinding, flush all burrs from cutting blade and cutter base.

Note: If burrs remain on the surface the cutting blade will not have proper contact with the cutter base. This will cause breakage of the cutting blade.

INSTALLATION OF CUTTING BLADES

- Reverse the cutting blade so that unused edge can be used or install a new cutting blade.
- Set cutting blade on the base.
- Fit cutting blade into cutter base with a couple of screws.
- Use a plastic hammer to seat cutting blade into its place with proper contact.
- Close crusher jaws and measure the clearance between cutting blades.
- Adjust the clearance (C) between cutting blades according to specifications. If necessary add or remove shim plates.

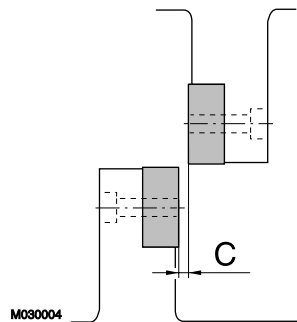

- Install lock washers and hex socket-head screws.
- Torque screws to the specified setting.

3. HARDFACING CRUSHER JAW AND TEETH

WELDING TOOLS

<i>Item</i>	<i>Welding tool</i>
Repair of parent	MIG-wire, DIN 8559: SG 2
	Welding rod, DIN 1913: E 51 53 B 10
Hardfacing	MIG-wire, DIN 8555: SG 6 - 60
	Welding rod, DIN 8555: E 6 - 55

HARDFACING CRUSHER JAW AND TEETH



Welding must occur in a workshop with proper welding tools. If you must weld the crusher when it is installed in carrier, consult your carrier dealer for precautions during welding.

Warning! Support the crusher jaw to prevent it from closing unexpectedly during maintenance.

1. Position the attachment on level ground.
2. Support the crusher jaw.
3. Carefully remove the worn part by carbon arc gouging or by gas cutting at the base. Note: Connect earth cable to the part to be repaired.
4. Repair parent by filling it with welding rod, and finish the surface by grinding.
5. Preheat hardfacing area to 100 °C (212 °F)...150 °C (302 °F).

6. Perform hardfacing. The hardfacing area of the crusher is shown in the illustration below.

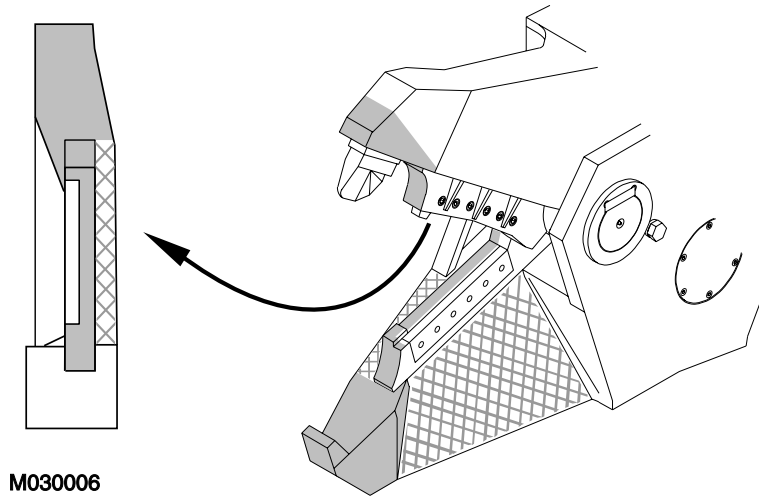

4. REPLACING CRUSHER TEETH

WELDING TOOLS

<i>Item</i>	<i>Welding tool</i>
Repair of parent, installation of tooth	MIG-wire, DIN 8559: SG 2
	Welding rod, DIN 1913: E 51 53 B 10
Hardfacing	MIG-wire, DIN 8555: SG 6 - 60
	Welding rod, DIN 8555: E 6 - 55

REMOVAL OF TOOTH



Welding must occur in a workshop with proper welding tools. If you must weld the crusher when it is installed in carrier, consult your carrier dealer for precautions during welding.

Warning! Support the crusher jaw to prevent it from closing unexpectedly during maintenance.

1. Position the attachment on level ground.
2. Support the crusher jaws.
3. Cut off the worn part by carbon arc gouging or by gas cutting at the base.
Note: Connect earth cable to the part to be repaired.
4. Repair parent by filling it with welding rod, and finish the surface by grinding.
5. Make edge preparation on the body side.

INSTALLATION OF TOOTH

1. Tack the new part with welding rod. Note: Connect earth cable to the part to be repaired.
2. Remove the block from the crusher mouth.

3. Close the crusher jaws to make sure that the front tooth and the side tooth do not touch the fixed jaw.

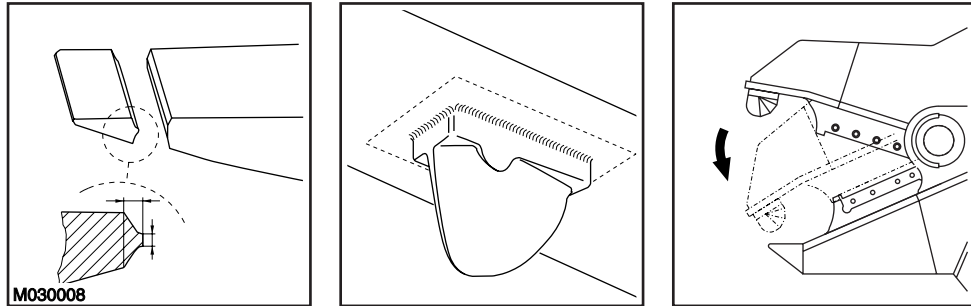

4. Preheat the jaw and the part to 100 °C (212 °F)...150 °C (302 °F).
5. Perform welding.

5. TROUBLESHOOTING

5.1 MACHINE DOES NOT CRUSH

WORN CRUSHER TEETH

Perform new hardfacing. See “Hardfacing crusher jaw and teeth” on page 46.
If necessary, change tooth. See “Replacing crusher teeth” on page 48.

DROP IN HYDRAULIC PRESSURE ON BASE MACHINE

Adjust pressure. See “Crusher specifications” on page 54.

OIL LEAKAGE WITHIN CYLINDER

The attachment must be serviced in an authorized Sandvik service shop.

5.2 MACHINE DOES NOT CUT

WORN CUTTING BLADES

Turn over the cutting blades and adjust. If necessary, change the cutting blades. See “Turning and changing cutting blades” on page 43.

CUTTING BLADE DOES NOT FIT PROPERLY ONTO THE CUTTER BASE

Refit and tighten with bolts. See “Turning and changing cutting blades” on page 43.

INCORRECT CLEARANCE BETWEEN THE BLADES AND BASE

Check the clearance and adjust. See “Turning and changing cutting blades” on page 43.

DROP IN HYDRAULIC PRESSURE ON BASE MACHINE

Adjust pressure. See “Crusher specifications” on page 54.

OIL LEAKAGE WITHIN CYLINDER

The attachment must be serviced in an authorized Sandvik service shop.

5.3 CRUSHER JAW DOES NOT MOVE

MALFUNCTION IN EXCAVATOR HYDRAULIC SYSTEM

Check the operation of auxiliary circuit.

BALL VALVES MAY BE CLOSED

Open the ball valves.

CRUSHER JAW MAY BE BLOCKED

Remove obstacles.

OIL LEAKAGE WITHIN CYLINDER

The attachment must be serviced in an authorized Sandvik service shop.

CYLINDER ROD IS BENT

The attachment must be serviced in an authorized Sandvik service shop.

5.4 EXCESSIVE MOVING

WORN PINS AND BUSHINGS

The attachment must be serviced in an authorized Sandvik service shop.

5.5 OIL LEAKAGE

OIL LEAKAGE AT HOSE END

Check the hose end and tighten.

OIL LEAKAGE AT SWIVEL JOINT

The attachment must be serviced in an authorized Sandvik service shop.

CYLINDER SEALS ARE DAMAGED

The attachment must be serviced in an authorized Sandvik service shop.

5.6 FURTHER ASSISTANCE

FURTHER ASSISTANCE

If further assistance is required, please prepare to answer the following questions before calling your dealer.

- Model and serial number
- Working hours and service history
- Carrier model
- Installation: Oil flow, operating pressure and return line pressure if known
- Application
- Has the product operated normally before

SPECIFICATIONS

1. CRUSHER SPECIFICATIONS

1.1 TECHNICAL SPECIFICATIONS

Item	Specification
Weight	205 kg (452 lb)
Max. jaw opening	312 mm (12.28 in)
Max. cutting force	460 kN (103412 lbf)
Max. crushing force	180 kN (40466 lbf)
Max. operating pressure	250 bar (3630 psi)
Oil flow (recom.)	40 l/min (10.6 gal/min)
Hose connections	SAE JIC 08 (3/4-16)
Cutting blade length	100 mm (3.94 in)
Optimum oil temperature	40...60 °C (104...140 °F)
Allowed oil temperature range	-20...80 °C (-4...176 °F)
Optimum oil viscosity at operating temperature	30...60 cSt (30...60 cSt)
Allowed oil viscosity range	20...1000 cSt (20...1000 cSt)
Carrier weight ^a	2.5...6 t (5500...13200 lb)

a. Check carrier's lifting capacity from carrier manufacturer

1.2 MAIN DIMENSIONS PIN

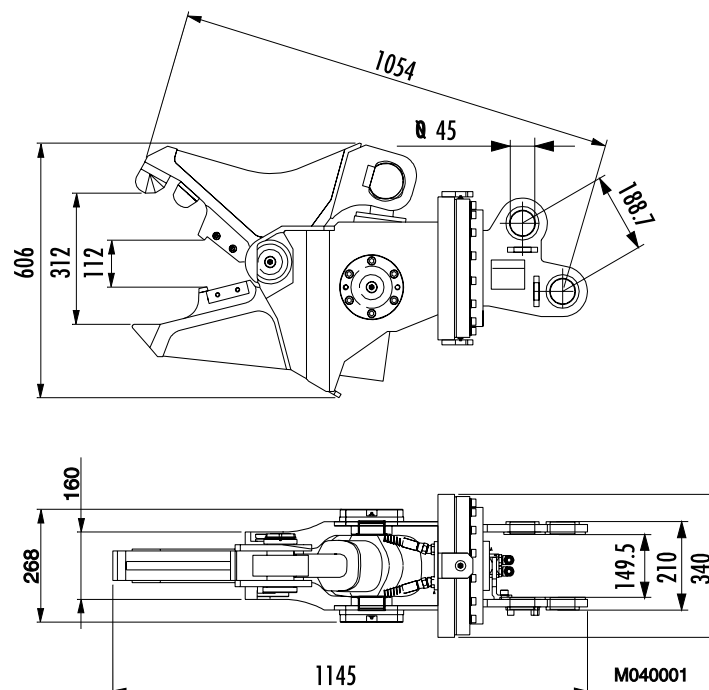

1.3 MAIN DIMENSIONS FLANGE

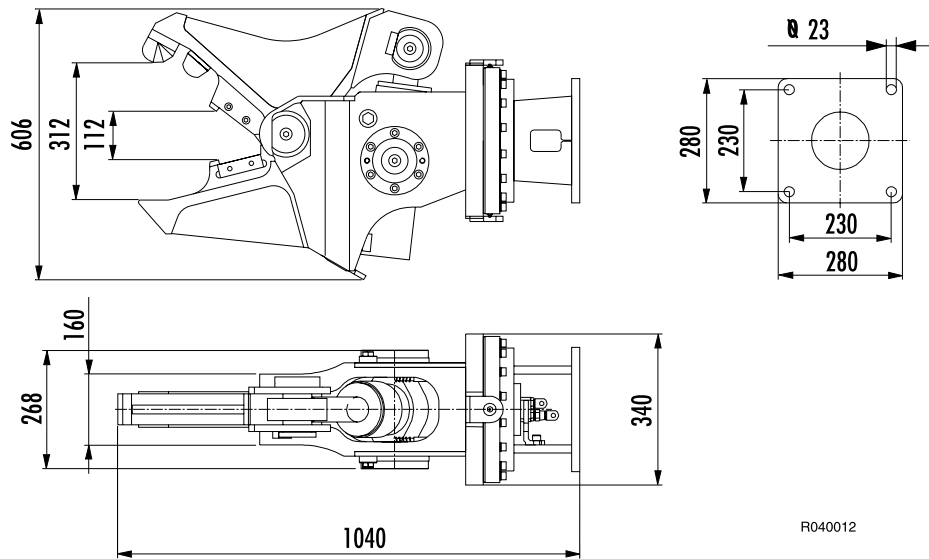

Sandvik Mining and Construction Oy, Breakers Lahti
Taivalkatu 8, P.O. Box 165, FI-15101 Lahti, Finland
Phone Int. +358 205 44 161, Telefax Int. +358 205 44 160
www.miningandconstruction.sandvik.com