

**OPERATION AND MAINTENANCE**  
**OME65SCENG.903**

**HYDRAULIC HAMMER**  
**RAMMER E 65**  
**RAMMER E 65 CITY**

---

**OPERATION..... 3**

1. Foreword .....	4
Preface .....	4
This manual .....	4
Important safety information .....	5
Warranty.....	6
Spare part orders.....	6
2. Machine numbers .....	7
Model and serial number .....	7
3. Product introduction.....	8
Overview.....	8
Removal from package .....	8
Lifting instructions .....	8
Main parts .....	10
4. Safety .....	11
General safety .....	11
Safety instructions.....	11
5. Optional equipment .....	16
Ramlube .....	16
6. Operation .....	17
Operating instructions.....	17
Daily operation.....	20
Mounting and dismounting the hammer	27
Movement.....	28
Special conditions of use .....	28
Storage .....	29

**LUBRICATION .....** **31**

1. Hammer tool greasing.....	32
Recommended greases.....	32
Manual greasing .....	32
Automatic lubrication .....	33
2. Carrier hydraulic oil .....	34
Requirements for hydraulic oil .....	34
Oil cooler .....	36
Oil filter .....	37

**MAINTENANCE .....** **39**

1. Routine maintenance .....	40
Overview.....	40
Inspection and maintenance by the operator .....	40
Inspection and maintenance by the dealer .....	41
Maintenance intervals in special applications.....	41
Other maintenance procedures .....	42
2. Removal of tool .....	43
Wear limits and lubricants for tool removal.....	43
Removal of tool .....	43
Installation of tool.....	44
3. Lower tool bushing.....	46
Wear limits and lubricants for lower tool bushing .....	46

Removal of lower tool bushing.....	46
Installation of lower tool bushing.....	47
4. Troubleshooting.....	49
The hammer does not start.....	49
The hammer operates irregularly but the blow has full power .....	49
The hammer operates irregularly and blow has no power .....	50
Impact rate slows down .....	50
Oil overheats .....	51

**SPECIFICATIONS..... 53**

1. Hammer specifications.....	54
Technical specifications .....	54
Main dimensions E 65, E 65 CITY.....	55
2. Tool specifications .....	56
Tool specifications E 65 .....	56

---

---

---

# OPERATION

---

# **1. FOREWORD**

---

## **1.1 PREFACE**

---

Congratulations on having purchased this product. A properly installed attachment should prove to be a productive machine requiring maintenance only at regular intervals.

## **1.2 THIS MANUAL**

---

This manual is arranged to give you a good understanding of the equipment and its safe operation. It also contains maintenance information and technical specifications. Read this manual from front to back before installing, operating or maintaining the attachment for the first time.

In this manual, the units of measurement are metric. For example, weights are given in kilograms (kg). In some cases the other unit follows in parenthesis (). For example 28 litres (7.4 US gal).

The specifications and designs presented in this manual are subject to change without prior notice.

### **SYMBOLS USED IN THIS MANUAL**

This symbol identifies important safety messages within this manual. Carefully read the message that follows. Failure to understand and obey this safety warning could result in injury to you or others, and could also cause damage to equipment. See illustration 1.

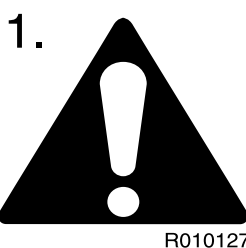

This symbol identifies prohibited action or hazardous location. Failure to understand and obey this safety warning could result in injury to you or others, and could also cause damage to equipment. See illustration 2.

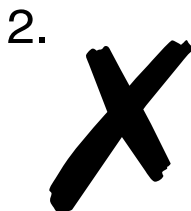

R010128

This symbol identifies correct and recommended action. See illustration 3.

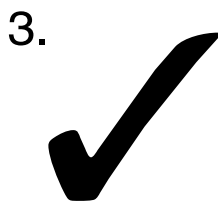

R010126

### **1.3 IMPORTANT SAFETY INFORMATION**

---

Basic safety precautions are outlined in the "Safety" section of this manual and in the description of operations where hazards exist. Warning labels have also been put on the machine to provide instructions and to identify specific hazards which if not observed could cause bodily injury or death to you or other persons. These warnings in the guide and on the machine labels are identified by the warning symbol.

To use the attachment correctly, you must also be a competent operator of the carrier machine. Do not use or install it if you can not use the carrier machine properly. The attachment is a powerful tool. If used without proper care, it can cause damage.

Do not rush when you are learning to use the product. Take your time and most importantly, take it safely. Do not guess. If there is anything you do not understand, ask your local dealer. He will be pleased to advise you.

Improper operation, lubrication or maintenance of this machine can be dangerous and could result in injury.

Do not operate this machine until you read and understand the instructions in this manual.

Do not perform any lubrication and maintenance on this machine until you read and understand the instructions in this manual.

### 1.4 WARRANTY

---

The customer is provided with a separate warranty sheet, where the export warranty terms are explained. Check always that this warranty sheet is provided with the attachment. If not, contact your local dealer immediately.

#### WARRANTY REGISTRATION CARD

A warranty registration card is filled out after the installation inspection by the dealer and a copy of it is sent to the manufacturer. This card is very important because no warranty claims are handled without it. Make sure that you get a copy of it after the installation inspection and that it is correctly filled out.

#### INSTALLATION INSPECTION

An installation inspection must be carried out after the product has been installed on the carrier. In the installation inspection certain specifications (operating pressure, oil flow, etc.) are checked so that they are within given limits.

### 1.5 SPARE PART ORDERS

---

When you need spare parts or some information concerning maintenance to your machinery, please contact your local dealer. Quick deliveries are ensured by exact orders.

Required information:

1. Name of customer, contact person
2. Order number (when available)
3. Delivery address
4. Mode of delivery (air mail, etc.)
5. Required delivery date
6. Invoicing address
7. Model and serial number of product
8. Name, number and required amount of spare parts

## 2. MACHINE NUMBERS

### 2.1 MODEL AND SERIAL NUMBER

The equipment serial number is stamped on the valve body. The model and serial number are also located on the CE marking. Check that the model corresponds to the one given on the cover of this manual.

It is important to make correct reference to the serial number of the attachment when making repairs or ordering spare parts. Identification of the serial number is the only proper means of maintaining and identifying parts for a specific product.

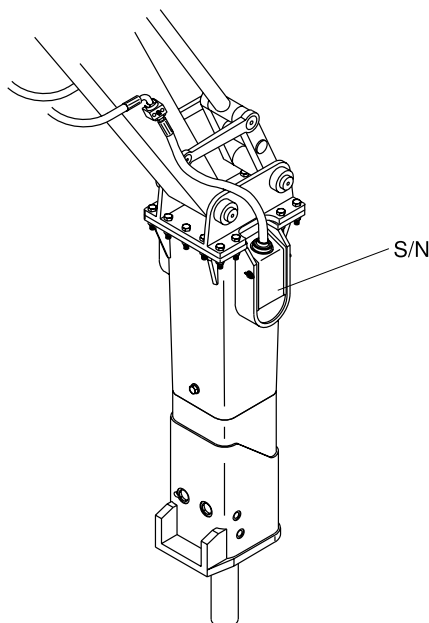

<b>Ram mer</b>	SANDVIK TAMROCK CORP., BREAKERS LAHTI, FINLAND MANUFACTURING YEAR 200X	
	S/N	_____
MODEL	_____	
<b>CE</b>	_____	kg
	_____	l/min
	_____	MPa

R010001

## **3. PRODUCT INTRODUCTION**

---

### **3.1 OVERVIEW**

---

The product is a hydraulically operated breaker. It can be used on any carrier which meets the necessary hydraulic and mechanical installation requirements. The unit functions by repeatedly raising a steel piston and driving it down onto the head of a removable breaking tool.

No additional pressure accumulators are necessary since the integrated pressure accumulator absorbs hydraulic pressure peaks. The impact energy of the hammer is almost constant and independent of the carrier's hydraulic system.

### **3.2 REMOVAL FROM PACKAGE**

---

Remove all the steel belts from the package. Open the package and remove all plastics covering the product. Recycle all package materials (steel, plastic, wood) properly.

Check that the product is in good condition and that there is no visible damage. Check that all ordered parts and accessories have been enclosed with the product. Some options may be provided by your local dealer like installation kits; including hoses and mounting bracket.

### **3.3 LIFTING INSTRUCTIONS**

---

Use a hoist when lifting components which weigh 23 kg (50 lb) or more, to avoid back injury. Make sure all chains, hooks, slings etc., are in good condition and are in the correct capacity. Be sure hooks are positioned correctly. Lifting eyes are not to be side loaded during a lifting operation. Do not use the hammer's tools for lifting.

Lifting devices must safely carry the working weight of the product. See "Hammer specifications" on page 54. Place chains or slings, as shown by the illustration, to lift the product.



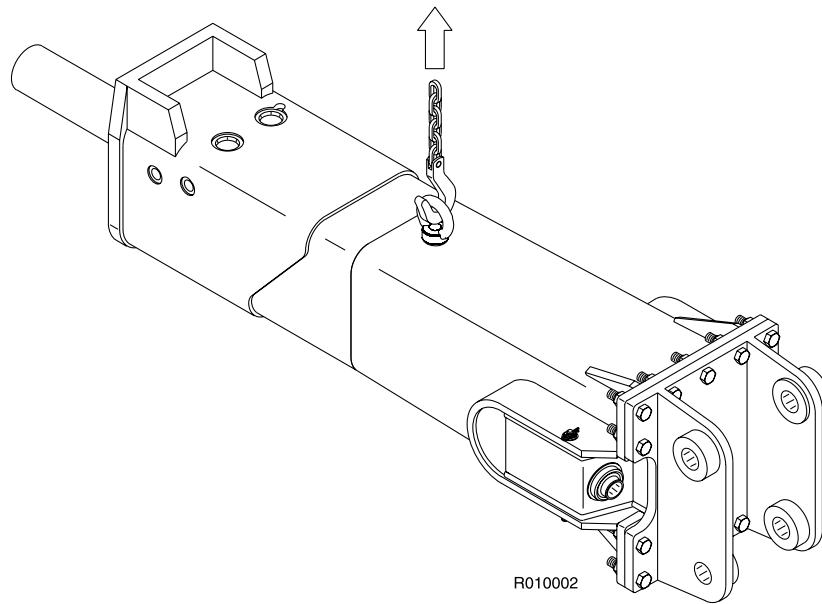

Note: The lifting eye must always be removed from the hammer and replaced with a blanking screw before starting to operate hammer.

### 3.4 MAIN PARTS

The main parts of the hammer are shown below.

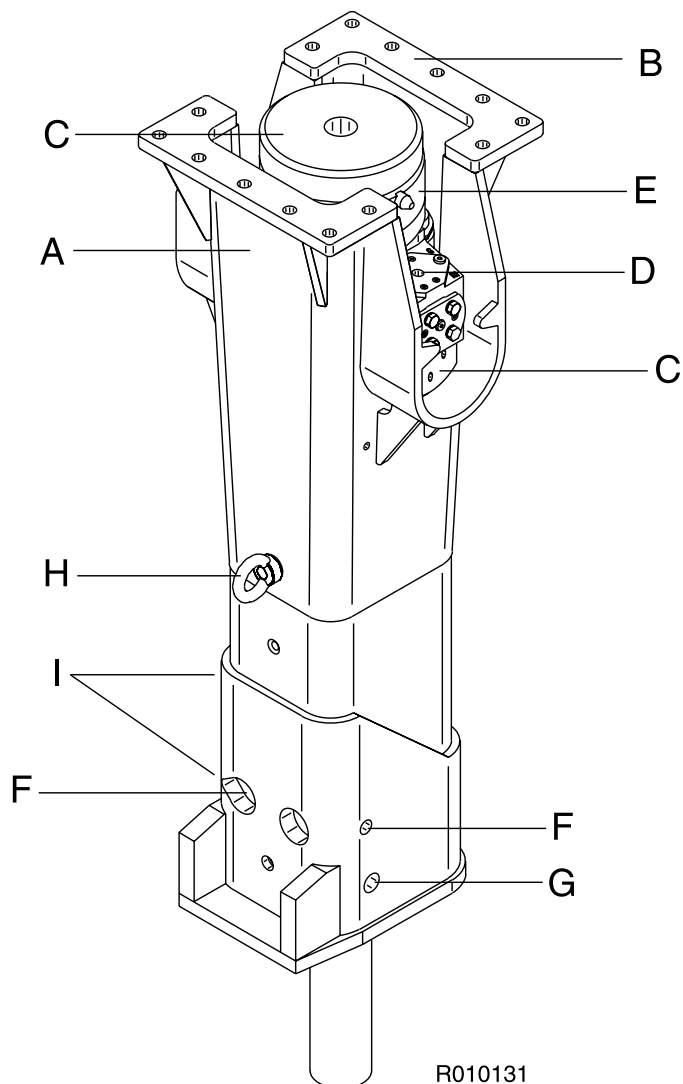

- A. Housing
- B. Mounting flange
- C. Vibration dampening elements
- D. Hose connections (pressure and return lines, automatic lubrication and pressurized air)
- E. Pressure accumulator
- F. Tool retaining mechanism
- G. Tool bushing retaining mechanism
- H. Lifting eye
- I. Grease nipples

---

## 4. SAFETY

---

### 4.1 GENERAL SAFETY

---

All mechanical equipment can be hazardous if operated without due care or correct maintenance. Most accidents involving machine operation and maintenance are caused by failure to observe basic safety rules or precautions. An accident can often be avoided by recognizing potentially hazardous situations before an accident occurs.

Because it is impossible to anticipate every possible circumstance that might involve a potential hazard, the warnings in this guide and on the machine are not all inclusive. If a procedure, tool, working method or operating technique not specifically recommended by manufacturer is used, you must satisfy yourself that it is safe for you and others. You should also ensure that the product will not be damaged or made unsafe by the method of operation or maintenance procedures you choose.

Safety is not just a matter of responding to the warnings. All the time you are working with your attachment you must pay attention to what hazards there might be and how to avoid them. Do not work with the product until you are sure that you control it. Do not start any job until you are sure that you and those around you will be safe.



**Warning! Read the following warning messages carefully. They tell you of different hazards and how to avoid them. If proper precautions are not taken you or others could be seriously injured.**

### 4.2 SAFETY INSTRUCTIONS

---

#### MANUALS

Study this manual before installing, operating or maintaining the product. If there is anything you don't understand, ask your employer or your local dealer to explain it. Keep this manual clean and in good condition.

Study also the operating and maintenance manual of your carrier before operating the attachment.

#### CARE AND ALERTNESS

All the time you are working with the product, take care and stay alert. Always be careful. Always be alert for hazards. The possibility of a serious or even fatal accident is increased when you are intoxicated.

### **CLOTHING**

You can be injured if you do not wear proper clothing. Loose clothing can get caught in the machinery. Wear protective clothing to suit the job.

Examples are: a safety helmet, safety shoes, safety glasses, well-fitting overalls, ear-protectors and industrial gloves. Keep cuffs fastened. Do not wear a necktie or scarf. Keep long hair restrained.

### **PRACTICE**

You and others can be killed or injured if you perform unfamiliar operations without practising them first. Practice away from the job site, in a clear area.

Keep other people away. Do not perform new operations until you are sure you can do them safely.

### **REGULATIONS AND LAWS**

Obey all laws, work site and local regulations which affect you and your equipment.

### **COMMUNICATIONS**

Bad communications can cause accidents. Keep people around you informed of what you will be doing. If you will be working with other people make sure they understand any hand signals you will be using.

Work sites can be noisy. Do not rely only on spoken commands.

### **WORK SITE**

Work sites can be hazardous. Inspect the site before working on it.

Check for potholes, weak ground, hidden rocks etc. Check for utilities (electric cables, gas and water pipes etc.). Mark the positions of underground cables and pipes if you will be breaking the ground.

Poor visibility can cause accidents and damage. Make sure that visibility and lighting of the working area are adequate.

### **BANKS AND TRENCHES**

Banked material and trenches can collapse. Do not work too close to banks and trenches where there is a danger of collapse.

### **SAFETY BARRIERS**

Unguarded equipment in public places can be dangerous. Place barriers around the machine to keep people away.

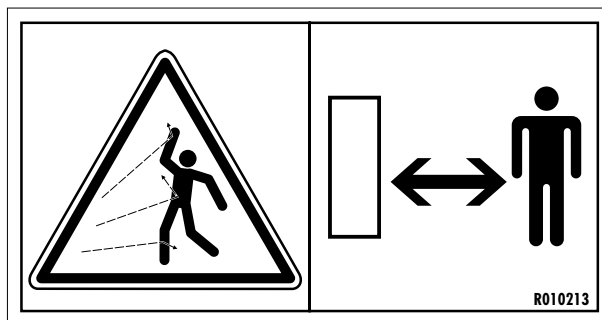
**FLYING CHIPS OF ROCK**

Protect yourself and your neighbourhood against flying chips of rock. Do not operate the product or carrier if someone is too close.

Keep the cabin windows and doors closed during operation. Window bars are recommended to protect the windows from flying chips of rock.

**HIGH NOISE LEVEL**

High noise level. Wear ear protection to prevent personal injury.

**EQUIPMENT LIMITS**

Operating the product beyond its design limits can cause damage. It can also be dangerous. See “Hammer specifications” on page 54.

Do not try to enhance the product's performance by unapproved modifications.

**HYDRAULIC FLUID**

Fine jets of hydraulic fluid at high pressure can penetrate the skin. Do not use your fingers to check for hydraulic fluid leaks. Do not put your face close to suspected leaks. Hold a piece of cardboard close to suspected leaks and then inspect the cardboard for signs of hydraulic fluid. If hydraulic fluid penetrates your skin seek medical help immediately.

Hot hydraulic fluid can cause severe injuries.

### HYDRAULIC HOSES AND FITTINGS

Ensure all hydraulic components will withstand maximum pressure and mechanical stresses caused by operation of the attachment. Consult your local dealer for instructions.

### FIRE HAZARD

Most hydraulic fluids are flammable and might ignite when contacting hot surface. Avoid spilling hydraulic fluid to hot surfaces.

Working with the product on certain materials can cause sparks and hot splinters to get loose. These can ignite flammable materials around working area.

Ensure that adequate extinguisher is available.

### HYDRAULIC PRESSURE

Hydraulic fluid at system pressure can injure you. Before disconnecting or connecting hydraulic hoses, stop the carrier engine, operate the controls to release pressure trapped in the hoses and wait ten (10) minutes. During the operation, keep people away from the hydraulic hoses.

There might be pressurized oil trapped inside the product even if it is disconnected from the carrier. Be aware of possible blank firing while greasing or removing and installing hammer tools. See “Removal of tool” on page 43.

### PRESSURE ACCUMULATORS

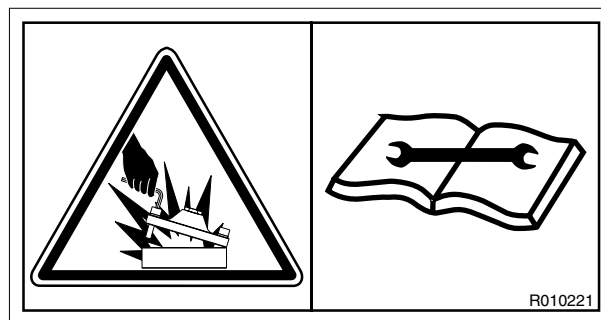

The hammer incorporates one or two pressure accumulators, depending on the model. The accumulators are pressurized even when there is no hydraulic pressure to the hammer. Attempting to dismantle the accumulators without first releasing the pressure can cause injury or death. Do not try to dismantle pressure accumulators, contact your local dealer first.

**LIFTING EQUIPMENT**

You can be injured if you use faulty lifting equipment. Make sure that lifting equipment is in good condition. Make sure that the lifting tackle complies with all local regulations and is suitable for the job. Make sure that the lifting equipment is strong enough for the job and you know how to use it.

Do not use this product or any of its parts for lifting. See “Lifting instructions” on page 8. Contact your carrier dealer to find out how to lift with your carrier.

**SPARE PARTS**

Use only genuine spare parts. Use only genuine tools with hydraulic hammers. The use of other spare part or hammer tool brands may damage the product.

**EQUIPMENT CONDITION**

Defective equipment can injure you or others. Do not operate equipment which is defective or has missing parts.

Make sure the maintenance procedures in this manual are completed before using the product.

**REPAIRS AND MAINTENANCE**

Do not try to do repairs or any other maintenance work you do not understand.

**MODIFICATIONS AND WELDING**

Non-approved modifications can cause injury and damage. Contact your local dealer for advice before modifying the product. Before welding on the product while it is installed on the carrier, disconnect the carrier alternator and battery. Note that welding of the hammer tools will render them useless and make the warranty void.

**METAL SPLINTERS**

You can be injured by flying splinters when driving metal pins in and out. Use soft-faced hammer or drifts to remove and fit metal pins, such as pivot pins. Always wear safety glasses.

## 5. OPTIONAL EQUIPMENT

---

### 5.1 RAMLUBE

---

Lubrication of the tool and the tool bushings of the hammer can be made automatically by equipping the carrier with a lubrication pump. The tool grease is supplied from the pump into the hammer by hose. During operation, grease holder must be filled with suitable tool grease. Adjust pump output to working conditions.

Advantages of the automatic lubrication system are:

- Longer service life for wear parts
- Higher utilization rate of the hammer
- Possibility to grease manually
- Grease waste reduced

The latest hammer models are equipped with a built-in automatic lubrication system connection point, from where the tool grease is fed along an internal channel to the tool bushing and the tool shank.



---

## 6. OPERATION

---

### 6.1 OPERATING INSTRUCTIONS

---

#### RECOMMENDED USE

The hammer is designed to be used in breaking concrete, road surface or asphalt, hard or frozen ground. It can be also used in breaking moderate sized boulders as well as in demolishing reinforced structures and for major excavation and clearing work. Your local dealer will gladly give you more information.

#### OPERATING CONDITIONS

##### *Principle of installation*

Almost all carriers meeting mechanical and hydraulic requirements can be used to operate the attachment. See “Hammer specifications” on page 54. The product is installed on the carrier much in the same manner as installing a bucket or other attachments. A top mounted attachment requires a separate mounting bracket.

The attachment is connected to a carrier's hydraulic circuit with an installation kit. If the carrier is already equipped with an installation kit, the installation requires only suitable hoses and fittings. If the carrier does not have suitable kit to run the attachment, one must be built. This may require more complex installation including new piping and additional valves such as directional valve and pressure relief valve.

Suitable kits can be ordered from the manufacturer or local dealers, from carrier manufacturers and their dealers or from third party suppliers.

##### *Hydraulic oil*

In general the hydraulic oil originally intended for the carrier can be used with this product. See “Requirements for hydraulic oil” on page 34.

##### *Operating temperature*

The operating temperature is -20 °C to +80 °C (-4 °F to +176 °F). If the temperature is lower than -20 °C (-4 °F), the hammer and tool have to be preheated before any operations can begin, in order to avoid breaking the accumulator's membrane and the tool. During operation they will remain warm.

Note: The temperature of the hydraulic oil must be monitored. Ensure that oil grade and monitored oil temperature together guarantee correct oil viscosity. See “Oil specifications” on page 35.

### *Noise dampening*

Operating the hammer near residential areas or other noise sensitive areas can cause noise pollution. In order to avoid unnecessary noise, please follow these basic rules:

1. When operating with the hammer, keep the tool at 90 degree angle to the material and the feed force in-line with the tool.
2. Replace or fix all parts that are worn out, damaged or loosened. This not only saves your hammer but it decreases the noise level.



Silenced CITY models are ideally suited for breaking in urban areas.

### **PRINCIPLES OF BREAKING**

To increase the hammer's working life, pay particular attention to correct working methods and how to choose the correct tool for the job. There are essentially two ways of breaking with a hydraulic hammer.

#### *Penetrative breaking (or cutting)*

In this form of breaking a moil point or chisel tool is forced inside the material. This method is most effective in soft, layered or plastic, low abrasive material. The high impact rate of the small hammers makes them ideal for penetrative breaking.

#### *Impact breaking*

With impact breaking, the material is broken by transferring very strong mechanical stress waves from the tool into the material. The best possible energy transfer between the tool and the object is achieved with a blunt tool. Impact breaking is most effective in hard, brittle and very abrasive materials. The use of a chisel tool in hard material will cause the sharp edge to wear very quickly. The high impact energy of the big hammers makes them ideal for impact breaking.

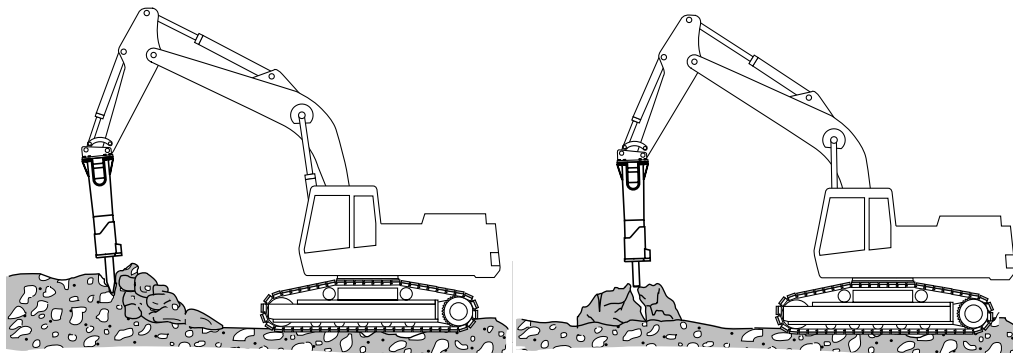

R010007

## **CHOOSING TOOLS**

A selection of standard and special tools to suit each application are available. The correct type of tool must be selected to get the best possible working results and longest life time for the tool. Choosing the best tool type for an application may require some testing, please consult with your local dealer. See “Tool specifications” on page 56.

### ***Chisel, moil point and pyramid***

- For sedimentary (e.g. sandstone) and weak metamorphic rock into which the tool penetrates.
- Concrete.
- Trenching and benching.

### ***Blunt tool***

- For igneous (e.g. granite) and tough metamorphic rock (e.g. gneiss) into which the tool doesn't penetrate.
- Concrete.
- Breaking boulders.

It is important to choose a tool, which is suitable for your hammer and for the application you are working on. The tool selection available depend on hammer model. See “Tool specifications” on page 56.

## 6.2 DAILY OPERATION



**Warning! Protect yourself and your neighbourhood against flying chips of rock. Do not operate the hammer or carrier if someone is too close to the hammer.**

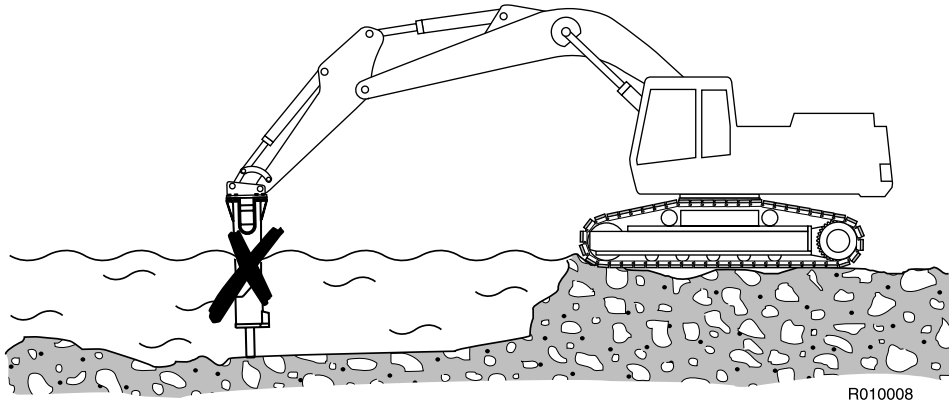

**The hammer as a standard assembly, must not be used under water. If water fills the space where the piston strikes the tool, a strong pressure wave is generated and the hammer may be damaged.**

1. Prepare the carrier for normal excavation work. Move the carrier to the required position. Set the drive to neutral.
2. Set the engine speed to the recommended engine RPM for correct amount of oil supply.
3. Carefully operate the carrier controls to place the hammer and boom into the breaking position. Quick and careless boom movements could result in damage to the hammer.

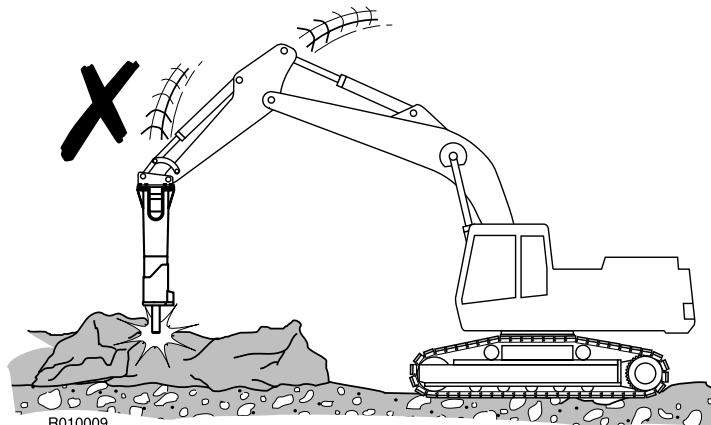

- Use the excavator boom to press the hammer firmly against the object. Do not pry the hammer with the boom. Do not press too hard or too gently with the boom. The correct force is applied, when the tracks start to lift slightly from the ground.

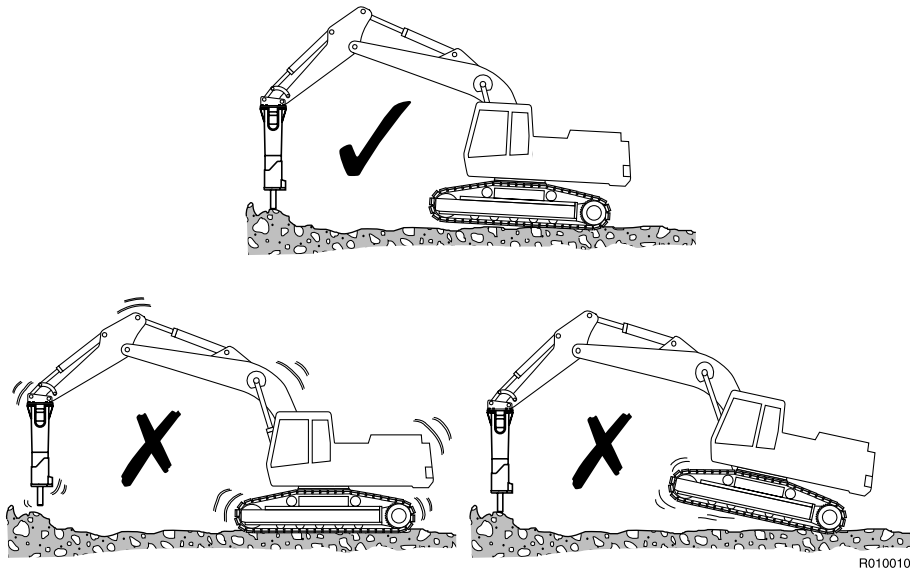

- Place the tool against the object at a 90 degree angle. Avoid small irregularities on the object which will break easily and cause either idle strokes or an incorrect working angle.

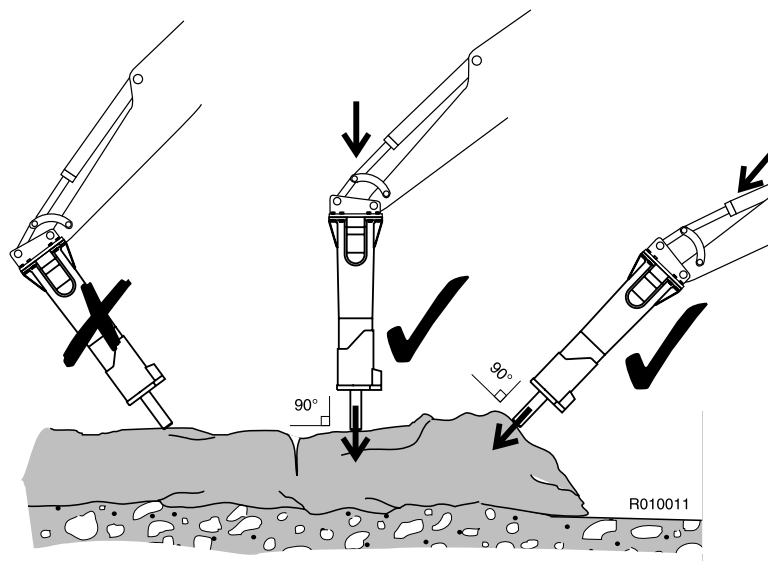

- When demolishing vertical structures (e.g. brick walls), place the tool against the wall at a 90 degree angle.

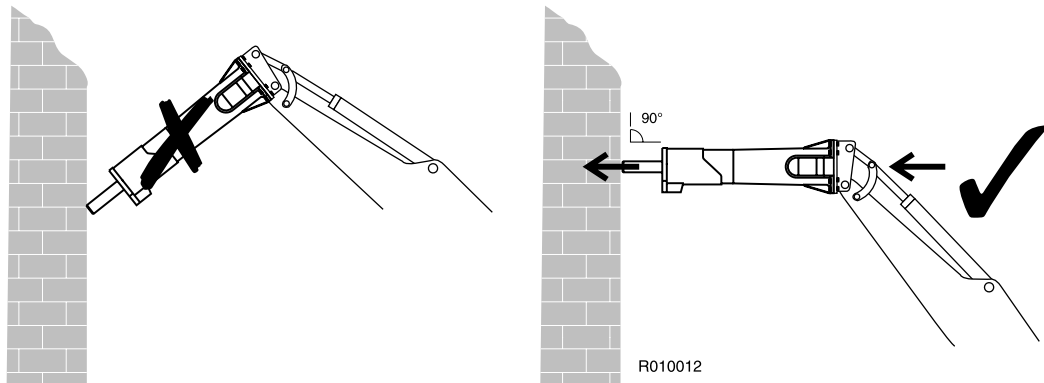

- Start the hammer.
- A safety screen is recommended to protect the operator from flying debris. Keep the cabin windows and doors closed during operation.

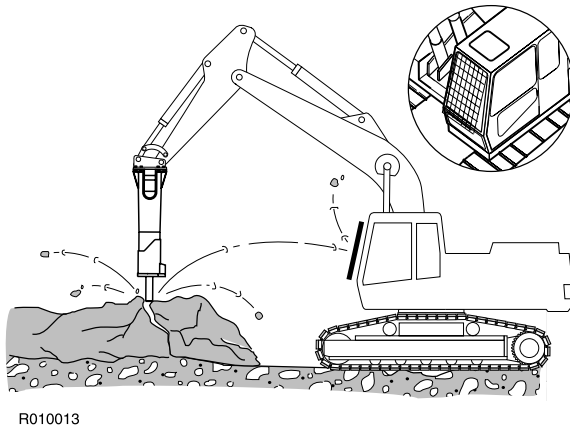

- Note: Listen to the hammer's sound when you are using it. If the sound becomes weaker and the impact less efficient, the tool is misaligned with the material and/or there is not enough down force on the tool. Realign the tool and press the tool firmly against the material.

10. Do not strike in one spot for more than 15 seconds at a time. If the object does not break, or if the tool does not penetrate, stop the hammer and change the position of the tool. Working too long in one spot will create stone dust under the tool. Dust dampens the impact effect and produces heat.

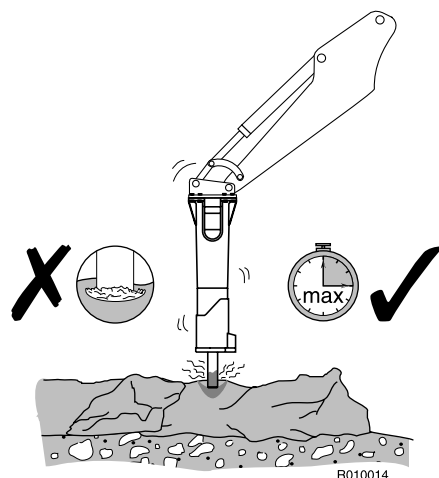

11. Do not let the tool move outwards from the hammer when it penetrates. Keep the down-pressure on the hammer while breaking.
12. To use the hammer most efficiently when breaking big boulders, concentrate on small steps from the outer edge towards the middle.

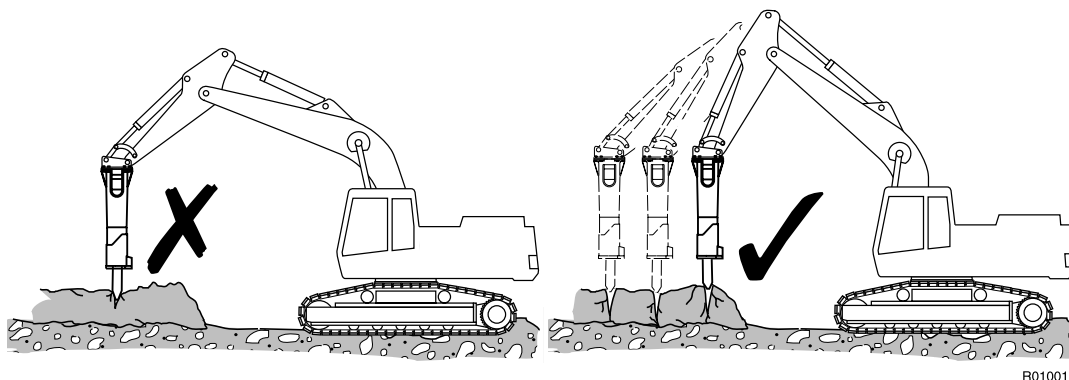

13. When breaking hard or frozen ground, use the benching method. Start with clearing a small area from the edge. Then continue by breaking material towards the open area.

14. Stop the hammer quickly. Do not allow the hammer to fall down and make idle strokes when an object breaks. Frequent idle strokes have a deteriorating effect on the hammer. If the hammer falls through, the housing wears out more quickly.

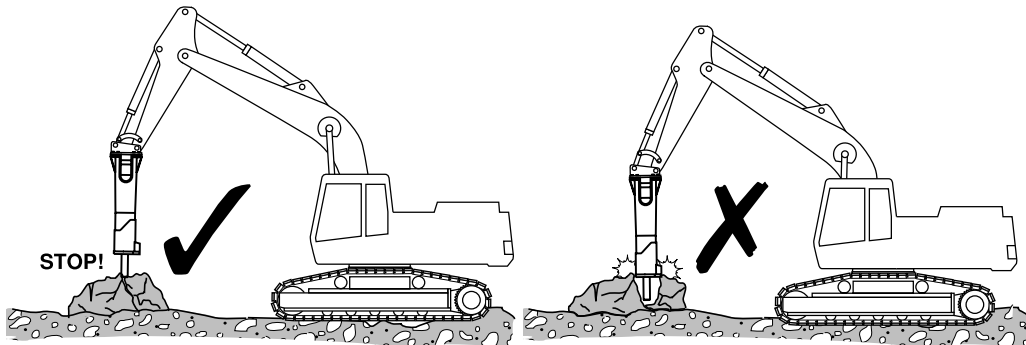

R010016

15. When breaking concrete, hard or frozen ground, never strike and pry with the tool at the same time. The tool may break. Bending may be caused by stones inside hard or frozen ground. Be careful and stop striking if you find sudden resistance under the tool.

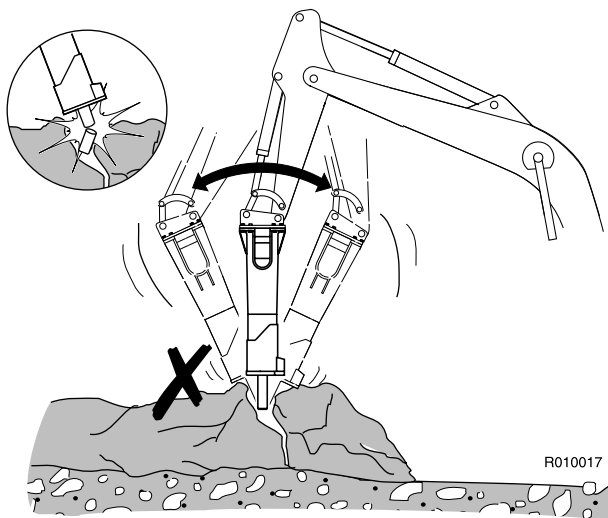

R010017

16. Keep the tool at a 90 degree angle at all times. If the object moves or its surface breaks, correct the angle immediately. Keep the feed force and tool aligned.



17. Do not use the hammer tools to move rocks. The stone claws are designed for this purposes.

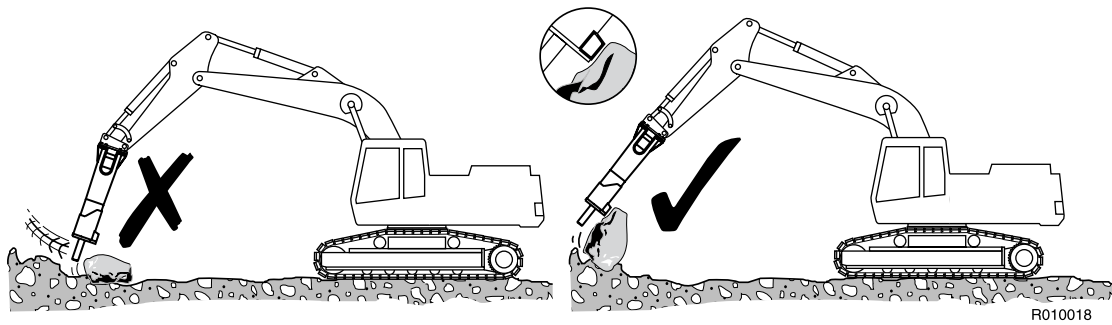

18. Do not use the hammer to sweep the ground of debris. This may damage the hammer and the housing will wear out more quickly.

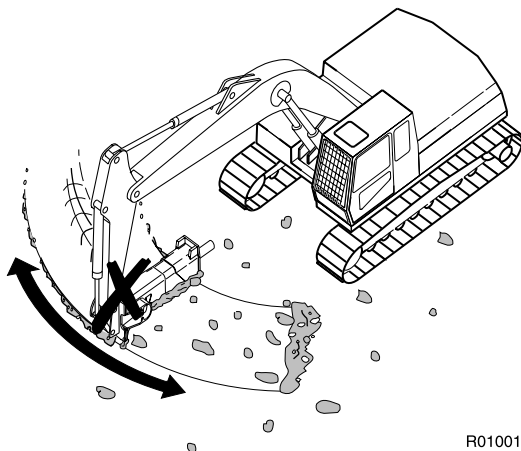

19. When operating the hammer, make sure that it does not make contact with the carrier boom or hydraulic lines.

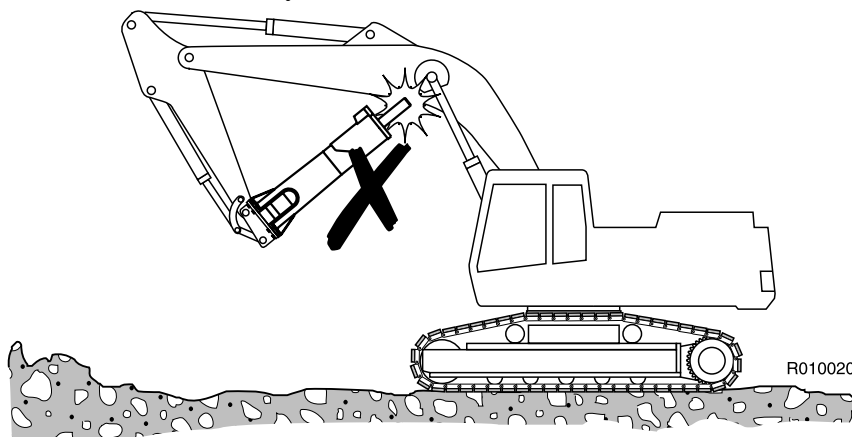

20. Do not operate the hammer with the carrier's boom, stick or bucket cylinders at the end of their stroke (either fully extended or fully retracted). Damage to the carrier may result.

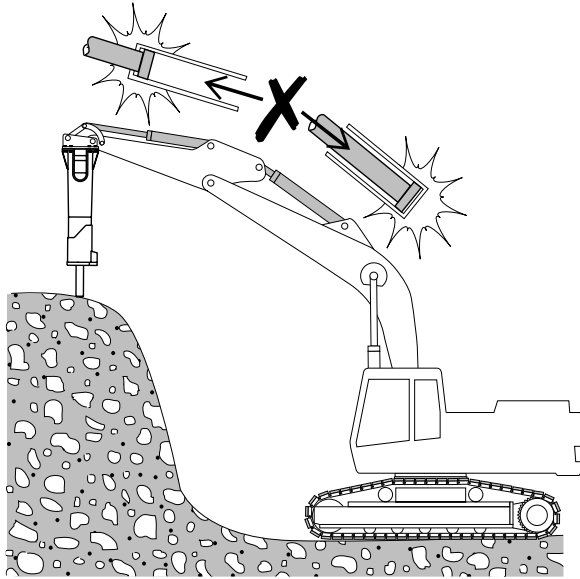

R010021

21. Do not use the hammer or hammer tools for lifting. Lifting eyes on the hammer are for storage and maintenance purposes only.

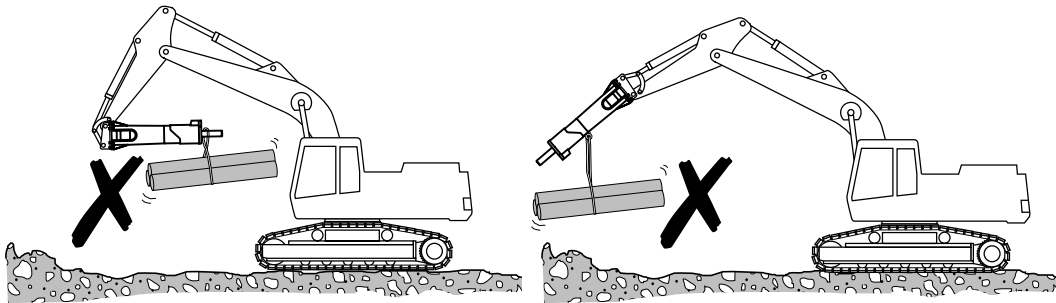

R010022

22. The tool shank must be well greased during operation. Regular visual inspections during operation are recommended. An unlubricated tool shank requires more frequent greasing intervals. A tool shank covered with excessive grease requires less frequent greasing intervals.

R010023

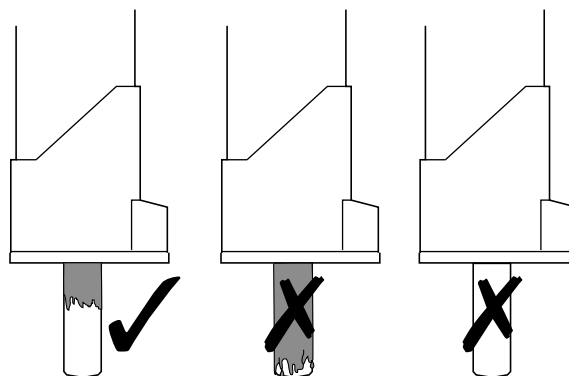

## 6.3 MOUNTING AND DISMOUNTING THE HAMMER

### REMOVAL FROM CARRIER



**Warning!** The hammer must be secured from rolling over when disconnecting from the carrier. Only use skilled operator to position carrier for hammer removal!

**Warning!** Hydraulic pressure inside hammer must always be released before opening hose connections!

**Warning!** Hot hydraulic fluid can cause severe injuries!

1. Position hammer horizontally on the floor and remove the tool.
2. Stop the carrier engine. Operate boom and hammer controls to release pressure trapped inside hoses. Wait ten minutes for oil pressure to drop.
3. Close hammer inlet and outlet lines. If quick couplers are used, disconnection automatically closes hammer lines. If hammer line includes ball valves, please make sure that they are closed.
4. Disconnect hoses. Plug the hoses and the hammer inlet and outlet ports.
5. Remove bucket pins and other parts.

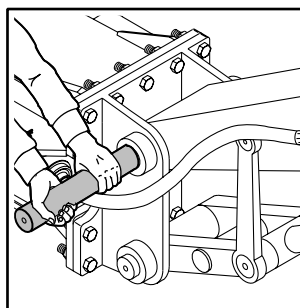
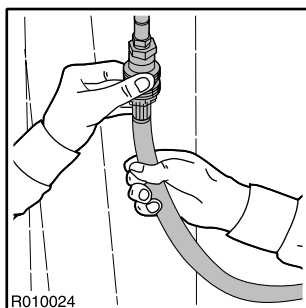

6. The carrier can be moved aside.

### INSTALLATION

1. Install hammer in the same manner as mounting a bucket. Install bucket pins.
2. Connect hoses. Hammer inlet port is marked on the valve body with "IN" and outlet port with "OUT".
3. Open hammer inlet and outlet lines.

### 6.4 MOVEMENT

---

The transportation and parking positions are shown below. When moving with the hammer, ensure that it isn't too close and doesn't point at the cabin window.

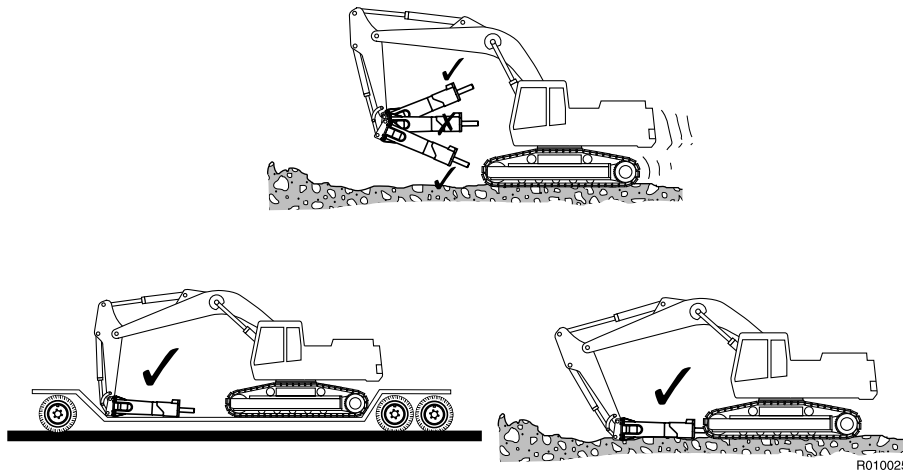

### 6.5 SPECIAL CONDITIONS OF USE

---

If hammer is to be used in conditions that differ from normal breaking or demolition work conditions, such as:

- Hammer tunnelling
- Foundry cleaning
- Underwater operations
- Operations in extremely low or high temperatures
- Use of special hydraulic fluids
- Hammer operations with special carrier (extra long boom etc.)
- Other special conditions

That may require modifications to attachment, special operating techniques, increased maintenance or special wear items.

In case of special conditions of use, please consult your local dealer for instructions.

#### UNDERWATER OPERATION

The latest hammer models can be modified for underwater operations for only short periods. The operating principle in underwater hammering is to conduct pressurized air through a built-in channel to the spaces above and below the piston. The air pressure prevents water entering the hammer. The hammer as a standard assembly, must not be used under water. If water fills the space where the piston strikes the tool, a strong pressure wave is generated and the hammer may be damaged.

The wear resistance of the hammer parts is considerably lower under water than in normal use. This is caused by corrosion and by the abrasive effect of mud in water. After starting underwater hammering, the hammer must be inspected regularly, for example after every half hour operation. Adapt the inspection intervals to the working conditions. See “Maintenance intervals in underwater use” on page 42.

In underwater applications, the productivity of a hydraulic hammer is considerably lower than in normal work. This is caused by:

1. The breaking object is not visible to the operator. This causes misalignment between the tool and the object and unnecessary idle strokes.
2. The hammer must be inspected and greased more often than in normal situations.
3. The hammer must always be completely serviced after working on underwater job sites.



**The hammer as a standard assembly, must not be used under water. If water fills the space where the piston strikes the tool, a strong pressure wave is generated and the hammer may be damaged.**

## **6.6 STORAGE**

---

### **LONG TERM STORAGE**

Observe the following points when the hammer is stored. In this way the vital parts of the attachment are protected from rust and the machine is ready to be used whenever necessary.

1. The storage area must be dry.
2. The tool must be removed in hydraulic hammers.
3. The lower end of the piston, tool and tool bushings must be well protected with grease in all hydraulic hammers.
4. Connections must be sealed with clean plugs to prevent oil leakage and dirt from getting into couplings.
5. The product must be stored in the vertical position.
6. Make sure the product can not fall.



---

---

# LUBRICATION

---

# 1. HAMMER TOOL GREASING

---

## 1.1 RECOMMENDED GREASES

---

- RAMMER TOOL GREASE, part no. 902045
- FUCHS Meisselpaste
- KENDALL Tough TAC
- KLÜBER Crafloscon C-SG 0 Ultra
- LE 3751/3752 Almagard varipurpose lubricant
- SHELL Kuggfett
- SHELL Albida HLS 2
- WYNNS GS80

## 1.2 MANUAL GREASING

---

### GREASING INTERVAL

1. Tool shank must be well lubricated before installing tool.
2. 5-10 strokes from grease gun to tool bushings and tool at regular intervals.
3. Adapt interval and amount of grease to wear rate of tool and working conditions. This can be anything between two hours and daily, depending on material (rock/concrete) to be broken. See “Recommended greases” on page 32.

Insufficient greasing or improper grease may cause:

- Abnormal wear of tool bushing and tool
- Tool breakage

### CORRECT GREASING

1. Position the hammer standing upright resting on the tool on firm surface.
2. Stop carrier engine and wait 10 minutes for oil pressure to drop inside hammer.



3. Apply tool grease from grease gun to greasing points marked with the following sticker.

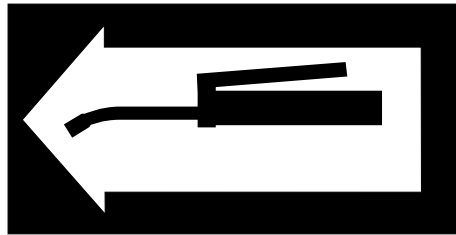

R020002

Note: The hammer must stand upright resting on the tool to ensure that the grease will penetrate downwards between the tool and the bushing.

Do not fill the space between the piston and the tool with grease. A lower piston seal failure can result and the hammer will subsequently leak oil.

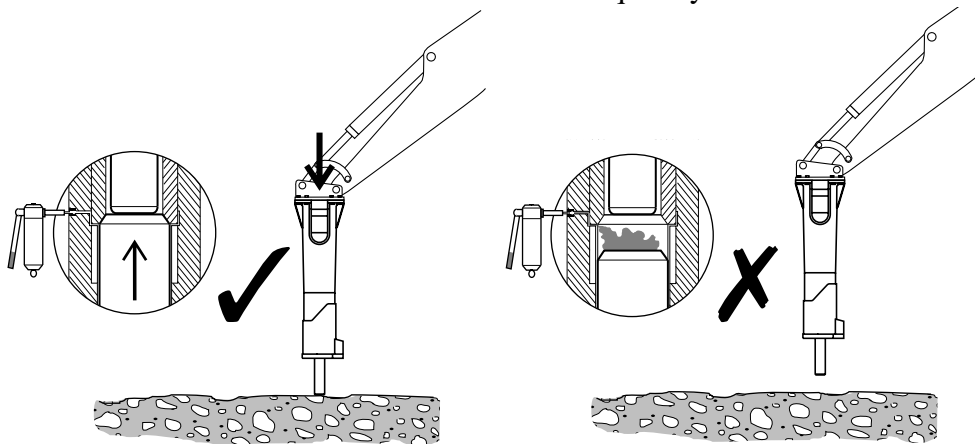

R020001

### 1.3 AUTOMATIC LUBRICATION

The hammer can be equipped with an automatic lubrication device. For more information consult your local dealer. See “Ramlube” on page 16.

## 2. CARRIER HYDRAULIC OIL

---

### 2.1 REQUIREMENTS FOR HYDRAULIC OIL

---

#### GENERAL REQUIREMENTS

In general the hydraulic oil originally intended for the carrier can be used with this product. However, since working with the product heats the oil more than the usual excavation work, the temperature of the oil must be monitored.

If the temperature of the hydraulic oil exceeds 80 °C, an auxiliary oil cooler is needed. The oil viscosity must be between 1000-20 cSt while the attachment is being used.

When the product is used continuously, the temperature of the hydraulic oil normalizes at a certain level depending on conditions and on the carrier. The temperature in the tank must not exceed the maximum allowed.

The hammer must not be started if the ambient temperature is below freezing and the oil is very thick. The machine must be moved to bring the oil temperature above 0 °C before hammering can start (viscosity 1000 cSt or 131 °E).

**OIL SPECIFICATIONS**

Table below shows hydraulic oils recommended for hammer use. The most suitable oil is selected in such a way that the temperature of the hydraulic oil in continuous use is in the ideal area on the chart and the hydraulic system is used to best advantage.

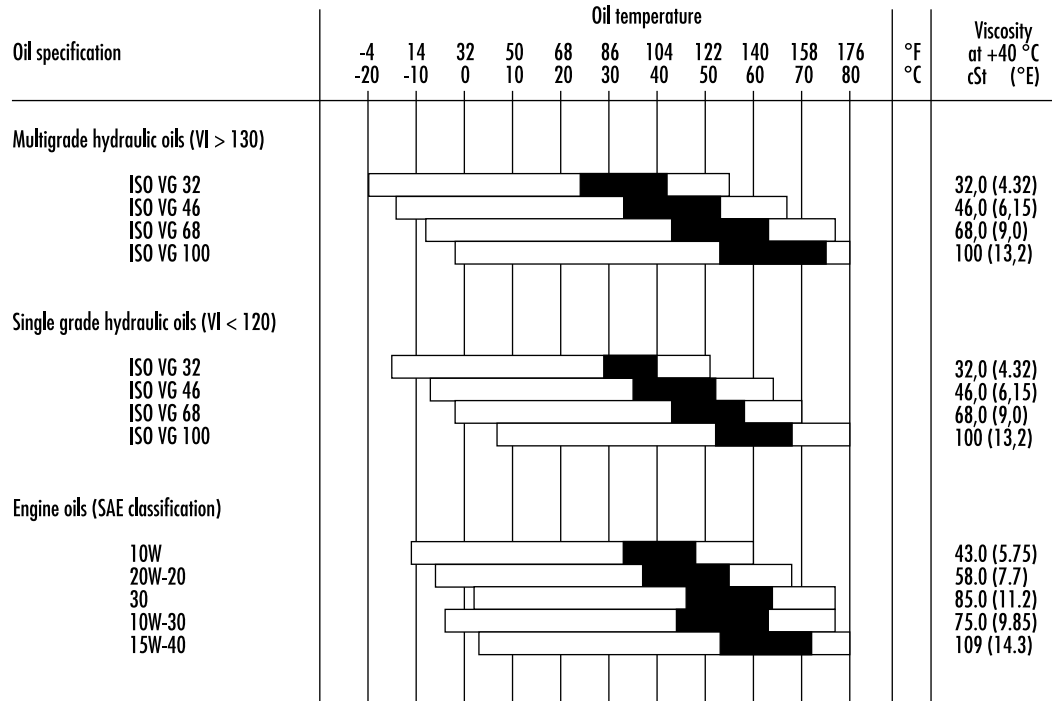

VI = Viscosity index  
 □ Permitted oil temperature  
 ■ Recommended oil temperature

R020004

Problems due to incorrect hydraulic oil viscosity in the hammer:

***Oil too thick***

- Difficult start up
- Stiff operation
- Hammer strikes slowly
- Danger of cavitation in pumps and in the hydraulic hammer
- Sticky valves
- Filter bypass opens, impurities in the oil are not removed

### *Oil too thin*

- Efficiency losses (internal leaks)
- Damage to gaskets and seals, leaks
- Accelerated wearing of parts, because of decreased lubrication efficiency
- Hammer strikes irregularly and slowly
- Danger of cavitation in pumps and in the hydraulic hammer

Note: We strongly recommend the use of different hydraulic oils in the summer and in the winter if there is an average temperature difference of more than 35 °C. The correct hydraulic oil viscosity is thus ensured.

### **SPECIAL OILS**

In some cases special oils (e.g. biological oils and non-inflammable oils) can be used with the hydraulic hammers. Observe the following aspects when considering the use of special oils:

- The viscosity range in the special oil must be in the given range (20-1000 cSt)
- The lubrication properties must be sufficient
- The corrosion resistance properties must be good enough

Note: Although a special oil could be used in the carrier, always check its suitability with the hammer due to high piston speed of the hammer. Contact the oil manufacturer or your local dealer for more information about special oils.

## **2.2 OIL COOLER**

---

The correct place to connect the hammer return line is between the oil cooler and the main filters. The hammer return line should not be connected before the oil cooler. Routing the hammer return flow through the cooler, might damage either the cooler, due to pulsating flow, or the hammer, due to increased back pressure.

The carrier hydraulic system must be able to maintain the temperature within an acceptable level during the hammer operation. This is for two reasons.

1. Seals, wipers, membranes and other parts manufactured from the corresponding materials can normally stand temperatures up to 80 °C.
2. The higher the temperature is, the less viscous the oil gets thus losing its capability to lubricate.

A standard carrier, with a proper hammer circuit, meets the requirements of the necessary cooling capacity. If the oil temperature tends to be too high during the hammer operation, the following things must be checked:

- The hammer circuit pressure relief valve is not open when the hammer is operated.
- The hammer circuit pressure drops are reasonable. Less than 10 bar in the pressure line and less than 5 bar in the return line.
- Hydraulic pumps, valves, cylinders, motors etc. and hammer do not have internal leakages.

If all of the above mentioned things are in order, and the temperature of the hydraulic oil still tends to be too high, extra cooling capacity is needed. Consult the carrier manufacturer or dealer for details.

## **2.3 OIL FILTER**

---

The purpose of the oil filter is to remove impurities from the hydraulic oil. Air and water are also impurities in oil. Not all impurities can be seen with the naked eye.

Impurities enter the hydraulic system:

- During hydraulic oil changes and refilling.
- When components are repaired or serviced.
- When the hammer is being installed on the carrier.
- Because of component wear.

Normally the existing main oil filters of the carrier are used as hammer circuit return line filters. Consult the carrier manufacturer or your local dealer concerning instructions for the filter change intervals.

In hydraulic hammer work the carrier oil filter must fulfil the following specifications:

- The oil filter must allow maximum particle size of 25 microns (0.025 mm).
- The oil filter material must be artificial fibre cloth or very fine gauge metallic mesh to withstand pressure fluctuations.
- The oil filter must have a nominal flow capacity of at least twice the hammer's maximum flow.

In general, oil companies guarantee new oils to have a particle count of 40 microns maximum. Filter the oil when filling the tank.

The damage caused by hydraulic oil impurities in the carrier and hammer circuits:

1. The working life of the pumps and other components is significantly shortened.
  - Rapid wear of parts.
  - Cavitation.
2. Wear of cylinder and gaskets.

3. Reduced hammer efficiency.
  - Accelerated wear of moving parts and seals.
  - Danger of piston seizing up.
  - Oil leakages.
4. Shortened working life and reduced lubricating capability of oil.
  - Oil overheats.
  - Oil quality deteriorates.
  - Electro-chemical changes in hydraulic oil.
5. Valves do not function properly.
  - Spools bind.
  - Rapid wear of parts.
  - Blocking of small holes.

Note: Component damage is only a symptom. The trouble itself will not be cured by removing the symptom. After any component damage due to impurities in the oil, the entire hydraulic system has to be cleaned. Dismantle, clean and reassemble the hammer and change the hydraulic oil.

---

---

# **MAINTENANCE**

---

# **1. ROUTINE MAINTENANCE**

---

## **1.1 OVERVIEW**

---

This product is a precision made hydraulic machine. Therefore great care and cleanliness should be taken when handling any of the hydraulic components. Dirt is the worst enemy in hydraulic systems.

Handle the parts carefully and remember to cover any cleaned and dried parts with clean lint-free cloth. Do not use anything other than purpose designed materials for cleaning hydraulic parts. Never use water, paint thinners or carbon tetrachloride.

Components, gaskets and seals in the hydraulic system should be oiled with clean hydraulic oil before assembly.

## **1.2 INSPECTION AND MAINTENANCE BY THE OPERATOR**

---

Note: The times given refer to the carrier hours while the attachment is installed.

### **EVERY TWO HOURS**

- Grease the tool shank and the tool bushings.
- Observe hydraulic oil temperature, all lines and connections as well as impact efficiency and evenness of operation.
- Tighten loose connections.

### **EVERY 10 HOURS OR AT LEAST ONCE A WEEK**

- Remove the tool retaining pin and the tool and check their condition. Grind the burrs away if necessary. See “Removal of tool” on page 43.
- Check that the tool has received sufficient grease. Grease more frequently, if necessary.



**EVERY 50 HOURS OR AT LEAST ONCE A MONTH**

- Check the tool shank and tool bushings for wear. See “Removal of tool” on page 43. See “Lower tool bushing” on page 46.
- Check the hydraulic hoses. Replace if necessary. Do not let dirt get into the hammer or hoses.
- Check that the hammer moves normally inside the housing and that vibration dampening elements (pads and buffers) are in good condition.
- Check the condition of wear plates by moving hammer with a pry bar from side to side inside housing. The maximum allowed clearance is approximately  $\pm 10$  mm.

**1.3 INSPECTION AND MAINTENANCE BY THE DEALER**

---

Note: The times given refer to the carrier hours while the attachment is installed.

**INITIAL 50-H INSPECTION**

It is recommended to have the first inspection done by your local dealer after 50 to 100 operating hours. Contact your local dealer for more information about the initial 50-hour inspection.

**EVERY 600 HOURS OR ONCE A YEAR**

This service is recommended to be done by your local dealer after 600 operating hours. Neglecting the yearly service can cause severe damage to the hammer.

Your local dealer will reseal the hammer, replace the accumulator membranes and replace safety decals as needed. Contact your local dealer for more information about yearly servicing.

During this maintenance you should do the following tasks.

- Check all hydraulic connections.
- Check that the hydraulic hoses do not rub against anything in any boom position.
- Replace and inspect the hydraulic oil filters of the carrier.

**1.4 MAINTENANCE INTERVALS IN SPECIAL APPLICATIONS**

---

The service interval is considerably shorter in special applications. See “Special conditions of use” on page 28. In special applications, please consult your local dealer for the correct service intervals.

### MAINTENANCE INTERVALS IN UNDERWATER USE

#### *After every half hour operation*

- Grease the tool shank and the tool bushings through the grease nipples.
- Check that the hammer moves normally inside the housing and that the buffers are in good condition.
- Check all hoses and connections.
- Check the operation of the air pressure switch.

#### *Daily maintenance*

- Remove the retaining pin and the tool for inspection. Grind the burrs away if necessary.
- Check that the tool has received sufficient grease.
- Service the hammer after underwater jobs.

The hammer must be totally dismantled and serviced after working underwater.

Neglecting a hammer service after underwater work can cause severe damage to the hammer.



**The hammer as a standard assembly, must not be used under water. If water fills the space where the piston strikes the tool, a strong pressure wave is generated and the hammer may be damaged.**

## 1.5 OTHER MAINTENANCE PROCEDURES

---

### WASHING THE ATTACHMENT

When working with attachment and removing it from the carrier, dirt (mud, rock powder etc.) can become attached to it. Wash the outside of the product with a steam washer before sending it to the workshop. Dirt can cause difficulties in disassembly and assembly otherwise.

**CAUTION!** Plug the pressure and return line before washing the product or else dirt can enter into it and this may cause damage to the components.

## 2. REMOVAL OF TOOL

### WEAR LIMITS AND LUBRICANTS FOR TOOL REMOVAL

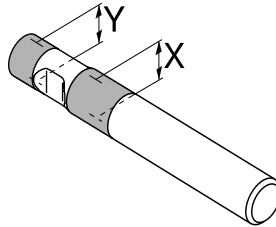

R030045

Item	Wear limit
Tool diameter X (worn out)	123 mm (4.84 in)
Tool diameter Y (worn out)	113 mm (4.45 in)

Item	Lubricant
Tool and tool retaining pins	Tool grease

### REMOVAL OF TOOL



**Warning!** The hydraulic pressure inside the hammer must always be released before removing the tool. After operating the hammer, wait 10 minutes for oil pressure to drop inside hammer.

**Warning!** Hot tool can cause severe injuries.

1. Set the hammer on level ground.
2. Make sure the carrier's transmission is in neutral and the parking brake is engaged.
3. Stop the carrier engine.
4. Push the rubber plate upwards so that the pin holes are accessible.
5. Remove rubber plugs.
6. Knock split pin so far that retaining pin can be removed.

## REMOVAL OF TOOL

7. Remove retaining pin.

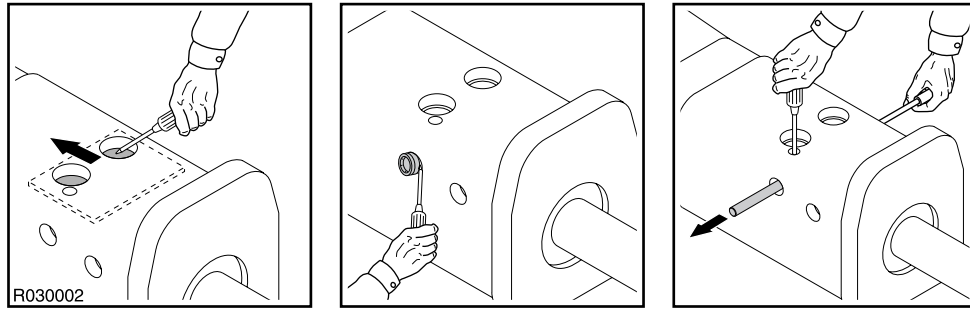

8. Remove tool retaining pins.
9. Remove tool. Use lifting device if necessary. See “Tool specifications” on page 56.

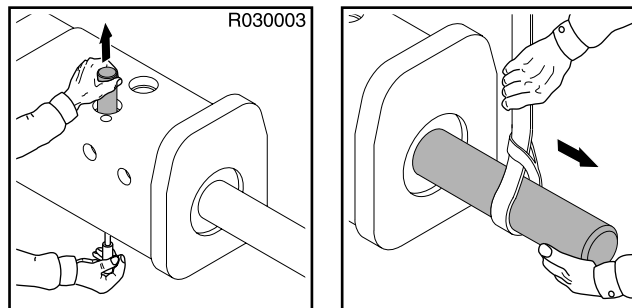

Note: If hammer is still on carrier, it may be easier to stick the tool in the ground and lift the hammer off the tool. Make sure that the tool can not fall.

## INSTALLATION OF TOOL

1. Clean all parts carefully.
2. Measure the tool diameters (X and Y) from the areas marked on the illustration. Replace tool if necessary.
3. Check lower tool bushing for wear. See “Lower tool bushing” on page 46.
4. Check tool seal. Replace if necessary.

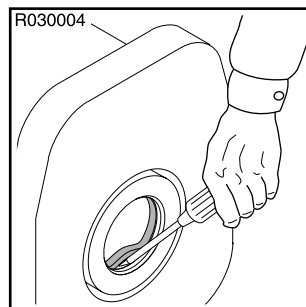

5. Clean and coat tool and retaining pins with grease.

6. Install tool and align the grooves of the tool with the pin bores.
7. Install retaining pins.
8. Install pin.
9. Knock split pin backwards.
10. Check that pin is secured by split pin.
11. Install rubber plugs into their places.
12. Slide the rubber plate back to original position.

### 3. LOWER TOOL BUSHING

#### WEAR LIMITS AND LUBRICANTS FOR LOWER TOOL BUSHING

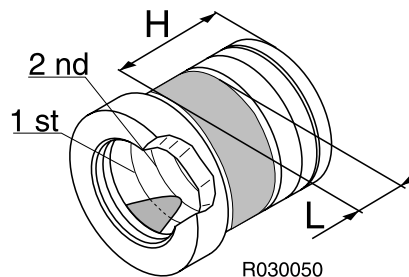

Item	Wear limit
Tool bushing: Inspect the size of the area from where the grease grooves are worn out.	First groove is worn out but the second groove is visible. Bushing can be re-installed. Rotate bushing 90° so that the unused bushing surface will be utilized (bushing has two grooves for retaining pins).
Tool bushing (worn out)	Both first and second grease grooves are worn out. Bushing must be replaced.

Item	Specification
Distance from upper end of bushing (H)	150 mm (5.91 in)
Width of silicone compound (L)	30 mm (1.18 in)

Item	Lubricant
Contact surfaces of front head	Thread grease
Contact surfaces of lower tool bushing	Silicone compound

#### REMOVAL OF LOWER TOOL BUSHING

1. Remove tool.
2. Remove split pin and retaining pin.

3. Remove lower tool bushing.

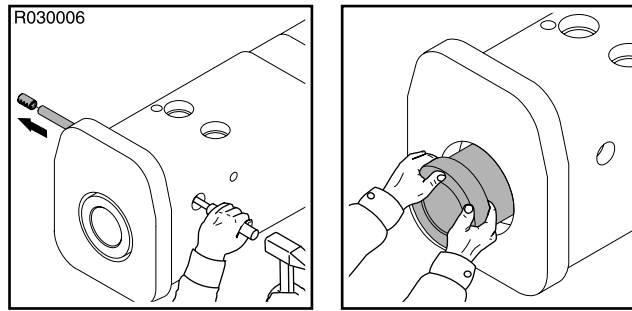

### INSTALLATION OF LOWER TOOL BUSHING

1. Clean all parts carefully.
2. Measure the length of the area (marked Y) from where the grease grooves are worn out. Rotate or replace bushing if necessary.
3. Install seal.
4. Spread silicone compound to the lower tool bushing as specified.

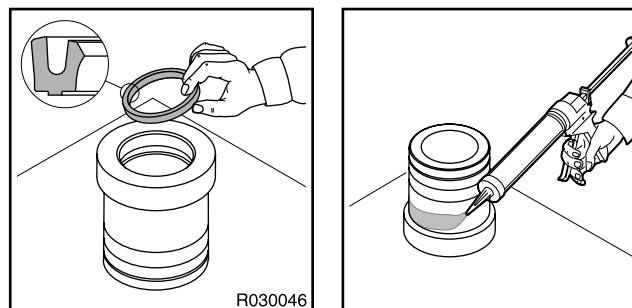

5. Check the condition of the seal in housing. Replace if necessary.

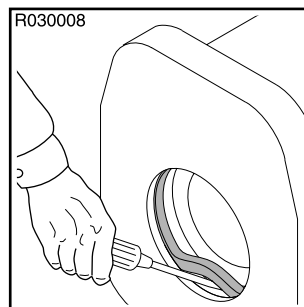

6. Lubricate the contact surfaces of the front head. Leave 50 mm area from the opening of the hole clean from lubricant. Do not allow the silicone compound and the thread grease get mixed.
7. Install the lower tool bushing. Align the groove in the lower tool bushing with the hole in the front head.

## **LOWER TOOL BUSHING**

---

8. Install retaining pin.
9. Install split pin.
10. Install the tool.



---

## 4. TROUBLESHOOTING

---

### 4.1 THE HAMMER DOES NOT START

---

#### **PRESSURE OR RETURN LINES CLOSED**

Check the operation of quick couplings in hammer line. Open hammer line ball valves if closed.

#### **PRESSURE AND RETURN HOSES INSTALLED BACKWARDS**

Swap the pressure and return hoses.

#### **PISTON IS IN ITS LOWER HYDRAULIC BRAKE**

Keep the hammer control valve open and force the tool against an object. The tool head will push the piston out of its brake area. See “Daily operation” on page 20.

#### **GREASE BETWEEN PISTON AND TOOL CONTACT AREA**

Remove the tool and wipe excessive grease off. See “Manual greasing” on page 32.

#### **HAMMER CONTROL VALVE DOES NOT OPEN**

When operating the hammer control valve, check that the pressure line pulsates (this indicates the hammer control valve is opening). If the valve does not operate, check the operating means: mechanical connections, pilot pressure or electrical control.

#### **RELIEF VALVE IN HYDRAULIC CIRCUIT OPENS AT A LOW PRESSURE. HAMMER OPERATING PRESSURE IS NOT REACHED**

Check the installation. Check the relief valve operation. Adjust the relief valve in hydraulic circuit. Measure the high pressure in the hammer inlet line.

#### **EXCESSIVE BACK PRESSURE IN RETURN LINE**

Check the installation. Check the size of the return line.

#### **LEAKAGE FROM PRESSURE TO RETURN IN EXCAVATOR HYDRAULIC CIRCUIT**

Check the installation. Check the pump and the other hydraulic components.

#### **FAILURE IN HAMMER VALVE OPERATION**

The hammer must be serviced in an authorized Rammer service shop.

#### **PISTON FAILURE**

The hammer must be serviced in an authorized Rammer service shop.

### 4.2 THE HAMMER OPERATES IRREGULARLY BUT THE BLOW HAS FULL POWER

---

#### **NOT ENOUGH FEED FORCE FROM EXCAVATOR**

Refer to the correct working methods. See “Daily operation” on page 20.

### **RELIEF VALVE IN HYDRAULIC CIRCUIT OPENS AT A LOW PRESSURE. HAMMER OPERATING PRESSURE IS NOT REACHED**

Check the installation. Check the relief valve operation. Adjust the relief valve in hydraulic circuit. Measure the high pressure in the hammer inlet line.

### **FAILURE IN HAMMER VALVE OPERATION**

The hammer must be serviced in an authorized Rammer service shop.

## **4.3 THE HAMMER OPERATES IRREGULARLY AND BLOW HAS NO POWER**

---

### **THE WORKING METHOD IS NOT CORRECT**

Refer to the correct working methods. See “Daily operation” on page 20.

### **RELIEF VALVE IN HYDRAULIC CIRCUIT OPENS AT A LOW PRESSURE. HAMMER OPERATING PRESSURE IS NOT REACHED**

Check the installation. Check the relief valve operation. Adjust the relief valve in hydraulic circuit. Measure the high pressure in the hammer inlet line. Contact your local dealer for more information.

### **PRESSURE CONTROL VALVE SETTING IS INCORRECT**

The hammer must be serviced in an authorized Rammer service shop.

### **PRESSURE LOSS IN PRESSURE ACCUMULATOR**

The hammer must be serviced in an authorized Rammer service shop.

### **FAILURE IN HAMMER VALVE OPERATION**

The hammer must be serviced in an authorized Rammer service shop.

## **4.4 IMPACT RATE SLOWS DOWN**

---

### **OIL HAS OVERHEATED (OVER +80 °C/+176 °F)**

Check for a fault in the oil cooling system or an internal leak in the hammer. Check the hydraulic circuit of the carrier. Check the relief valve operation in the carrier. Check the line size. Assemble an extra oil cooler.

### **HYDRAULIC OIL VISCOSITY TOO LOW**

Check hydraulic oil. See “Requirements for hydraulic oil” on page 34.

### **EXCESSIVE BACK PRESSURE IN RETURN LINE**

Check the installation. Check the size of the return line.

### **RELIEF VALVE IN HYDRAULIC CIRCUIT OPENS AT A LOW PRESSURE. HAMMER OPERATING PRESSURE IS NOT REACHED**

Check the installation. Check the relief valve operation. Adjust the relief valve in hydraulic circuit. Measure the high pressure in the hammer inlet line. Contact your local dealer for more information.

**LEAKAGE FROM PRESSURE TO RETURN IN EXCAVATOR HYDRAULIC CIRCUIT**

Check the installation. Check the pump and the other hydraulic components.

**PRESSURE LOSS IN PRESSURE ACCUMULATOR**

The hammer must be serviced in an authorized Rammer service shop.

**FAILURE IN HAMMER VALVE OPERATION**

The hammer must be serviced in an authorized Rammer service shop.

---

**4.5 OIL OVERHEATS**

---

**APPLICATION NOT CORRECT FOR HAMMER**

Refer to recommended use and to correct working methods. See “Daily operation” on page 20.

**COOLING CAPACITY OF THE FACTORY OIL COOLER IS TOO SMALL**

Assemble an extra oil cooler.

**RELIEF VALVE IN HYDRAULIC CIRCUIT OPENS AT A LOW PRESSURE. HAMMER OPERATING PRESSURE IS NOT REACHED**

Check the installation. Check the relief valve operation. Adjust the relief valve in hydraulic circuit. Measure the high pressure in the hammer inlet line. Contact your local dealer for more information.

**HYDRAULIC OIL VISCOSITY TOO LOW**

Check hydraulic oil. See “Requirements for hydraulic oil” on page 34.

**LEAKAGE FROM PRESSURE TO RETURN IN EXCAVATOR HYDRAULIC CIRCUIT**

Check the installation. Check the pump and the other hydraulic components.

**INTERNAL OIL LEAK IN THE HAMMER**

The hammer must be serviced in an authorized Rammer service shop.



---

---

# **SPECIFICATIONS**

---

# 1. HAMMER SPECIFICATIONS

## 1.1 TECHNICAL SPECIFICATIONS

Item	Specification
Working weight <sup>a</sup>	1330 kg (2900 lb)
Impact rate <sup>b</sup>	450-800 bpm
Operating pressure <sup>c</sup>	135-145 bar (1960-2100 psi)
Pressure relief, min <sup>d</sup>	200 bar (2900 psi)
Pressure relief, max	220 bar (3190 psi)
Oil flow range	120-170 l/min (32-45 gal/min)
Back pressure, max	10 bar (145 psi)
Input power	41 kW (55 hp)
Tool diameter	125 mm (4.92 in)
Pressure line connection (IN)	SAE 6000 psi 1 1/4"
Return line connection (OUT)	SAE 6000 psi 1 1/4"
Grease connection (G) <sup>e</sup>	BSP-internal 3/8"
Air connection (A) <sup>f</sup>	BSP-internal 3/8"
Pressure line size (minimum inner diameter)	26 mm (1 in)
Return line size (minimum inner diameter)	26 mm (1 in)
Optimum oil temperature	+40 - +60 °C (+104 - +140 °F)
Allowed oil temperature range	-20 - +80 °C (-4 - +176 °F)
Optimum oil viscosity at operating temperature	30-60 cSt
Allowed oil viscosity range	20-1000 cSt
Carrier weight <sup>g</sup>	18-26 ton (40000-57000 lb)
Noise level	85 dB(A)/26-38 m (85-125 ft)
Noise level CITY	85 dB(A)/16-22 m (53-70 ft)

- a. Includes average mounting bracket and standard tool
- b. Actual impact frequency depends on oil flow, oil viscosity, temperature, and material to be broken
- c. Actual pressure depends on oil flow, oil viscosity, temperature, material to be broken and back pressure
- d. Minimum setting = actual operating pressure + 50 bar (730 psi)
- e. Located on the same side of the valve body as the pressure line (IN) connection
- f. Located on the same side of the valve body as the pressure line (IN) connection
- g. Check carrier's lifting capacity from carrier manufacturer

1.2 MAIN DIMENSIONS E 65, E 65 CITY

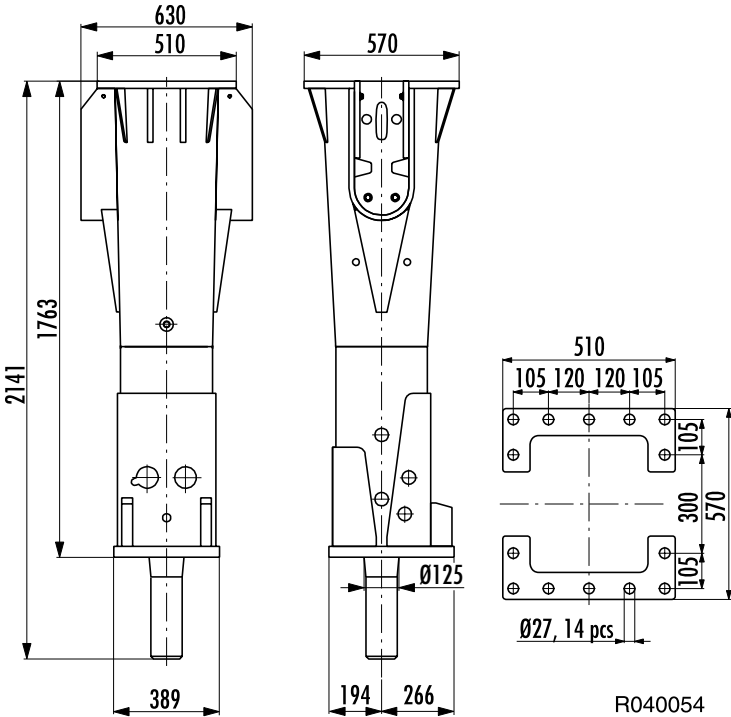

## 2. TOOL SPECIFICATIONS

### 2.1 TOOL SPECIFICATIONS E 65

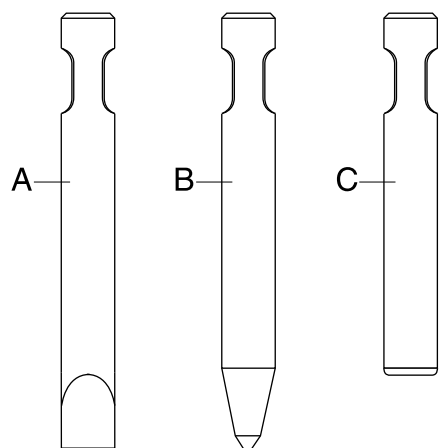

R040032

Tool	Part no.	Length	Weight	Diameter
Chisel (A)	651	1050 mm (41.3 in)	85 kg (187 lb)	125 mm (4.92 in)
Moil point (B)	653	1050 mm (41.3 in)	84 kg (185 lb)	125 mm (4.92 in)
Blunt (C)	654	850 mm (33.5 in)	74 kg (163 lb)	125 mm (4.92 in)

There is a wider selection of tools available for different applications. Consult with your local dealer for more information.





Sandvik Tamrock Corp., Breakers Lahti  
Taivalkatu 8, P.O. Box 165, FIN-15101 Lahti, Finland  
Phone Int. +358 205 44 161, Telefax Int. +358 205 44 160  
[www.rammer.com](http://www.rammer.com)