

PARTS MANUAL

PME64ENG.603

HYDRAULIC HAMMER
RAMMER E 64
RAMMER E 64 CITY
RAMMER E 64 CITY-JET

Serial No.

64AAB0364-UP

64ADB0364-UP

64AEB0364-UP

TABLE OF CONTENTS

1. Housing unit E 64	4
2. Housing unit E 64 CITY	6
3. Housing unit E 64 CITY-JET	8
4. Accumulator E 64	10
5. Main valve E 64	11
6. Check valve E 64	12
7. Pressure control valve E 64	14
8. Tie rods E 64	15
9. Body parts E 64	16
10. Front head E 64	18
11. Lower tool bushing E 64	19
12. Seal set E 64	20

GENUINE RAMMER SPARE PARTS

Rammer genuine spare parts are designed and manufactured by using the latest technological knowledge and engineering skills. Rammer spare parts are made of the best available materials with the most advanced manufacturing techniques.

It is important that you use only genuine Rammer spare parts, to ensure easy operation, maintenance and repair of the product. Please note that eventual warranty claims will be handled only if you have used genuine Rammer parts in your Rammer.

LOCATION OF THE SERIAL NUMBER

It's important to make correct reference to the serial number of the product when ordering spare parts. Identification of serial number is the only proper means of maintaining and identifying parts for a specific product. The location of equipment serial number is pointed in "Operation and maintenance" manual.

SPARE PART ORDERS

Quick spare part deliveries are secured by exact orders.

Required information:

- Name of customer and contact person
 - Order number (when available)
 - Delivery address
 - Mode of delivery (air mail etc.)
 - Required delivery date
 - Invoicing address
 - Model and serial number of the product
 - Name, number and required amount of spare parts
-

PARTS

1. HOUSING UNIT E 64

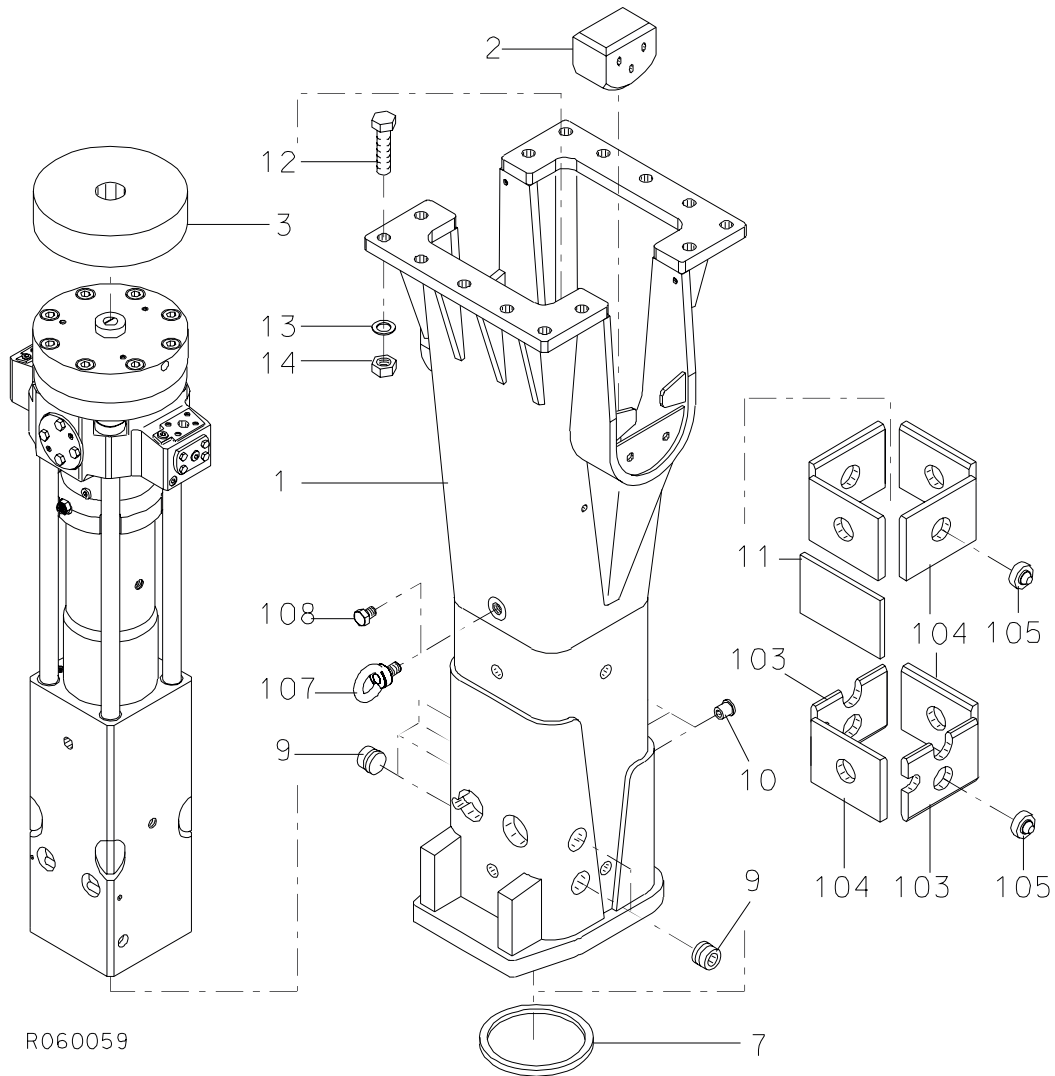

Item	Description	Part no.	Specification	Note	Qty
1	Housing (incl. parts 103-108)	103930			1
2	Pad	300768			2
3	Buffer	300767			1
7	Seal	102142			1
9	Rubber plug	400676	D50		6
10	Rubber plug	400566	D25		3
11	Shield plate	102559			1
12	Hex. screw	90589	M24x110-12.9 DIN 931		14
13	Washer	90511	25 DIN 6916		14
14	Lock nut	90507	M24-12 DIN 985		14
103	Wear plate	102621			2
104	Wear plate	102729			6
105	Pin	101133			8
107	Lifting eye	90605	M24 DIN 580		1
108	Hex. screw	900025	M24x35-8.8 DIN 933		1
Kit	Label set	104159			1

2. HOUSING UNIT E 64 CITY

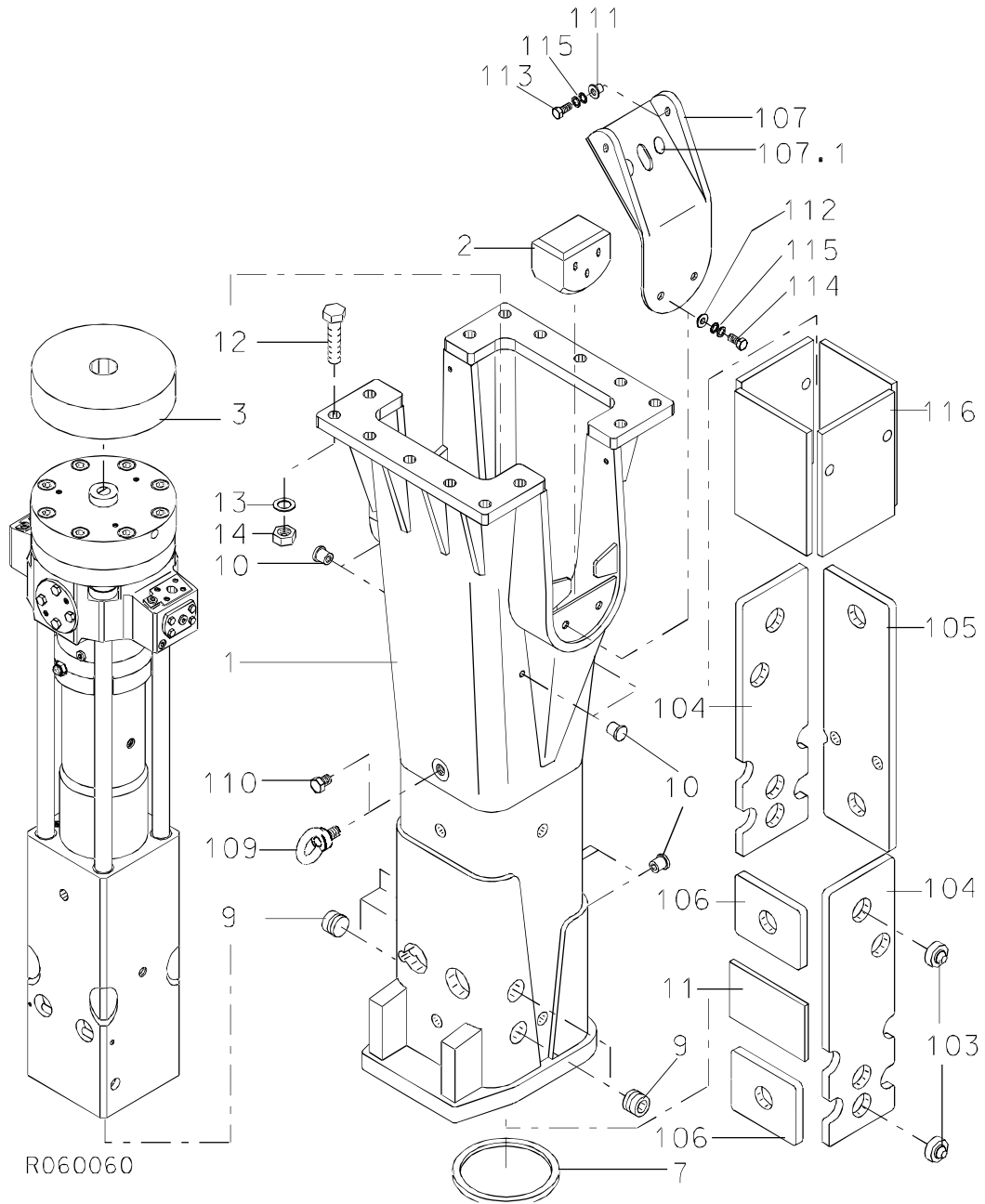

Item	Description	Part no.	Specification	Note	Qty
1	Housing (incl. parts 103-116)	102804			1
2	Pad	300768			2
3	Buffer	300767			1
7	Seal	102142			1
9	Rubber plug	400676	D50		6
10	Rubber plug	400566	D25		7
11	Shield plate	102559			1
12	Hex. screw	90589	M24x110-12.9 DIN 931		14
13	Washer	90511	25 DIN 6916		14
14	Lock nut	90507	M24-12 DIN 985		14
103	Pin	101133			8
104	Wear plate	103977			2
105	Wear plate	103976			1
106	Wear plate	103978			2
107	Shield plate (incl. part 107.1)	103008			2
107.1	Shield plug	103875			2
109	Lifting eye	90605	M24 DIN 580		1
110	Hex. screw	900025	M24x35-8.8 DIN 933		1
111	Middle bushing	102944			4
112	Middle bushing	102939			4
113	Hex. screw	91050	M12x40-8.8 DIN 933		4
114	Hex. screw	90513	M12x30-8.8 DIN 933		4
115	Lock washer	91012	M12 NORD-LOCK		8
116	Damper plate	102558			4
Kit	Label set	104160			1

3. HOUSING UNIT E 64 CITY-JET

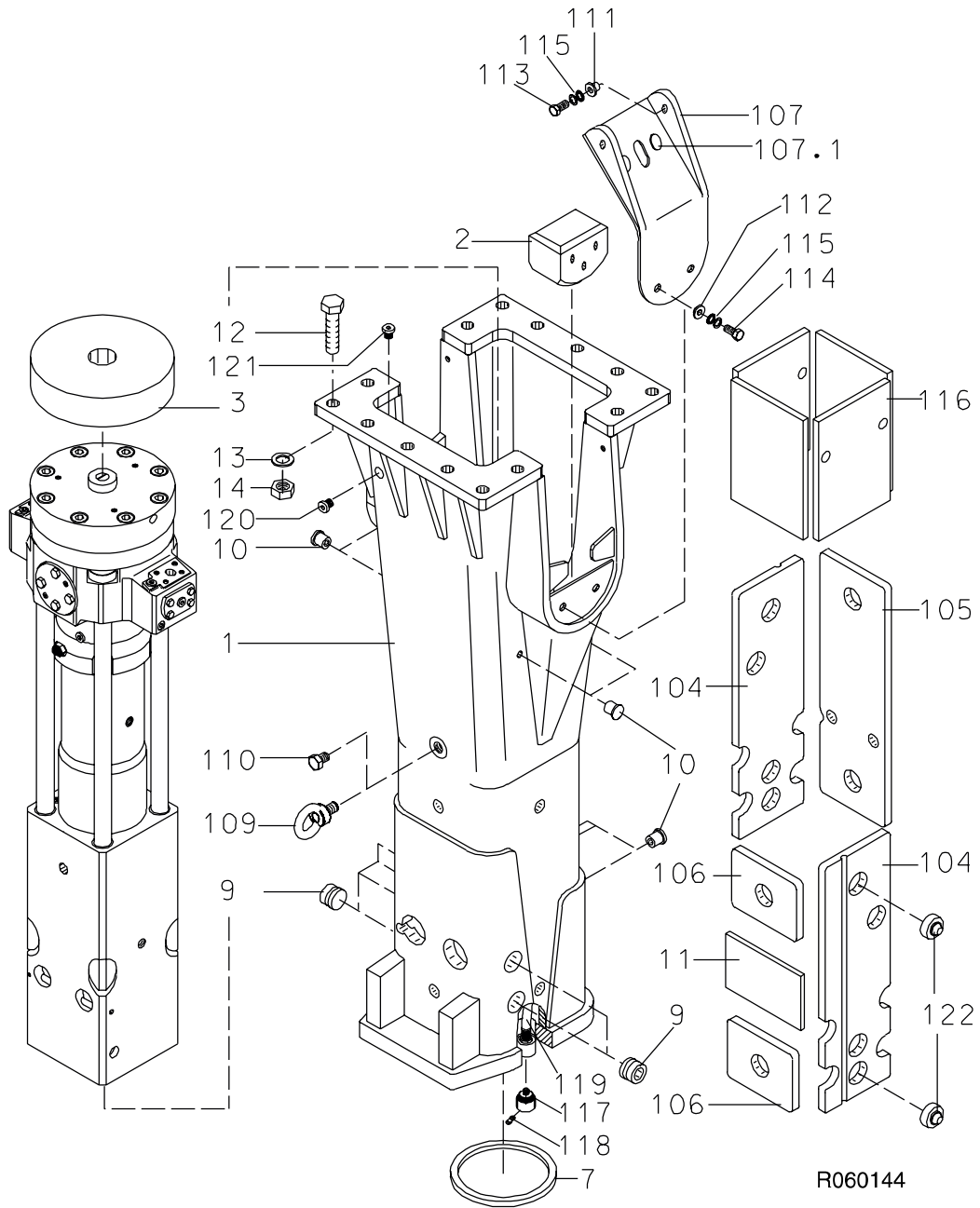

Item	Description	Part no.	Specification	Note	Qty
1	Housing (incl. parts 104-122)	104399			1
2	Pad	300768			2
3	Buffer	300767			1
7	Seal	102142			1
9	Rubber plug	400676	D50		6
10	Rubber plug	400566	D25		7
11	Shield plate	102559			1
12	Hex. screw	90589	M24x110-12.9 DIN 931		14
13	Washer	90511	25 DIN 6916		14
14	Lock nut	90507	M24-12 DIN 985		14
104	Wear plate	104385			2
105	Wear plate	103976			1
106	Wear plate	103978			2
107	Shield plate (incl. part 107.1)	103008			2
107.1	Shield plug	103875			2
109	Lifting eye	90605	M24 DIN 580		1
110	Hex. screw	900025	M24x35-8.8 DIN 933		1
111	Middle bushing	102944			4
112	Middle bushing	102939			4
113	Hex. screw	91050	M12x40-8.8 DIN 933		4
114	Hex. screw	90513	M12x30-8.8 DIN 933		4
115	Lock washer	91012	M12 NORD-LOCK		8
116	Damper plate	102558			4
117	Guide	103047			2
118	Nozzle	102783	SSCO B1/8-GG-SS5		2
119	Hose assembly	104407			1
120	Flange plug	90424	R1/2		1
121	Flange plug	90403	R1/4		1
122	Pin	101133			8
Kit	Label set	106136			1

4. ACCUMULATOR E 64

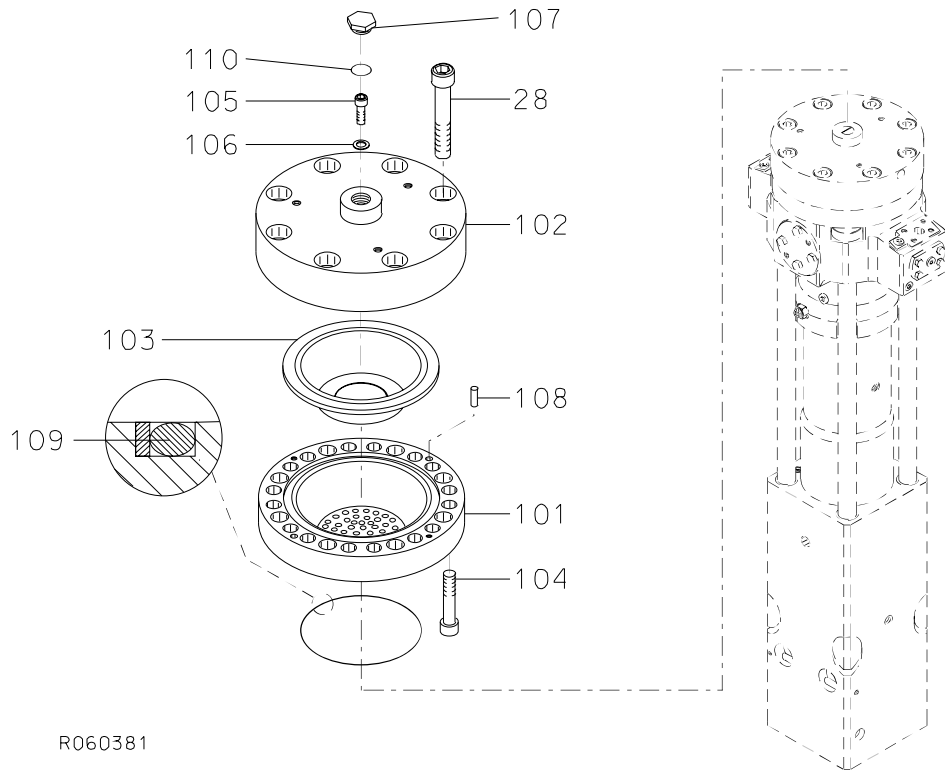

R060381

Item	Description	Part no.	Specification	Note	Qty
1	Accumulator (incl. parts 101-110)	300791			1
101	Accumulator bottom	100511			1
102	Accumulator cover	100510			1
103	Membrane	30190			1
104	Accumulator screw	40392			16
105	Filling plug	40368			1
106	Usit-ring	90056	U8.7-14-1	*	1
107	Shield plug	154015			1
108	Parallel pin	90342	10m6x30 DIN 6325		2
109	Seal	40104	D114	*	1
110	O-ring	910006	D23	*	1
28	Accumulator screw	301020			8
	*) Are included in seal set				

5. MAIN VALVE E 64

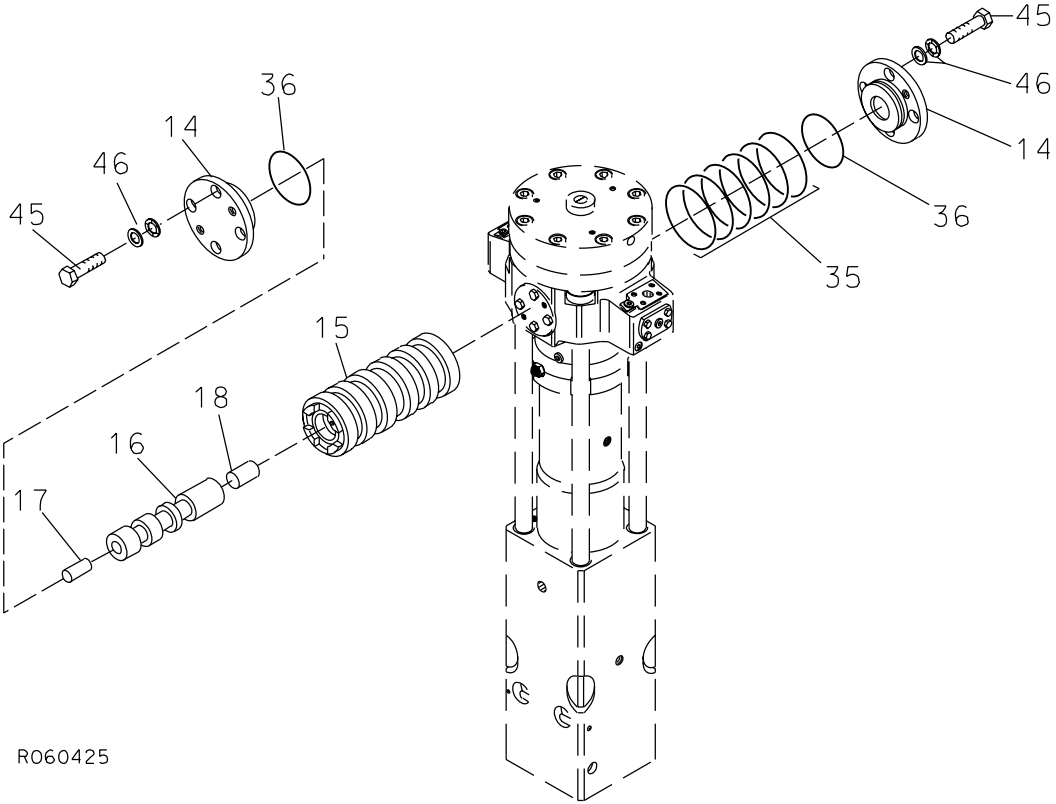

R060425

Item	Description	Part no.	Specification	Note	Qty
14	Cover	40418			2
15	Main valve bushing	30217			1
16	Main spool	300803			1
17	Spool	40419			1
18	Spool	40112			1
35	O-ring	90024	D90	*	6
36	O-ring	90025	D85	*	2
45	Hex. screw	90514	M16x30-8.8 DIN 933		8
46	Lock washer	90597	M16 NORD-LOCK		8
	*) Are included in seal set				

6. CHECK VALVE E 64

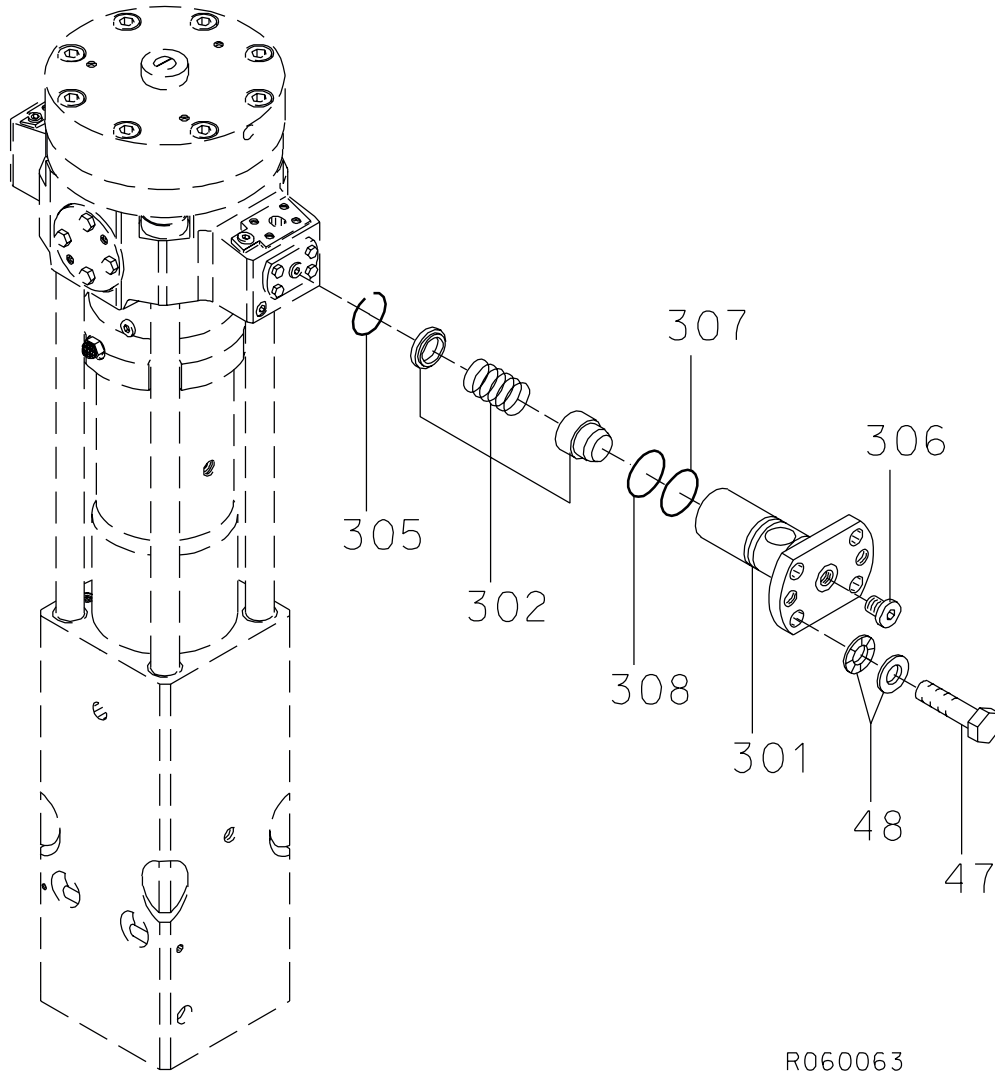

R060063

Item	Description	Part no.	Specification	Note	Qty
3	Check valve (incl. parts 301-308, 47 and 48)	300801			1
301	Check valve housing	300800			1
302	Check valve	90532			1
305	Spring ring	90302	B30 DIN 7993		1
306	Flange plug	90403	R1/4		1
307	O-ring	90017	D34		1
308	O-ring	90004	D32		1
47	Hex. screw	90513	M12x30-8.8 DIN 933		4
48	Lock washer	91012	M12 NORD-LOCK		4
	*) Are included in seal set				

7. PRESSURE CONTROL VALVE E 64

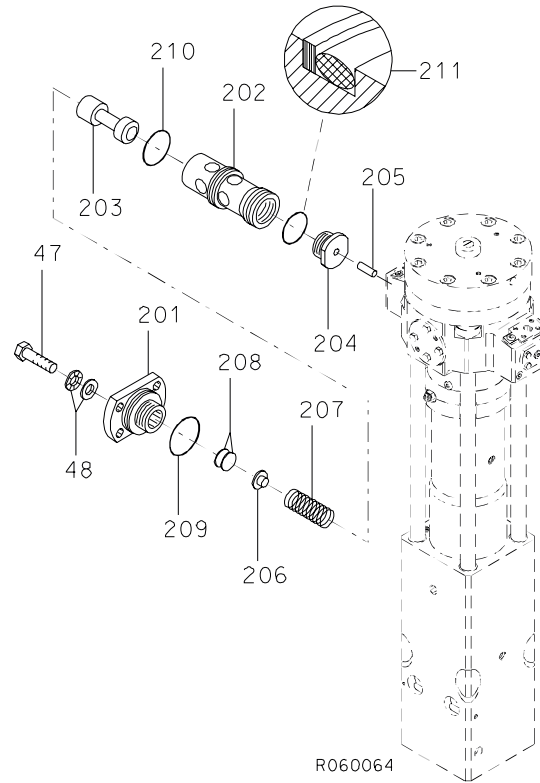

Item	Description	Part no.	Specification	Note	Qty
2	Pressure control valve (incl. parts 201-211, 47 and 48)	300793			1
201	Cover	300792			1
202	Valve housing	32069			1
203	Spool	400652			1
204	Guide	40364			1
205	Spool	40365			1
206	Spring guide	40275			1
207	Spring	90104			1
208	Shim plate	42364	S=1.5		X
208	Shim plate	42365	S=1.25		X
208	Shim plate	42366	S=0.9		X
209	O-ring	90018	D55	*	1
210	O-ring	90019	D49	*	1
211	Seal	40391	D44	*	1
47	Hex. screw	90513	M12x30-8.8 DIN 933		4
48	Lock washer	91012	M12 NORD-LOCK		4
	*) Are included in seal set				

8. TIE RODS E 64

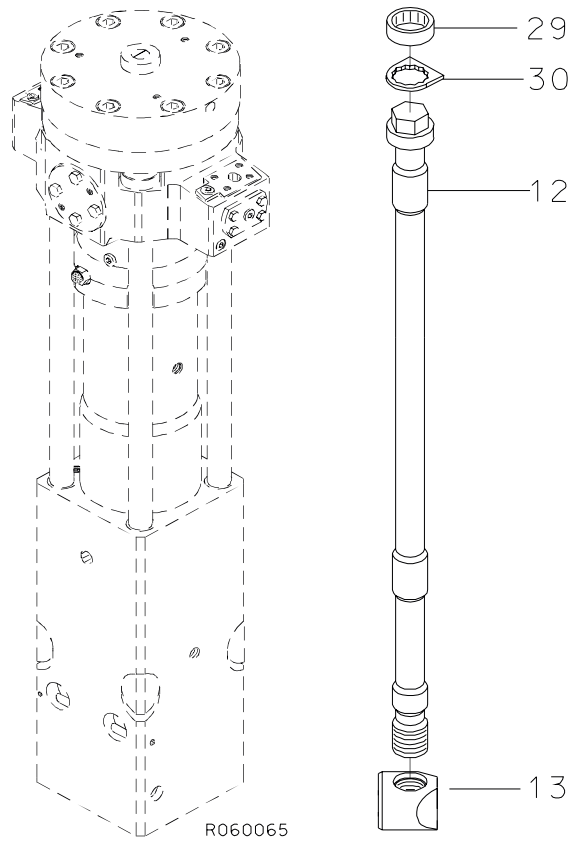

Item	Description	Part no.	Specification	Note	Qty
12	Tie rod	104013			4
13	Tie rod nut	104012			4
29	Rubber ring	40396			4
30	Lock plate	40367			4

9. BODY PARTS E 64

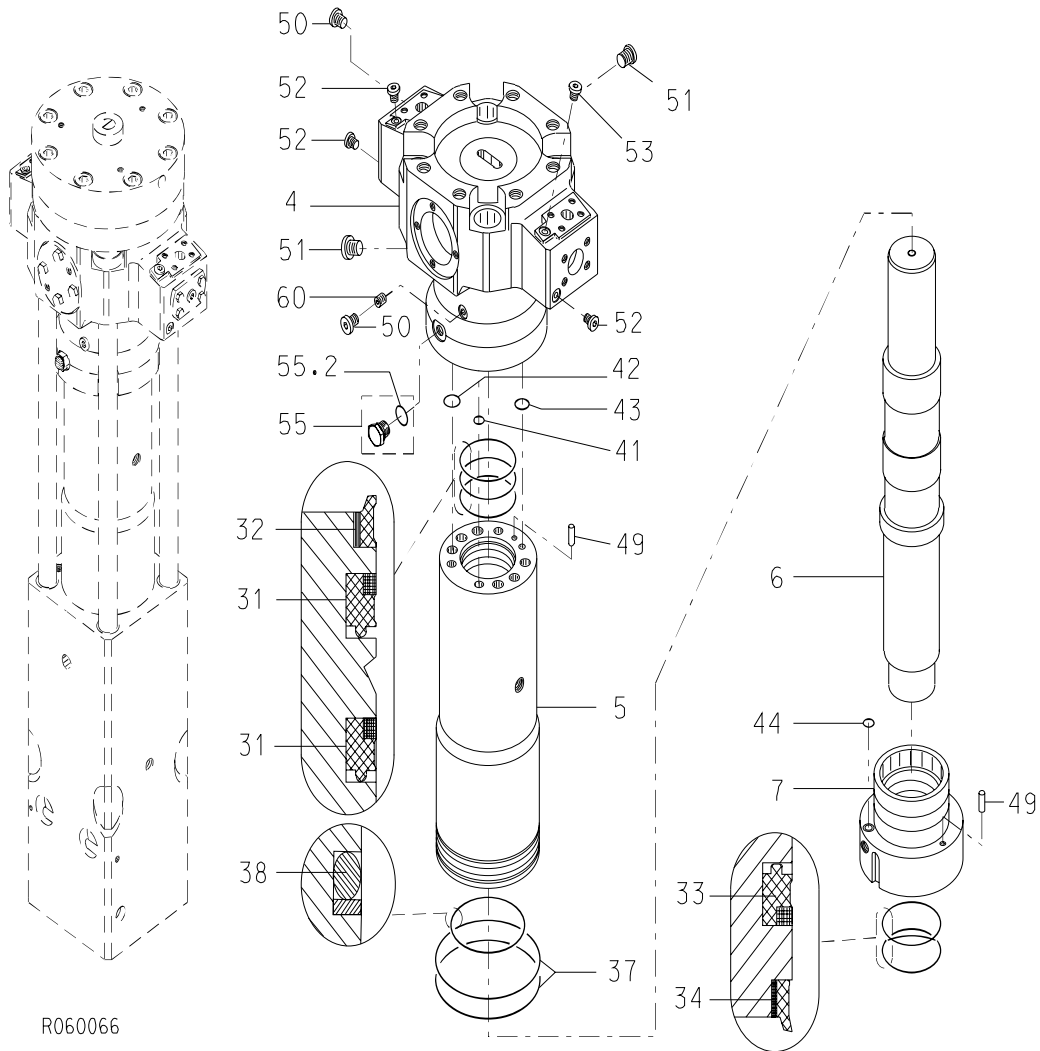

Item	Description	Part no.	Specification	Note	Qty
4	Valve body (incl. parts 50, 51, 52, 53, 55 and 60)	100480			1
5	Cylinder	100505			1
6	Piston	100507			1
7	Seal carrier	100506			1
31	Seal	911037	D85	*	2
32	Wiper	94043	D85	*	1
33	Seal	911039	D100	*	1
34	Wiper	911040	D100	*	1
37	O-ring	90013	D180	*	2
38	Seal	40390	D134	*	1
41	O-ring	90012	D19	*	2
42	Seal	40388	D26	*	6
43	Seal	40139	D24	*	2
44	O-ring	90011	D14	*	2
49	Parallel pin	90342	10m6x30 DIN 6325		2
50	Flange plug	90444	R3/8		2
51	Flange plug	90424	R1/2		4
52	Flange plug	90403	R1/4		3
53	Breather	400592			1
55	Breather (incl. part 55.2)	101200			1
55.2	O-ring	902122	D24	*	1
60	Taper plug	93125	DIN 906-R1/4		1
	*) Are included in seal set				

10. FRONT HEAD E 64

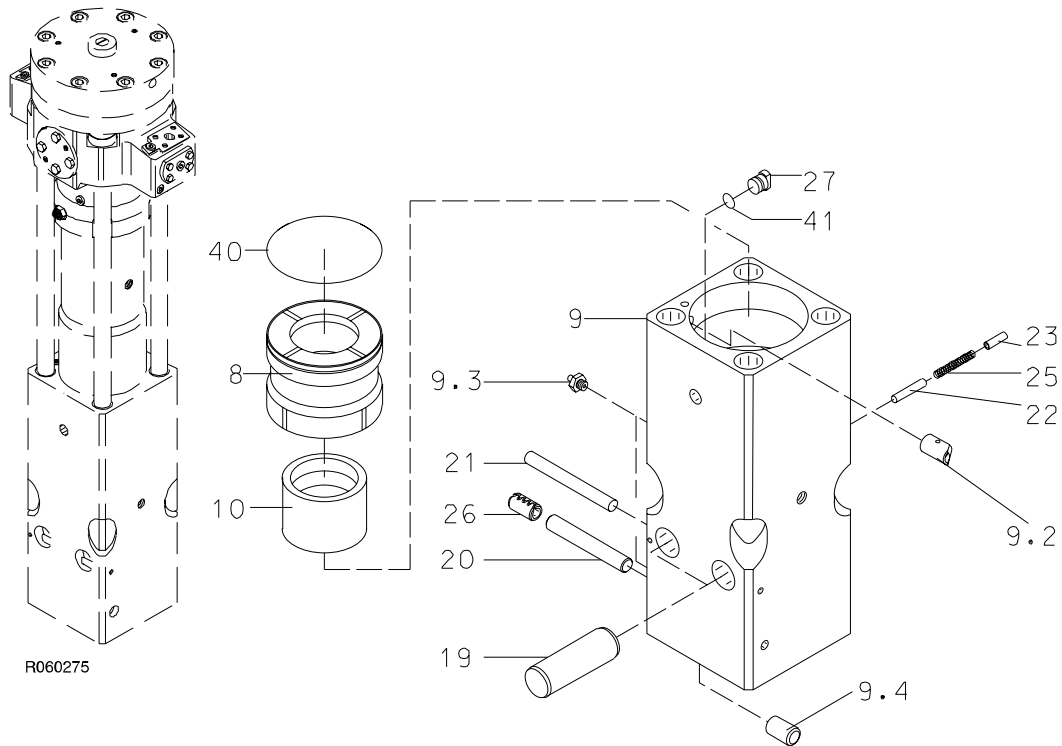

Item	Description	Part no.	Specification	Note	Qty
8	Thrust ring	200460			1
9	Front head (incl. parts 9.2-9.4)	110701			1
9.2	Plug	110705			1
9.3	Grease nipple	90200	R1/4		2
9.4	Plug	110710			1
10	Upper tool bushing	300773			1
19	Tool retaining pin	400584	D50		2
20	Retaining pin	400323	D25		1
21	Retaining pin	400585	D20		1
22	Retaining pin	400588	D12		1
23	Split pin	90321	12x40 DIN 1481		1
25	Spring	42461			1
26	Split pin	901136	D25x50		1
27	Wedge	40353			1
40	O-ring	910016		*	1
41	O-ring	90012	D19	*	1
	*) Are included in seal set				

11. LOWER TOOL BUSHING E 64

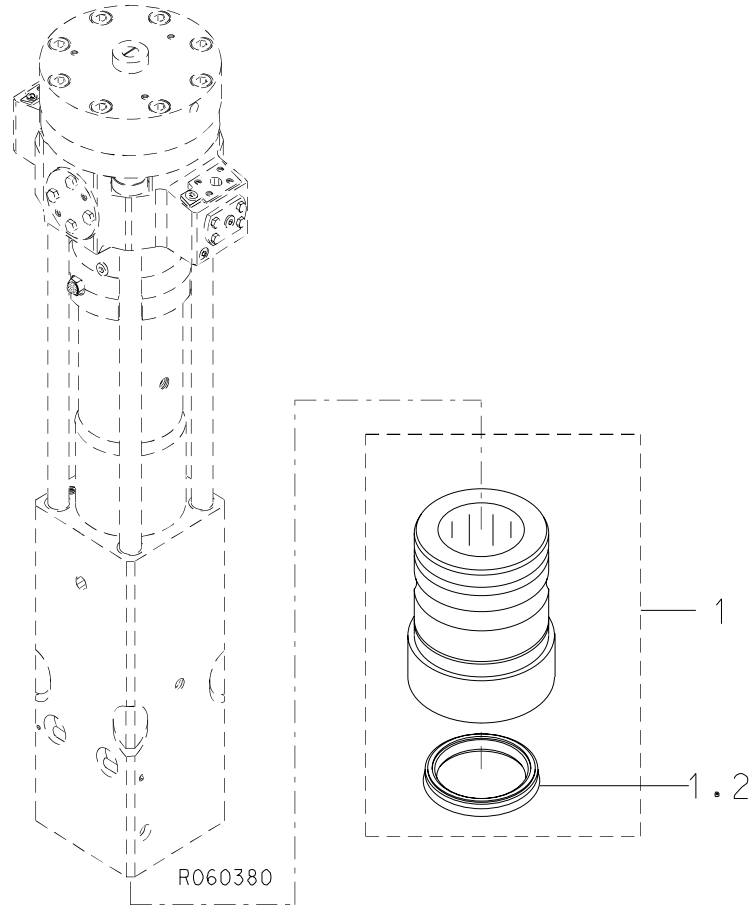

Item	Description	Part no.	Specification	Note	Qty
1	Lower tool bushing (incl. part 1.2)	102154			1
1.2	Seal	102145			1

12. SEAL SET E 64

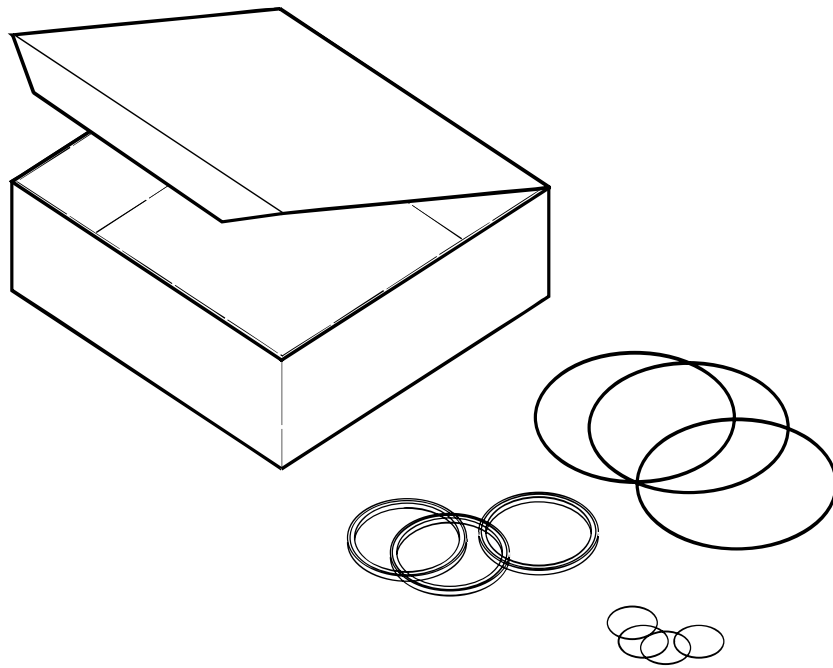

R060012

Item	Description	Part no.	Specification	Note	Qty
Kit	Seal set (incl. parts 1-24)	400679			1
1	Seal	911037	D85		2
2	Wiper	94043	D85		1
3	Seal	911039	D100		1
4	Wiper	911040	D100		1
5	O-ring	90024	D90		6
6	O-ring	90025	D85		2
7	O-ring	90013	D180		2
8	Seal	40390	D134		1
10	O-ring	910016	D174		1
11	O-ring	90012	D19		3
12	Seal	40388	D26		6
13	Seal	40139	D24		2
14	O-ring	90011	D14		2
15	O-ring	902122	D24		1
16	Usit-ring	90056	U8.7-14-1		1
17	Seal	40104	D114		1
18	O-ring	901026	D14		1
19	O-ring	90018	D55		1
20	O-ring	90019	D49		1
21	Seal	40391	D44		1
22	O-ring	90017	D34		1
23	O-ring	90004	D32		1
24	O-ring	910006	D23		1

SANDVIK TAMROCK CORP.
Breakers Lahti
Taivalkatu 8, P.O. Box 165, FIN-15101 Lahti, Finland
Phone Int. +358 205 44 161, Telefax Int. +358 205 44 160,
Internet <http://www.rammer.com>

81-44-14007-39-120-273
81-44-14007-39-136-133