

ENG 8/03

PARTS MANUAL
PMG100TENG.803

HYDRAULIC HAMMER

RAMMER G 100 TUNNEL

Serial No.
10TEB0081-UP

TABLE OF CONTENTS

1. Housing unit G 100 TUNNEL	4
2. Accumulator G 100	6
3. Main valve G 100	7
4. Check valve G 100	8
5. Pressure control valve G 100	9
6. Tie rods G 100 TUNNEL	10
7. Body parts G 100 TUNNEL	12
8. Front head G 100 TUNNEL	14
9. Lower tool bushing G 100 TUNNEL	16
10. Seal set G 100 TUNNEL	17

GENUINE RAMMER SPARE PARTS

Rammer genuine spare parts are designed and manufactured by using the latest technological knowledge and engineering skills. Rammer spare parts are made of the best available materials with the most advanced manufacturing techniques.

It is important that you use only genuine Rammer spare parts, to ensure easy operation, maintenance and repair of the product. Please note that eventual warranty claims will be handled only if you have used genuine Rammer parts in your Rammer.

LOCATION OF THE SERIAL NUMBER

It's important to make correct reference to the serial number of the product when ordering spare parts. Identification of serial number is the only proper means of maintaining and identifying parts for a specific product. The location of equipment serial number is pointed in "Operation and maintenance" manual.

SPARE PART ORDERS

Quick spare part deliveries are secured by exact orders.

Required information:

- Name of customer and contact person
 - Order number (when available)
 - Delivery address
 - Mode of delivery (air mail etc.)
 - Required delivery date
 - Invoicing address
 - Model and serial number of the product
 - Name, number and required amount of spare parts
-

PARTS

1. HOUSING UNIT G 100 TUNNEL

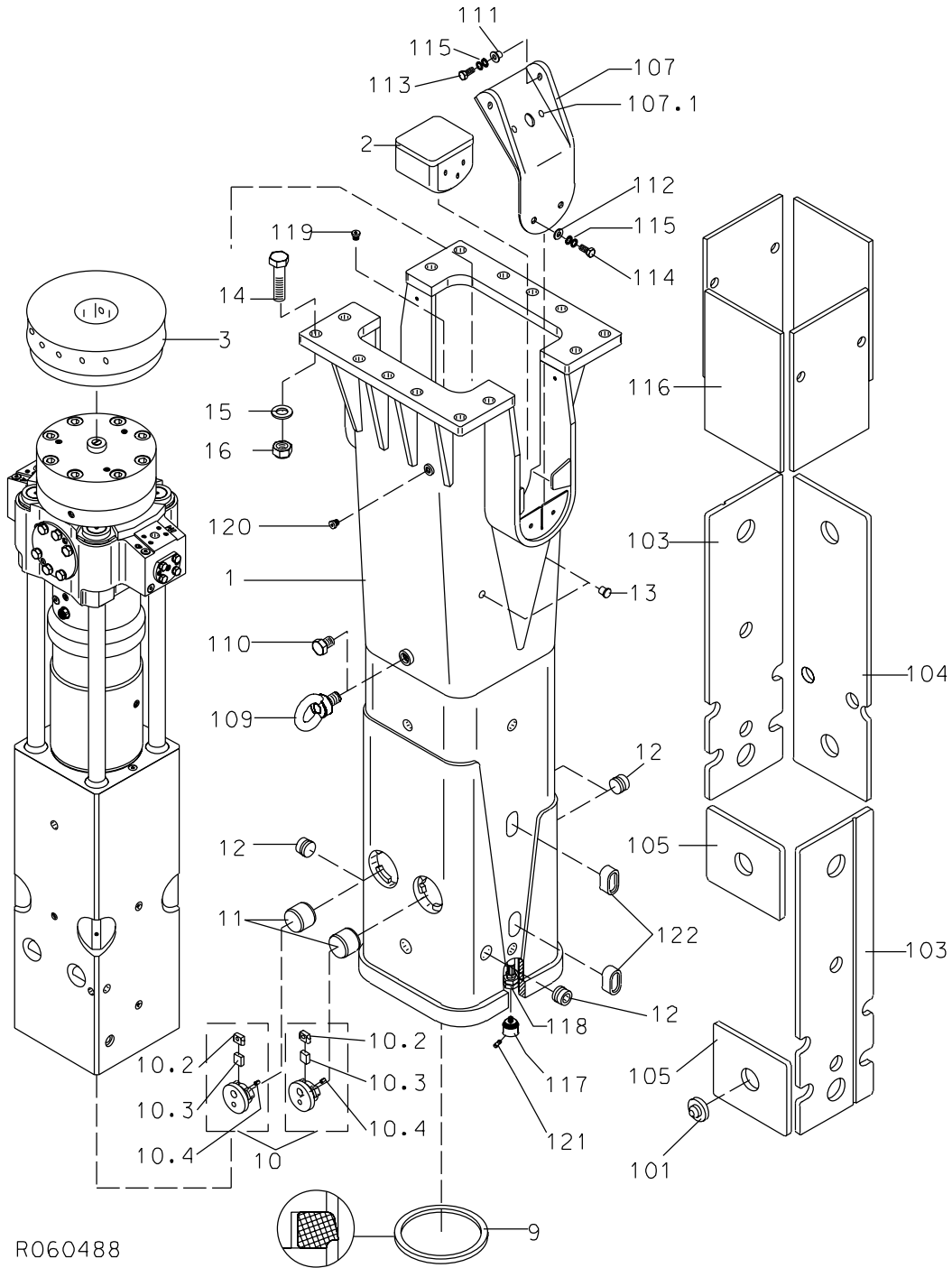

HOUSING UNIT G 100 TUNNEL

Item	Description	Part no.	Specification	Note	Qty
1	Housing (incl. parts 101-122)	104187			1
2	Pad	103409			2
3	Buffer	104137			1
9	Seal	102144			1
10	Cover (incl. parts 10.2-10.4)	106081			2
10.2	Bar	106083			1
10.3	Buffer	106082			1
10.4	Split pin	90327			1
11	Tool retaining pin	103394			2
12	Rubber plug	400676	D50		4
13	Rubber plug	400566	D25		4
14	Hex. screw	90520	M36x140-8.8 DIN 931		14
15	Washer	903003	37 DIN 6916		14
16	Lock nut	90519	M36-8 DIN 985		14
101	Pin	102389			8
103	Wear plate	104126			2
104	Wear plate	104125			1
105	Wear plate	104124			2
107	Shield plate (incl. part 107.1)	102945			2
107.1	Plug	103875			2
109	Lifting eye bolt	901464	M36 DIN 580		1
110	Hex. screw	901465	M36x40-8.8 DIN933		1
111	Middle bushing	102944			4
112	Washer	902815	D13		4
113	Hex. screw	91050	M12x40-8.8 DIN 933		4
114	Hex. screw	91088	M12x20-8.8 DIN 933		4
115	Lock washer	91012	M12 NORD-LOCK		8
116	Damper plate	102564			4
117	Guide	103047			2
118	Hose assembly	104122			1
119	Flange plug	90403	R1/4		1
120	Flange plug	90424	R1/2		1
121	Nozzle	102783	SSCO B1/8-GG-SS5		2
122	Rubber plug	300950			2
Kit	Label set	105085			1

2. ACCUMULATOR G 100

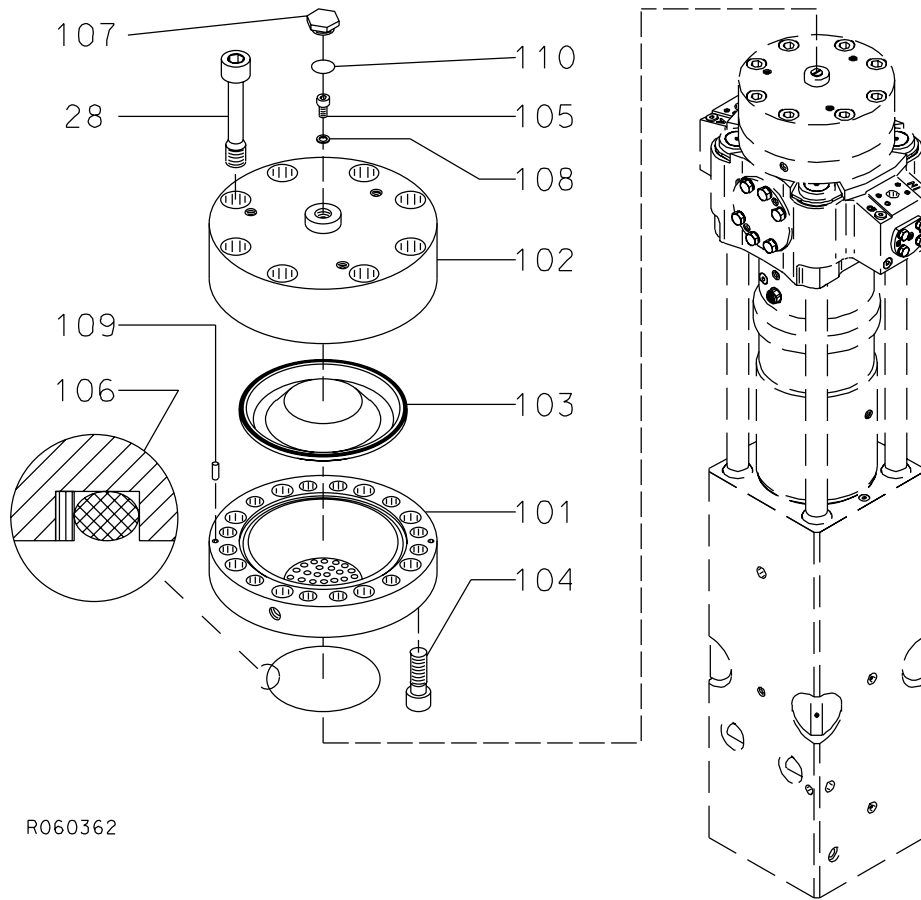

R060362

Item	Description	Part no.	Specification	Note	Qty
1	Accumulator (incl. parts 101-110)	110561			1
101	Accumulator bottom	110560			1
102	Accumulator cover	100491			1
103	Membrane	104022			1
104	Accumulator screw	40528			12
105	Filling plug	40368			1
106	Seal	40536	D144	*	1
107	Shield plug	154015			1
108	Usit-ring	90056	U8.7-14-1	*	1
109	Parallel pin	90304	10m6x24 DIN 6325		2
110	O-ring	910006	D23	*	1
28	Accumulator screw	300711			8
	*) Are included in seal set				

3. MAIN VALVE G 100

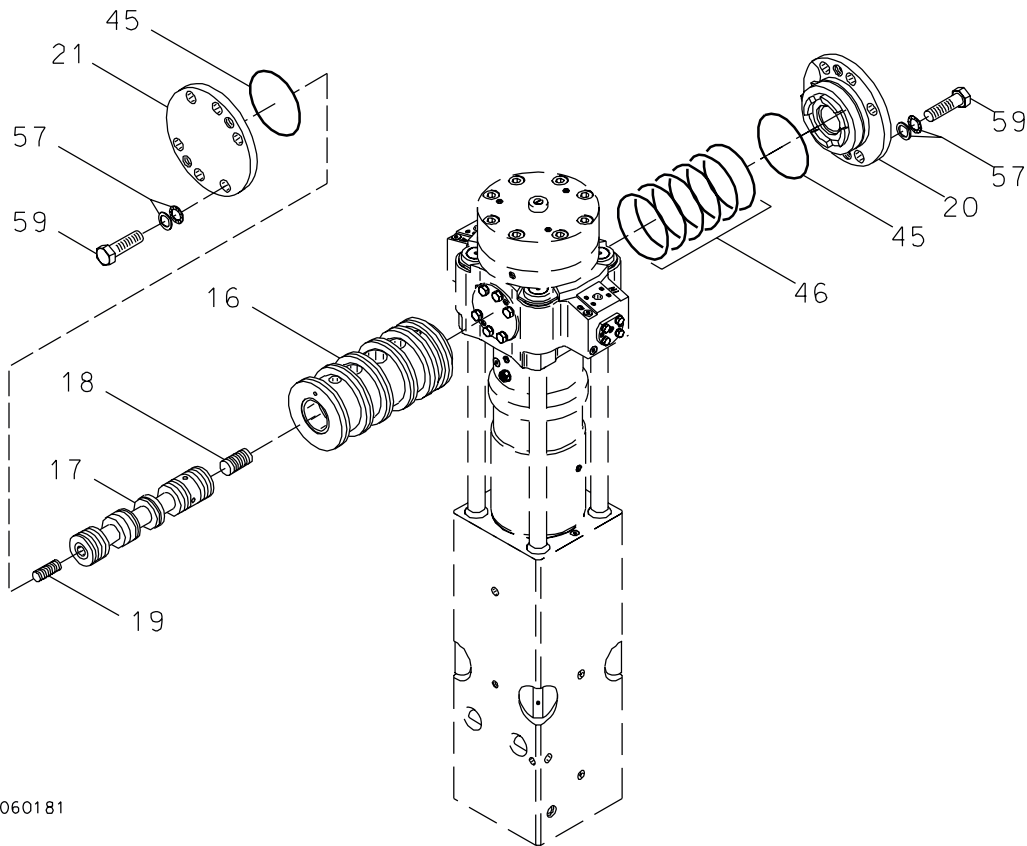

R060181

Item	Description	Part no.	Specification	Note	Qty
16	Main valve bushing	104186			1
17	Main spool	300921			1
18	Spool	400649			1
19	Spool	40523			1
20	Cover	30260			1
21	Cover	30295			1
45	O-ring	90032	D120	*	2
46	Seal	902644		*	6
57	Lock washer	91010	M20 NORD-LOCK		12
59	Hex. screw	900036	M20x70-10.9 DIN 931		12
	*) Are included in seal set				

4. CHECK VALVE G 100

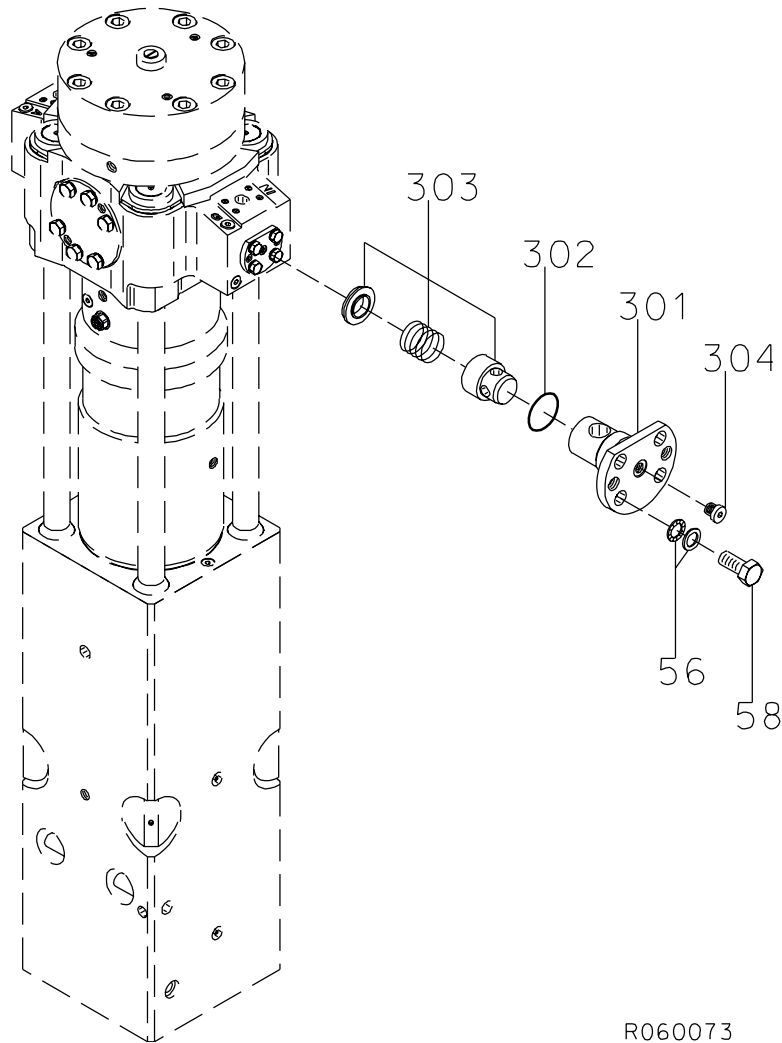

R060073

Item	Description	Part no.	Specification	Note	Qty
3	Check valve (incl. parts 301-304)	300725			1
301	Cover	300696			1
302	O-ring	90007	D44	*	1
303	Check valve	915077			1
304	Flange plug	90403	R1/4		1
56	Lock washer	90597	M16 NORD-LOCK		4
58	Hex. screw	90517	M16x35-8.8 DIN 933		4
	*) Are included in seal set				

5. PRESSURE CONTROL VALVE G 100

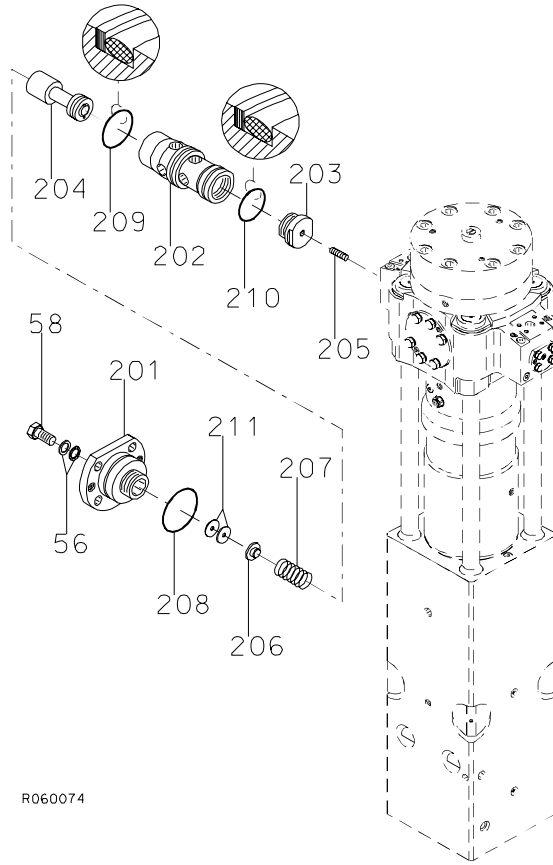

R060074

Item	Description	Part no.	Specification	Note	Qty
2	Pressure control valve (incl. parts 201-211)	300723			1
201	Cover	300871			1
202	Valve housing	300814			1
203	Guide	400581			1
204	Spool	300866			1
205	Spool	400582			1
206	Spring guide	42174			1
207	Spring	90118			1
208	O-ring	90030	D75	*	1
209	Seal	40533	D65	*	1
210	Seal	41374	D55	*	1
211	Shim plate	42363	S=0.9		X
211	Shim plate	42362	S=1.25		X
211	Shim plate	42361	S=1.5		X
56	Lock washer	90597	M16 NORD-LOCK		4
58	Hex. screw	90517	M16x35-8.8 DIN 933		4
	*) Are included in seal set				

6. TIE RODS G 100 TUNNEL

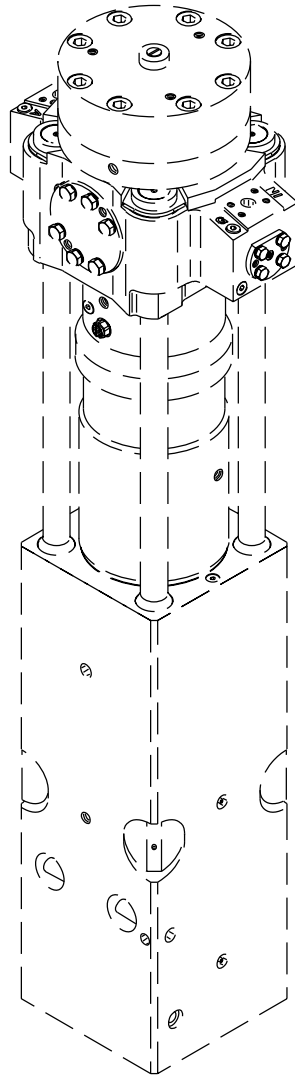

R060399

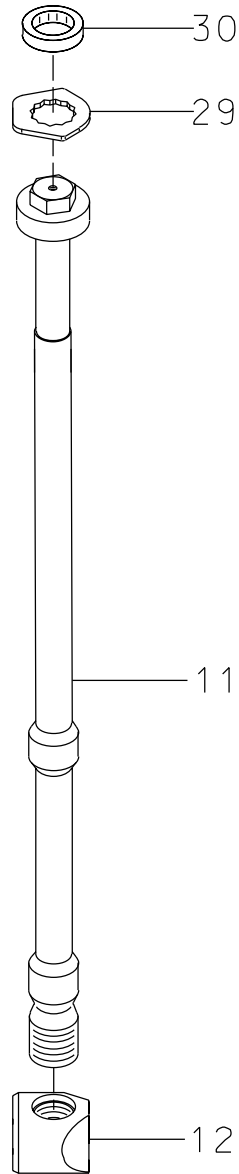

TIE RODS G 100 TUNNEL

Item	Description	Part no.	Specification	Note	Qty
11	Tie rod	103777			4
12	Tie rod nut	112491			4
29	Lock plate	400478			4
30	Rubber ring	40586			4

7. BODY PARTS G 100 TUNNEL

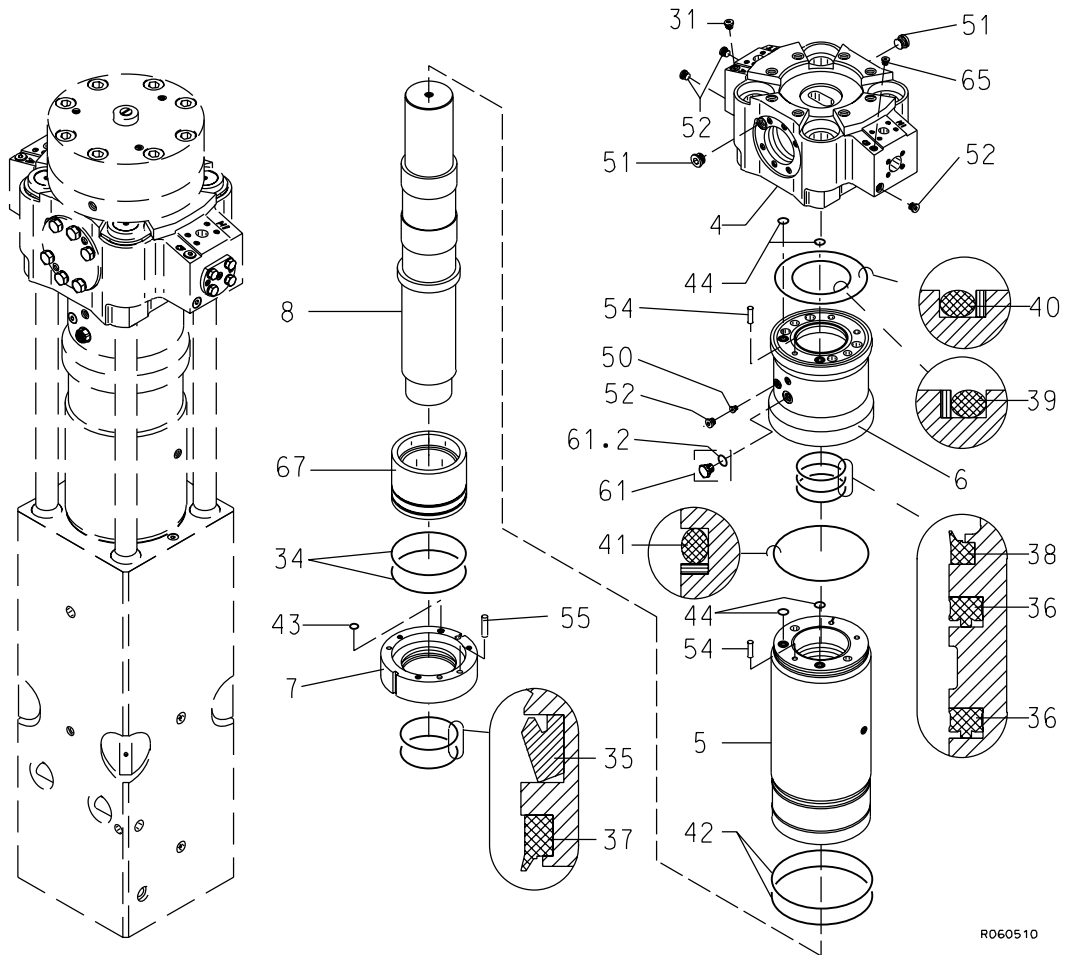

R060510

BODY PARTS G 100 TUNNEL

Item	Description	Part no.	Specification	Note	Qty
4	Valve body	100394			1
5	Cylinder	102999			1
6	Seal carrier	100415			1
7	Seal carrier	103000			1
8	Piston	100417			1
31	Breather	400562			1
34	O-ring	90036	D209	*	2
35	Seal	903066	D160	*	1
36	Seal	911023	D142	*	2
37	Wiper	90065	D160	*	1
38	Wiper	90064	D142	*	1
39	Seal	400474	D160	*	1
40	Seal	400476	D260	*	1
41	Seal	400481	D280	*	1
42	O-ring	910015	D269	*	2
43	O-ring	90011	D14	*	1
44	O-ring	910018	D21	*	4
50	Flange plug	90403	R1/4		1
51	Flange plug	90410	R1		2
52	Flange plug	90424	R1/2		4
54	Parallel pin	90317	16m6x50 DIN 6325		2
55	Parallel pin	904017	16m6x70 DIN 6325		1
61	Breather (incl. part 61.2)	915050			1
61.2	O-ring	901173		*	1
65	Flange plug	90444	R3/8		1
67	Bearing bushing	103003			1
	*) Are included in seal set				

8. FRONT HEAD G 100 TUNNEL

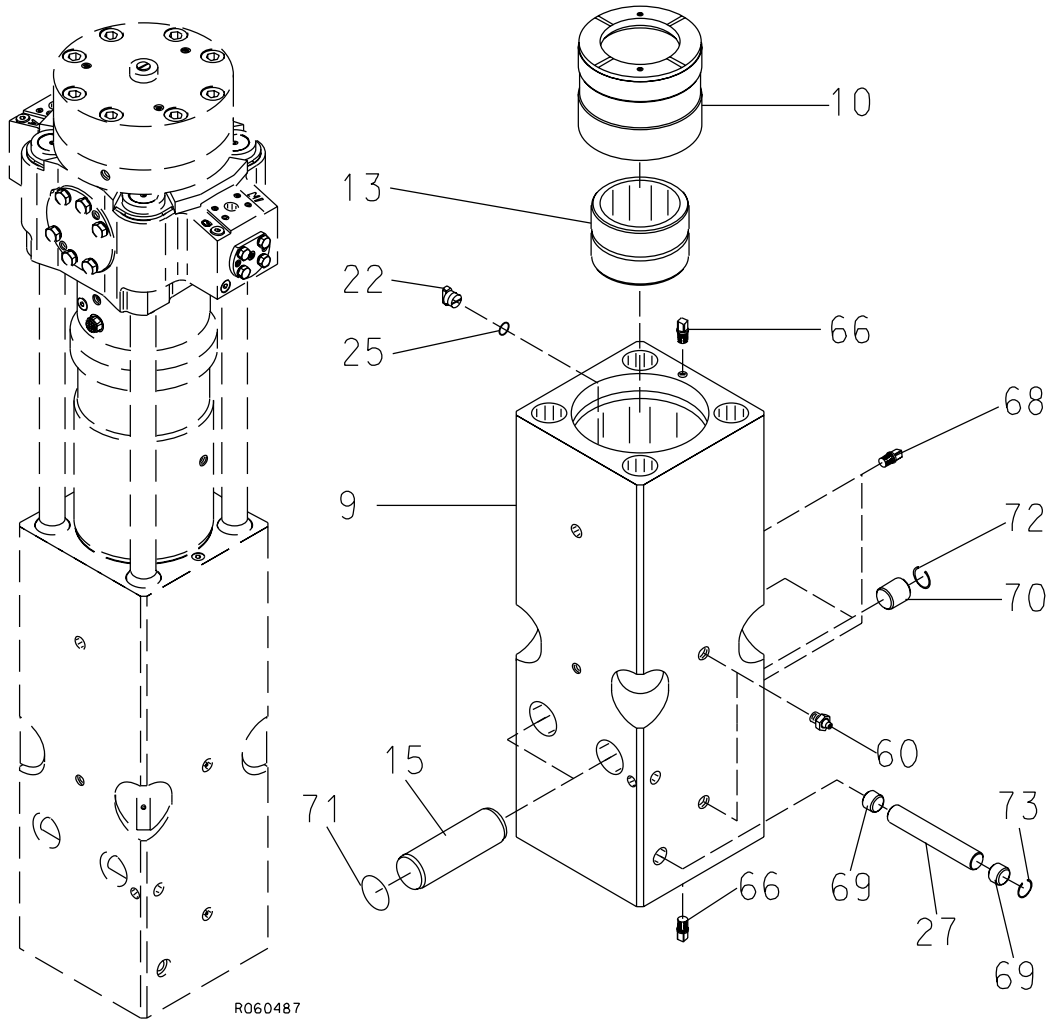

FRONT HEAD G 100 TUNNEL

Item	Description	Part no.	Specification	Note	Qty
9	Front head (incl. parts 66 and 68)	104178			1
10	Thrust ring	200359			1
13	Upper tool bushing	300619			1
15	Tool retaining pin	400470	D80		2
22	Wedge	40110			1
25	O-ring	90000	D24	*	1
27	Retaining pin	400469	D40		1
60	Grease nipple	90200	R1/4		2
66	Plug	111404			2
68	Plug	111399			2
69	Plug	104235			2
70	Plug	104236			2
71	O-ring	902808	D79		2
72	Spring ring	902807	B50 DIN 7993		2
73	Spring ring	902262	B40 DIN 7993		1
	*) Are included in seal set				

9. LOWER TOOL BUSHING G 100 TUNNEL

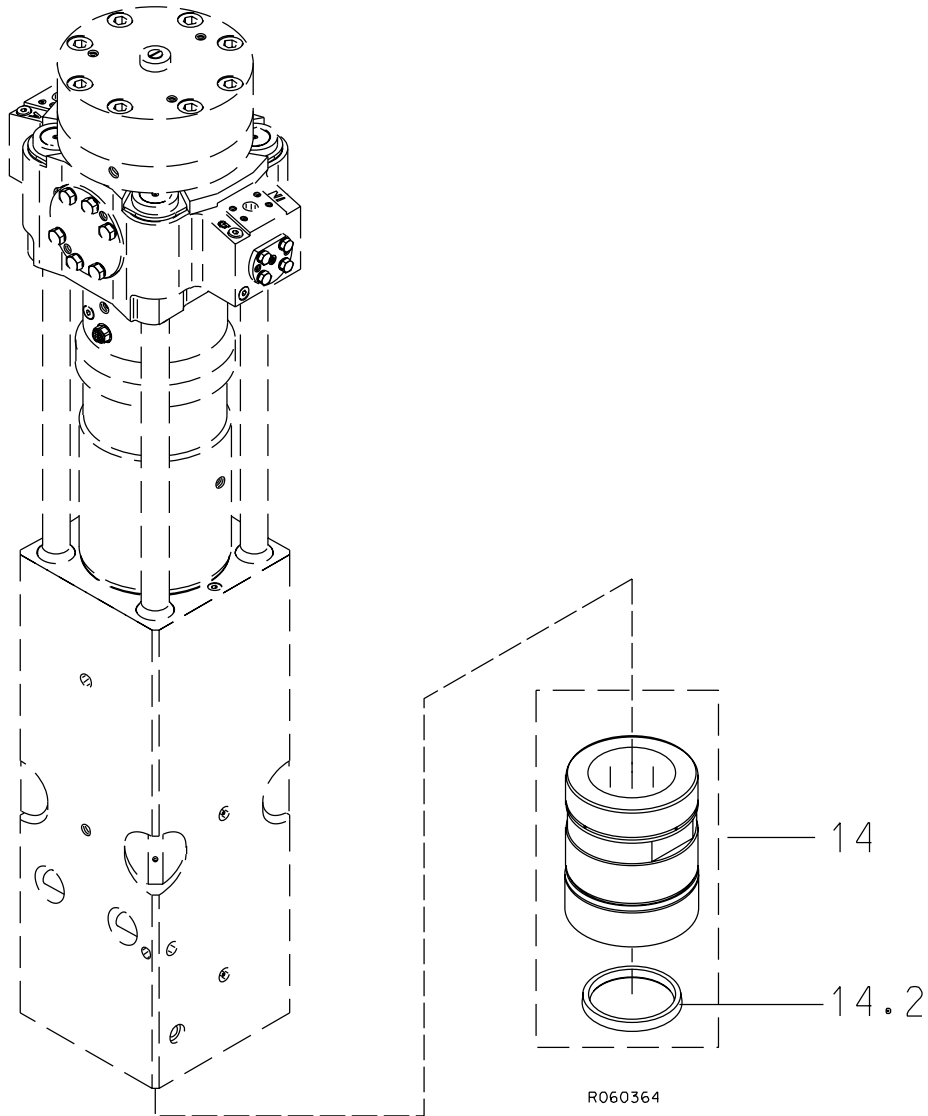

Item	Description	Part no.	Specification	Note	Qty
14	Lower tool bushing (incl. part 14.2)	102159			1
14.2	Seal	102149			1

10. SEAL SET G 100 TUNNEL

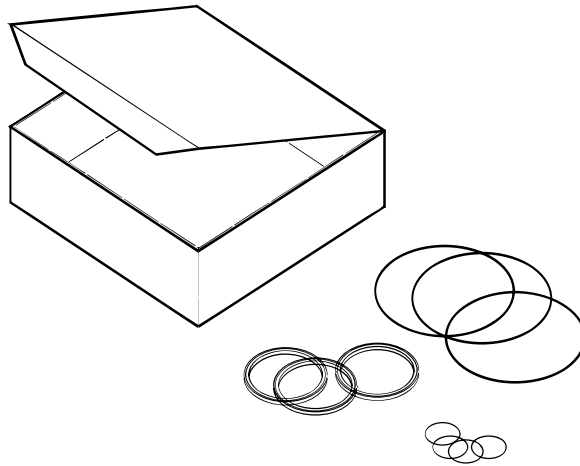

R060012

Item	Name	Part no.	Specification	Note	Qty
Kit	Seal set (incl. parts 1-28)	400568			1
1	O-ring	90000	D24		1
2	Seal	40588	D210		1
3	O-ring	90036	D209		2
4	Seal	903066	D160		1
5	Seal	911023	D142		2
6	Wiper	90065	D160		1
7	Wiper	90064	D142		1
8	Seal	400474	D160		1
9	Seal	400476	D260		1
10	Seal	400481	D280		1
11	O-ring	910015	D269		2
12	O-ring	90012	D19		1
13	O-ring	90011	D14		1
14	O-ring	910018	D21		4
15	O-ring	90032	D120		2
16	O-ring	910013	D117		6
17	Seal	902644			6
18	O-ring	90017	D34		2
20	O-ring	910014	D64		4
21	O-ring	901173			1
22	Seal	40536	D144		1
23	Usit-ring	90056	U8.7-14-1		1
24	O-ring	90030	D75		1
25	Seal	040533	D65		1
26	Seal	41374	D55		1
27	O-ring	90007	D44		1
28	O-ring	910006	D23		1

Sandvik Tamrock Corp., Breakers Lahti
Taivalkatu 8, P.O. Box 165, FIN-15101 Lahti, Finland
Phone Int. +358 205 44 161, Telefax Int. +358 205 44 160
www.rammer.com