

ENG 9/03

PARTS MANUAL
PMG90TENG.903

HYDRAULIC HAMMER

RAMMER G 90 TUNNEL

Serial No.
90BET433-UP

TABLE OF CONTENTS

1. Housing unit G 90 TUNNEL	4
2. Accumulator G 90	6
3. Pilot valve G 90	7
4. Main valve G 90	8
5. Check valve G 90	9
6. Pressure control valve G 90	10
7. Pressure sequence valve G 90	12
8. Tie rods G 90	14
9. Body parts G 90 TUNNEL	16
10. Front head G 90 TUNNEL	18
11. Lower tool bushing G 90	19
12. Seal set G 90 TUNNEL	20

GENUINE RAMMER SPARE PARTS

Rammer genuine spare parts are designed and manufactured by using the latest technological knowledge and engineering skills. Rammer spare parts are made of the best available materials with the most advanced manufacturing techniques.

It is important that you use only genuine Rammer spare parts, to ensure easy operation, maintenance and repair of the product. Please note that eventual warranty claims will be handled only if you have used genuine Rammer parts in your Rammer.

LOCATION OF THE SERIAL NUMBER

It's important to make correct reference to the serial number of the product when ordering spare parts. Identification of serial number is the only proper means of maintaining and identifying parts for a specific product. The location of equipment serial number is pointed in "Operation and maintenance" manual.

SPARE PART ORDERS

Quick spare part deliveries are secured by exact orders.

Required information:

- Name of customer and contact person
 - Order number (when available)
 - Delivery address
 - Mode of delivery (air mail etc.)
 - Required delivery date
 - Invoicing address
 - Model and serial number of the product
 - Name, number and required amount of spare parts
-

PARTS

1. HOUSING UNIT G 90 TUNNEL

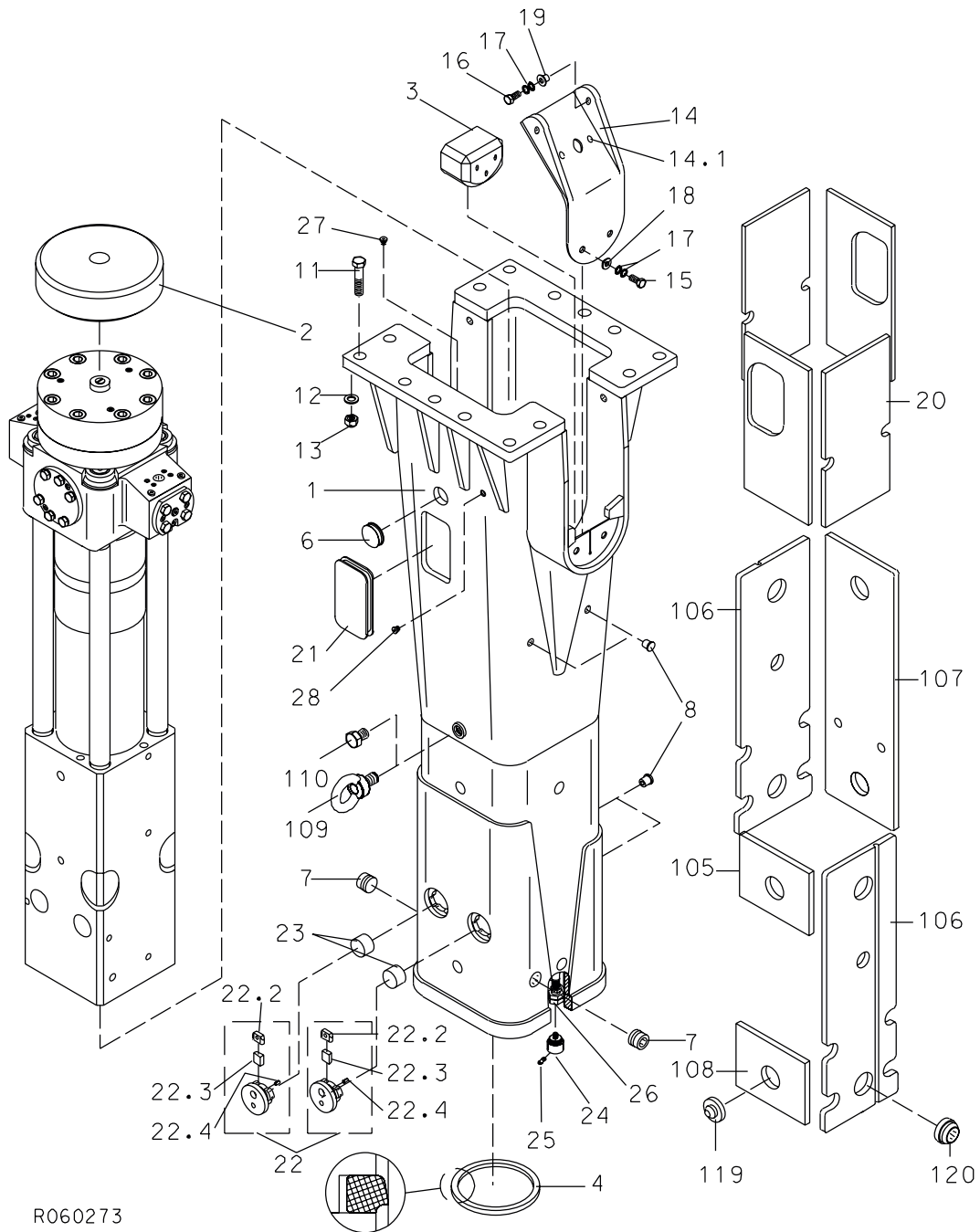

R060273

HOUSING UNIT G 90 TUNNEL

Item	Description	Part no.	Specification	Note	Qty
1	Housing (incl. parts 105-120)	110158			1
2	Buffer	104137			1
3	Pad	104068			2
4	Seal	102328			1
6	Rubber plug	101723	D60		2
7	Rubber plug	400676	D50		2
8	Rubber plug	400566	D25		6
11	Hex. screw	90520	M36x140-8.8 DIN 931		14
12	Washer	90521	37 DIN 6916		14
13	Lock nut	90519	M36-8 DIN 985		14
14	Shield plate (incl. part 14.1)	103850			2
14.1	Plug	103875			2
15	Hex. screw	90513	M12x30-8.8 DIN 933		4
16	Hex. screw	91050	M12x40-8.8 DIN 933		4
17	Lock washer	91012	M12 NORD-LOCK		8
18	Middle bushing	102939			4
19	Middle bushing	102944			4
20	Plate	104085			4
21	Plug	104100			2
22	Cover (incl. parts 22.2-22.4)	106081			2
22.2	Bar	106083			1
22.3	Buffer	106082			1
22.4	Split pin	90327			1
23	Tool retaining pin	110201			2
24	Guide	103047			2
25	Nozzle	102783	SSCO B1/8-GG-SS5		2
26	Hose assembly	103914			1
27	Flange plug	90403	R1/4		1
28	Flange plug	90424	R1/2		1
105	Wear plate	103945			1
106	Wear plate	103946			2
107	Wear plate	103947			1
108	Wear plate	110175			1
109	Lifting eye	90705	M30 DIN 580		1
110	Hex. screw	900026	M30x40-8.8 DIN 933		1
119	Pin	102389			7
120	Pin	102387			1
Kit	Label set	110437			1

2. ACCUMULATOR G 90

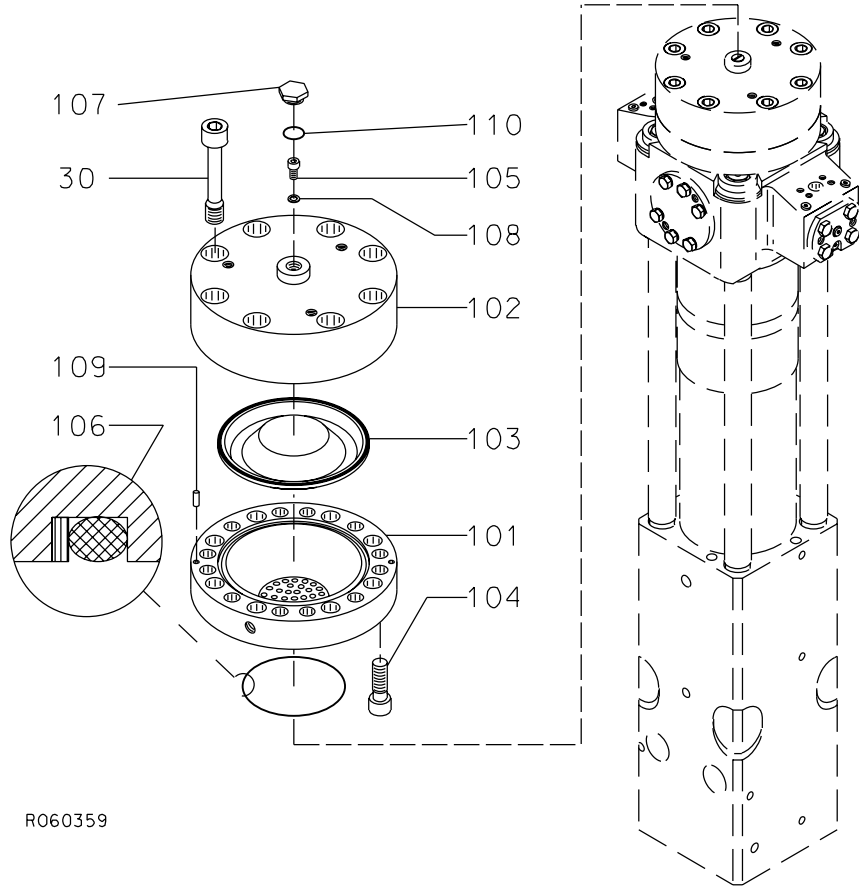

R060359

Item	Description	Part no.	Specification	Note	Qty
1	Accumulator (incl. parts 101-110)	110561			1
101	Accumulator bottom	110560			1
102	Accumulator cover	100491			1
103	Membrane	104022			1
104	Accumulator screw	40528			12
105	Filling plug	40368			1
106	Seal	40536	D144	*	1
107	Shield plug	154015			1
108	Usit-ring	90056	D9	*	1
109	Parallel pin	90304	10m6x24 DIN 6325		2
110	O-ring	910006	D23	*	1
30	Accumulator screw	300711			8
	*) Are included in seal set				

3. PILOT VALVE G 90

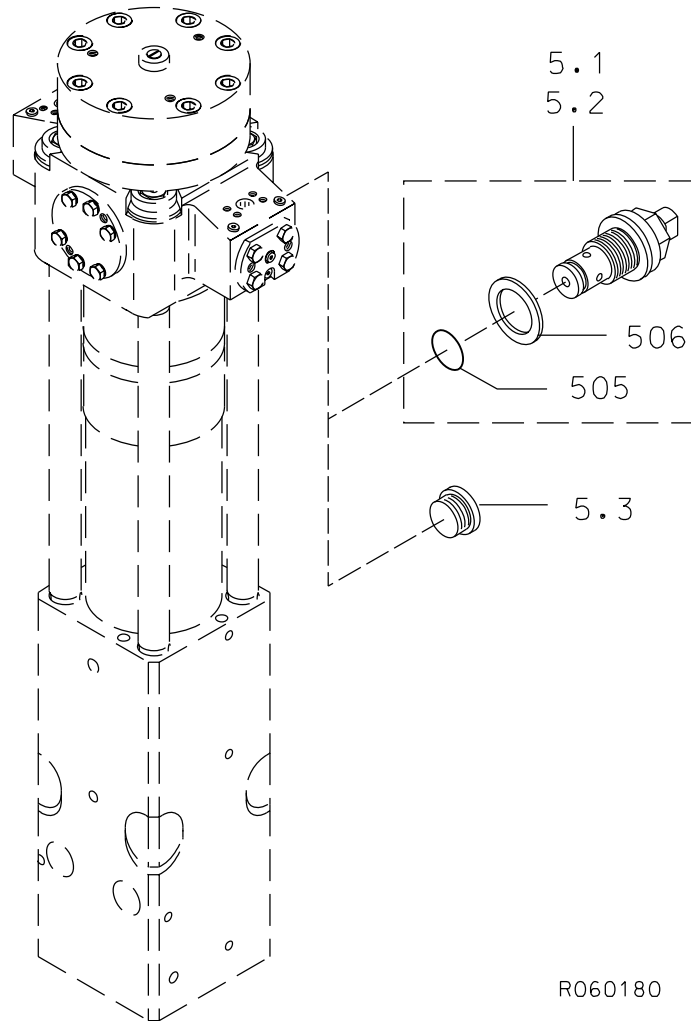

R060180

Item	Description	Part no.	Specification	Note	Qty
5.2	Pilot valve (incl. parts 505-506)	102670	Pressure level 5 (G 90 CITY, S/ N 90ADB5)		1
505	O-ring	901186	D10	*	1
506	Usit-ring	901187	D18	*	1
	*) Are included in seal set				

4. MAIN VALVE G 90

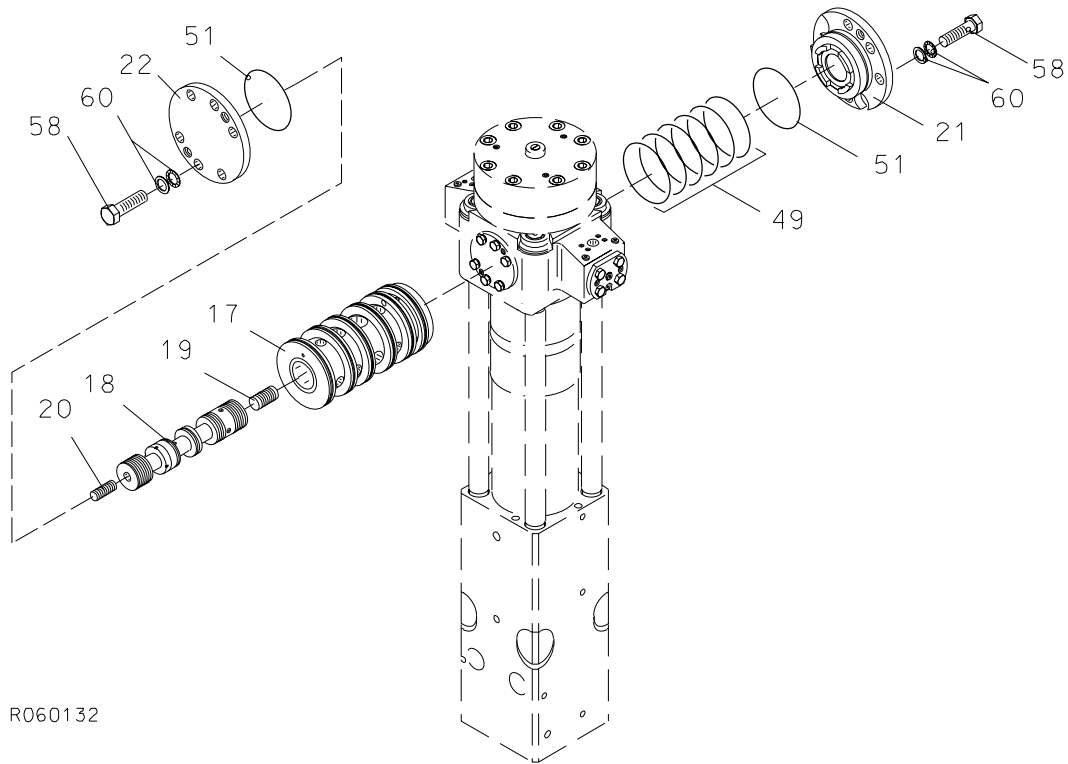

R060132

Item	Description	Part no.	Specification	Note	Qty
17	Main valve bushing	103882			1
18	Main spool	102794			1
19	Spool	102795			1
20	Spool	102796			1
21	Cover	101826			1
22	Cover	30295			1
49	Seal	902644	D125	*	6
51	O-ring	90032	D120	*	2
58	Hex. screw	90569	M20x50-8.8 DIN 933		12
60	Lock washer	91010	M20 NORD-LOCK		12
	*) Are included in seal set				

5. CHECK VALVE G 90

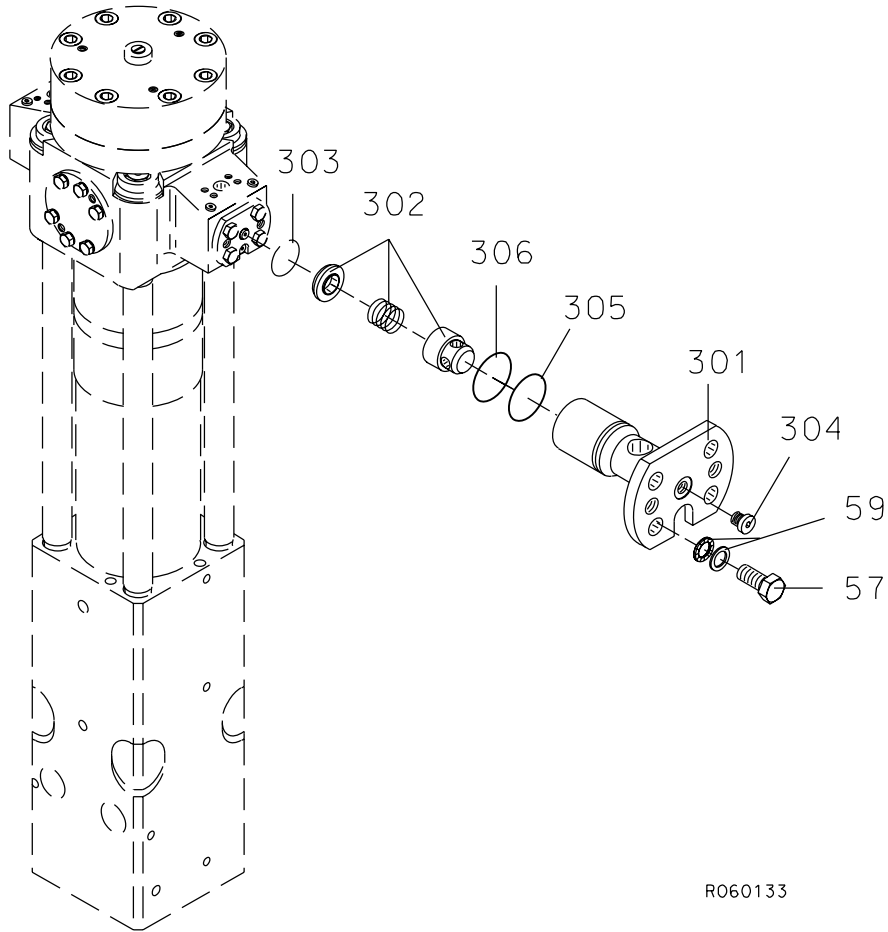

R060133

Item	Description	Part no.	Specification	Note	Qty
3	Check valve (incl. parts 301-306, 57 and 59)	300943			1
301	Check valve housing	300933			1
302	Check valve	90432			1
303	Spring ring	90310	B38 DIN 7993		1
304	Flange plug	90403	R1/4		1
305	O-ring	90031	D46	*	1
306	O-ring	90007	D44	*	1
57	Hex. screw	90517	M16x35-8.8 DIN 933		4
59	Lock washer	90597	M16 NORD-LOCK		4
	*) Are included in seal set				

6. PRESSURE CONTROL VALVE G 90

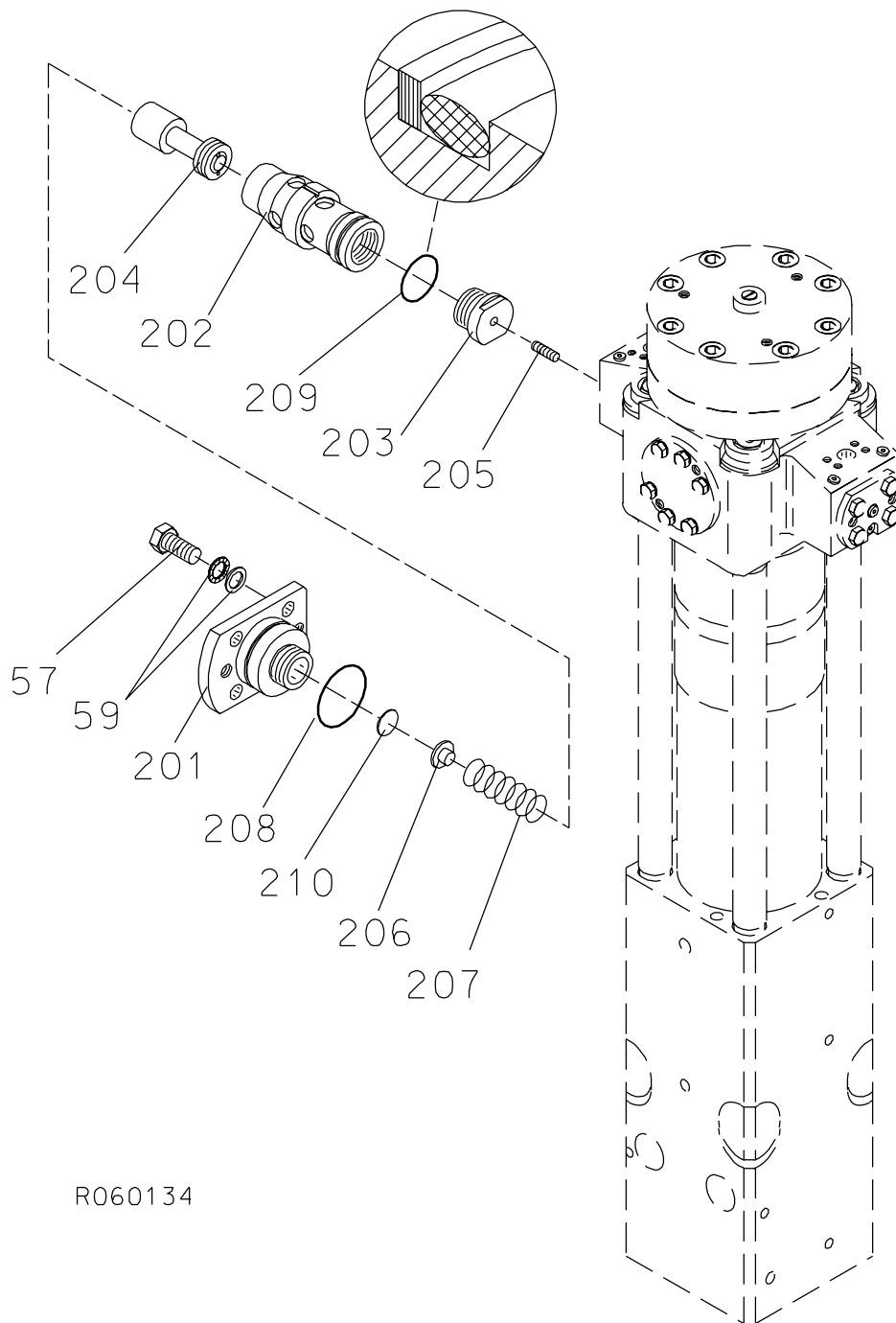

R060134

PRESSURE CONTROL VALVE G 90

Item	Description	Part no.	Specification	Note	Qty
2	Pressure control valve (incl. parts 201-210, 57 and 59)	103313			1
201	Cover	103311			1
202	Valve housing	104010			1
203	Guide	400581			1
204	Spool	300866			1
205	Spool	400582			1
206	Spring guide	42174			1
207	Spring	90118			1
208	O-ring	90030	D75	*	1
209	Seal	41374	D55	*	1
210	Shim plate	42363	S=0.9		x
210	Shim plate	42362	S=1.25		x
210	Shim plate	42361	S=1.5		x
57	Hex. screw	90517	M16x35-8.8 DIN 933		4
59	Lock washer	90597	M16 NORD-LOCK		4
	*) Are included in seal set				

7. PRESSURE SEQUENCE VALVE G 90

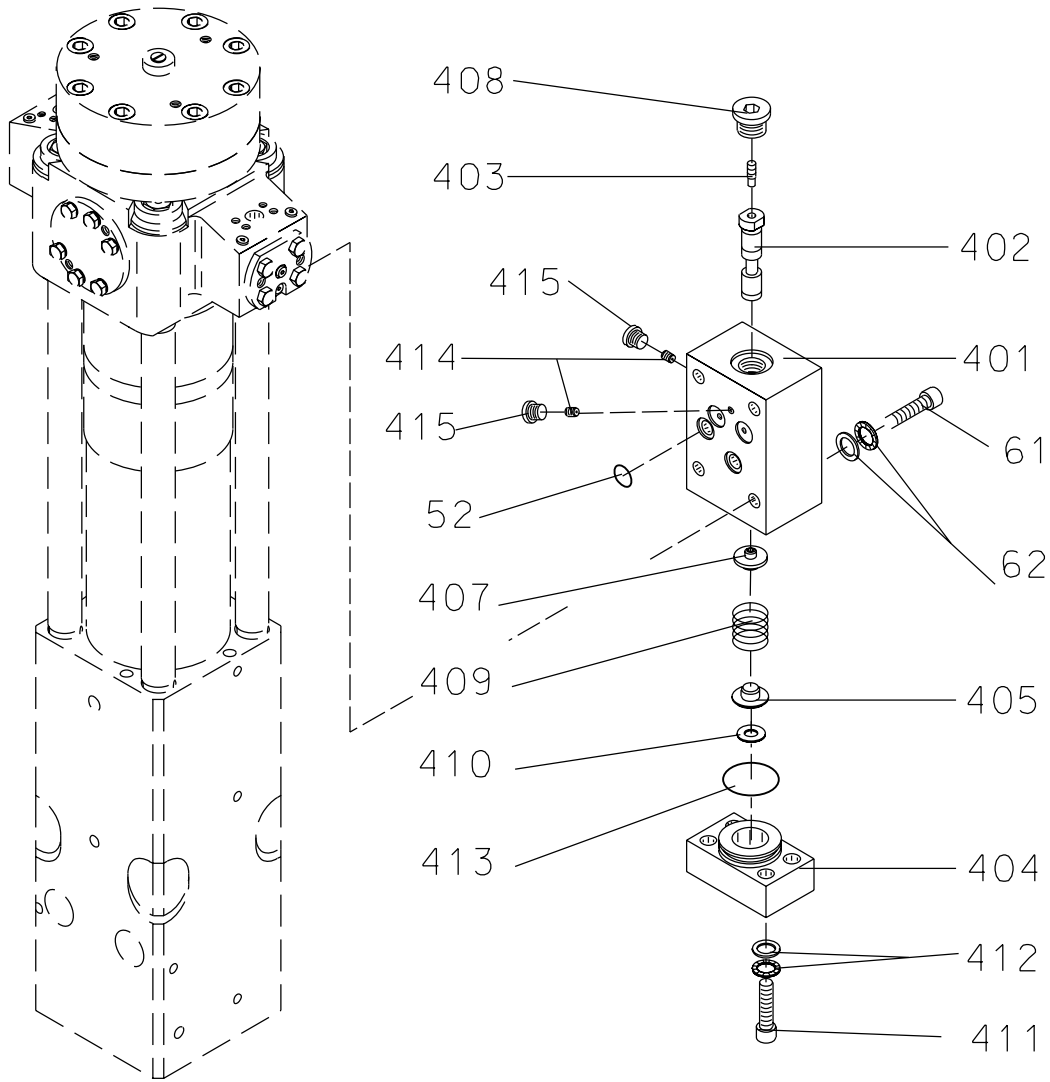

R060135

Item	Description	Part no.	Specification	Note	Qty
4	Pressure sequence valve (incl. parts 401-415, 61 and 62)	102797			1
401	Valve housing	102798			1
402	Spool	102130			1
403	Spool	101579			1
404	Spring housing	103310			1

PRESSURE SEQUENCE VALVE G 90

Item	Description	Part no.	Specification	Note	Qty
405	Spring guide	40275			1
407	Spring guide	101580			1
408	Flange plug	90424	R1/2		1
409	Spring	90110	D25x64		1
410	Shim plate	42364	S=1.5		x
410	Shim plate	42365	S=1.25		x
410	Shim plate	42366	S=0.9		x
411	Hex. socket screw	90522	M12x40-12.9 DIN 912		4
412	Lock washer	91012	M12 NORD-LOCK		4
413	O-ring	94091	D39	*	1
414	Nozzle	101466			2
415	Flange plug	93203	R1/8		2
52	O-ring	901942	D16	*	4
61	Hex. socket screw	902954	M12x50-12.9 DIN 912		4
62	Lock washer	91012	M12 NORD-LOCK		4
	*) Are included in seal set				

8. TIE RODS G 90

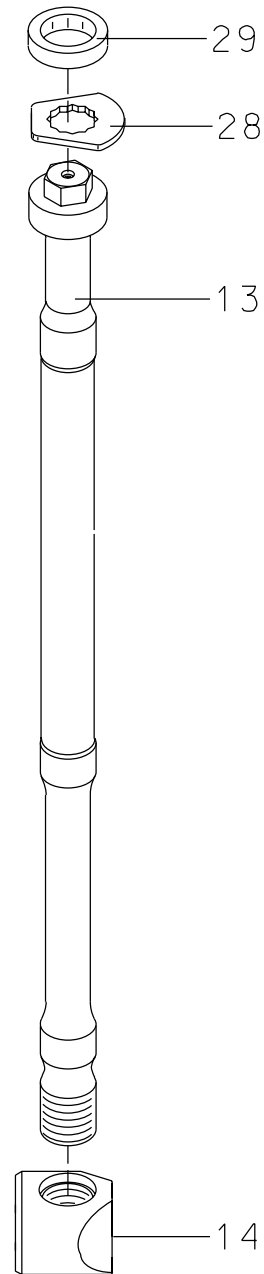
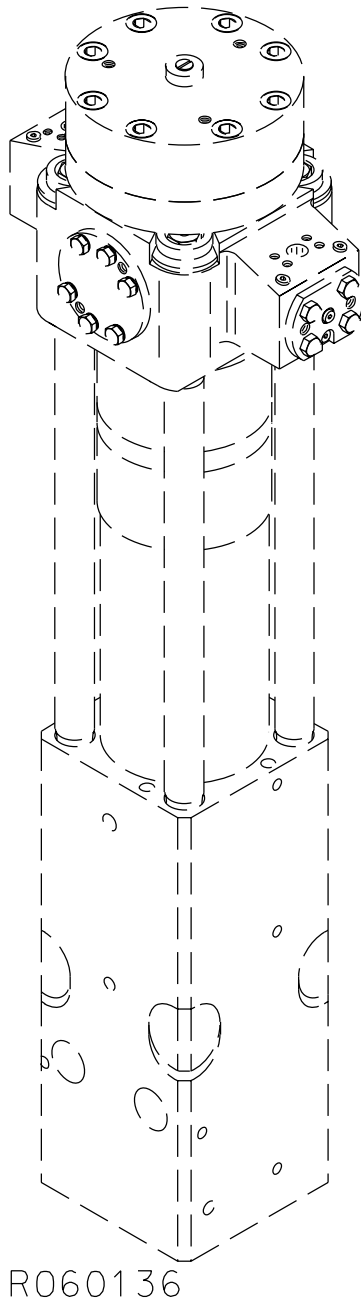

TIE RODS G 90

Item	Description	Part no.	Specification	Note	Qty
13	Tie rod	103747			4
14	Tie rod nut	103749			4
28	Lock plate	101772			4
29	Rubber ring	40586			4

9. BODY PARTS G 90 TUNNEL

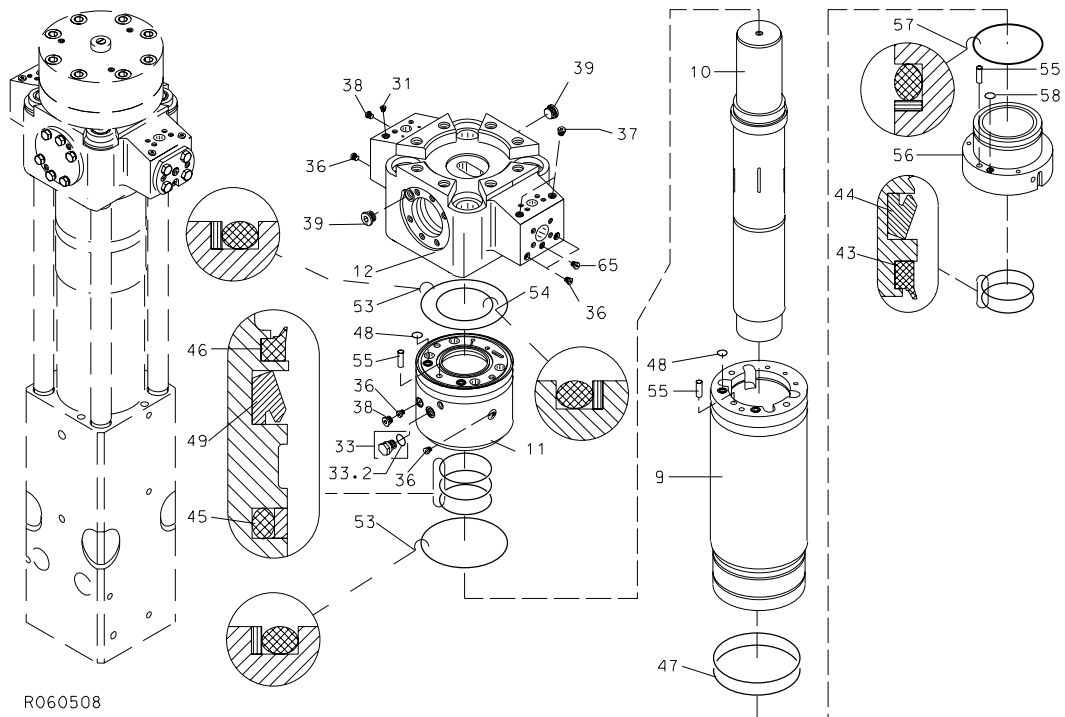

R060508

BODY PARTS G 90 TUNNEL

Item	Description	Part no.	Specification	Note	Qty
9	Cylinder	110316			1
10	Piston	102792			1
11	Seal carrier (incl. parts 33, 36 and 38)	154800			1
12	Valve body (incl. parts 33, 36, 37, 38, 39 and 65)	104039			1
31	Breather	400662			1
33	Breather (incl. part 33.2)	101700			1
33.2	O-ring	901173	D27	*	1
36	Flange plug	90403	R1/4		5
37	Flange plug	90444	R3/8		2
38	Flange plug	90424	R1/2		2
39	Flange plug	90410	R1		2
43	Wiper	901403	D148	*	1
44	Seal	951093	D148	*	1
45	Seal	41192	D130	*	1
46	Wiper	41194	D130	*	1
47	O-ring	90003	D239	*	2
48	O-ring	90012	D19	*	4
49	Seal	902775	D130	*	2
53	Seal	101774	D270	*	2
54	Seal	41141	D143	*	1
55	Parallel pin	90317	16m6x50 DIN 6325		3
56	Seal carrier	110325			1
57	Seal	110358		*	1
58	O-ring	90011	D14	*	1
65	Plug	41658			1
	*) Are included in seal set				

10. FRONT HEAD G 90 TUNNEL

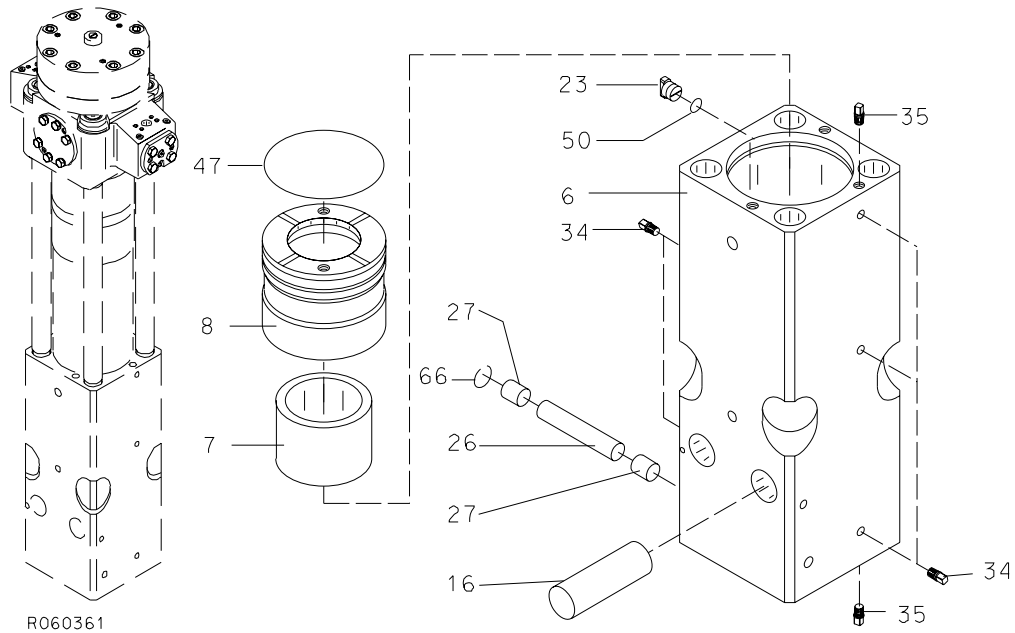

Item	Description	Part no.	Specification	Note	Qty
6	Front head (incl. parts 34 and 35)	110535			1
7	Upper tool bushing	102789			1
8	Thrust ring	102790			1
16	Tool retaining pin	101769			1
23	Wedge	40110			1
26	Retaining pin	110494			1
27	Plug	104235			2
34	Plug	111399			5
35	Plug	111402			2
47	O-ring	90003	D239	*	1
50	O-ring	90000	D24	*	1
66	Spring ring	902262	B40 DIN 7993		1
	*) Are included in seal set				

11. LOWER TOOL BUSHING G 90

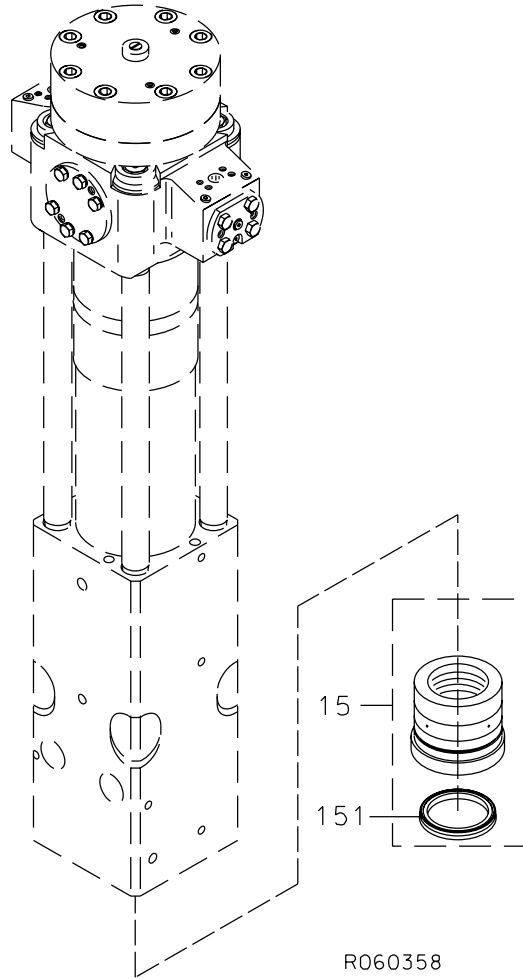

R060358

Item	Description	Part no.	Specification	Note	Qty
15	Lower tool bushing (incl. part 151)	103131			1
151	Seal	102322			1

12. SEAL SET G 90 TUNNEL

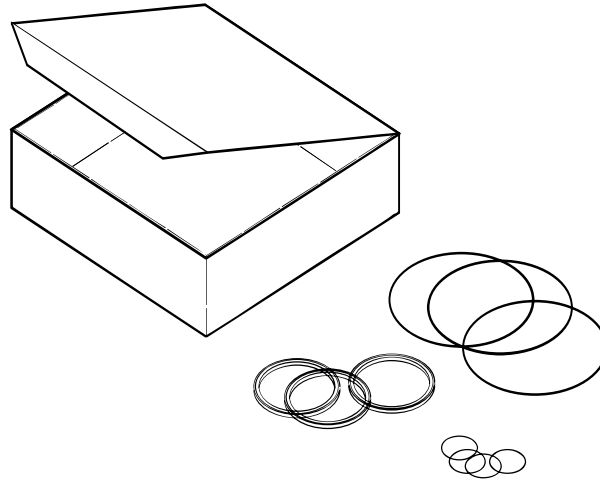

R060012

Item	Description	Part no.	Specification	Note	Qty
Kit	Seal set (incl. parts 1-27)	106638			1
1	O-ring	901173			1
2	Wiper	901403	D148		1
3	Seal	951093	D148		1
4	Seal	110311	D130		1
5	Seal	902775	D130		1
6	Wiper	41194	D130		1
7	O-ring	90003	D239		3
8	O-ring	90012	D19		4
9	O-ring	90011	D14		1
10	Seal	110358			1
11	Seal	902644	D125		6
12	O-ring	90000	D24		1
13	O-ring	90032	D120		2
14	O-ring	901942	D16		4
15	Seal	101774	D270		2
16	Seal	41141	D143		1
17	Seal	40536	D144		1
18	Usit-ring	90056	D9		1
20	O-ring	90030	D75		1
21	Seal	41374	D55		1
22	O-ring	90031	D46		1
23	O-ring	90007	D44		1
24	O-ring	94091	D39		1
25	O-ring	901186	D10		1
26	Usit-ring	901187	D18		1
27	Seal	41192	D130		1

Sandvik Tamrock Corp., Breakers Lahti
Taivalkatu 8, P.O. Box 165, FIN-15101 Lahti, Finland
Phone Int. +358 205 44 161, Telefax Int. +358 205 44 160
www.rammer.com