

**PARTS MANUAL**  
**PMG110CCENG.903**

**HYDRAULIC HAMMER**  
**RAMMER G 110 CITY**  
**RAMMER G 110 CITY-JET**  
**RAMMER G 110 CITY PRO**

**Serial No.**

**11ADB5057-UP**

**11AEB5005-UP**

**11APB6057-UP**

---

## TABLE OF CONTENTS

1. Housing unit G 110 CITY .....	4
2. Housing unit G 110 CITY-JET, CITY PRO .....	6
3. Accumulator G 110 .....	8
4. Pilot valve G 110 .....	9
5. Main valve G 110 .....	10
6. Check valve G 110 .....	11
7. Pressure control valve G 110 .....	12
8. Pressure sequence valve G 110 .....	14
9. Tie rods G 110 .....	16
10. Body parts G 110 .....	18
11. Front head G 110 .....	20
12. Lower tool bushing G 110 .....	21
13. Seal set G 110 .....	22

---

## GENUINE RAMMER SPARE PARTS

Rammer genuine spare parts are designed and manufactured by using the latest technological knowledge and engineering skills. Rammer spare parts are made of the best available materials with the most advanced manufacturing techniques.

It is important that you use only genuine Rammer spare parts, to ensure easy operation, maintenance and repair of the product. Please note that eventual warranty claims will be handled only if you have used genuine Rammer parts in your Rammer.

## LOCATION OF THE SERIAL NUMBER

It's important to make correct reference to the serial number of the product when ordering spare parts. Identification of serial number is the only proper means of maintaining and identifying parts for a specific product. The location of equipment serial number is pointed in "Operation and maintenance" manual.

## SPARE PART ORDERS

Quick spare part deliveries are secured by exact orders.

### Required information:

- Name of customer and contact person
  - Order number (when available)
  - Delivery address
  - Mode of delivery (air mail etc.)
  - Required delivery date
  - Invoicing address
  - Model and serial number of the product
  - Name, number and required amount of spare parts
-

---

---

# **PARTS**

---

**1. HOUSING UNIT G 110 CITY**

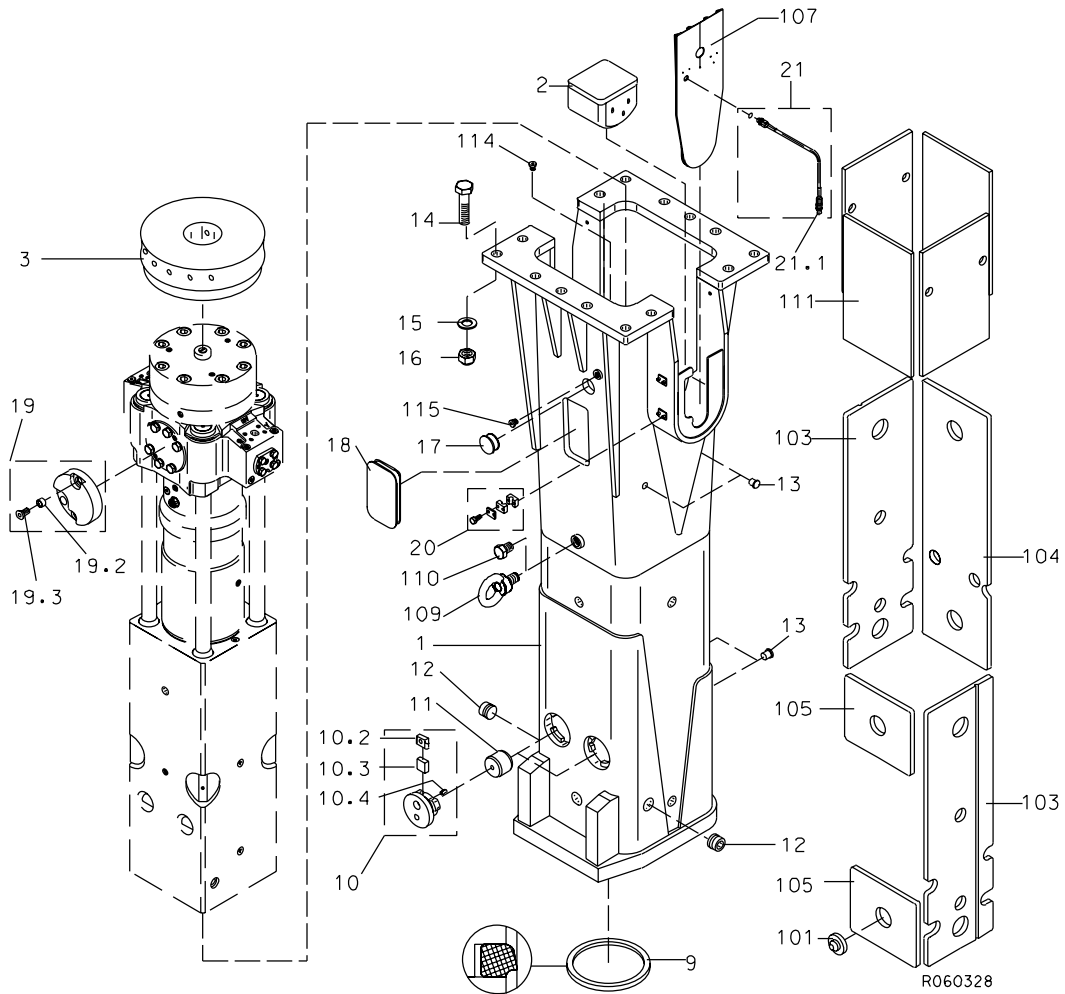

Item	Description	Part no.	Specification	Note	Qty
1	Housing (incl. parts 101-115)	106882			1
2	Pad	104068			2
3	Buffer	104137			1
9	Seal	102144	D264		1
10	Cover (incl. parts 10.2-10.4)	106081			2
10.2	Bar	106083			1
10.3	Flexible element	106082			1
10.4	Split pin	90327	6x16 DIN 7343		1
11	Pin	105760			2

**HOUSING UNIT G 110 CITY**

<b>Item</b>	<b>Description</b>	<b>Part no.</b>	<b>Specification</b>	<b>Note</b>	<b>Qty</b>
12	Rubber plug	400676			2
13	Rubber plug	400566			6
14	Hex. screw	90520	M36x140-8.8 DIN 931		14
15	Washer	90521	37 DIN 6916		14
16	Lock nut	90519	M36-8 DIN 985		14
17	Rubber plug	101724			2
18	Rubber plug	105782			2
19	Damper parts (incl. parts 19.2-19.3)	105785			2
19.2	Bushing	105787			2
19.3	Hex. socket screw	901287	M20x40-8.8 DIN 7991		2
20	Pipe clamping	106251			2
21	Hose assembly (incl. part 21.1)	110499			1
21.1	Grease nipple	90200			1
101	Pin	102389			8
103	Wear plate	104126			2
104	Wear plate	104125			1
105	Wear plate	104124			2
107	Shield plate	105780			2
109	Lifting eye bolt	901464	M36 DIN 580		1
110	Hex. screw	901465	M36x40-8.8 DIN933		1
111	Damper plate	102564			4
114	Flange plug	90403	G1/4		1
115	Flange plug	90424	G1/2		1
Kit	Label set	110615			1

2. HOUSING UNIT G 110 CITY-JET, CITY PRO

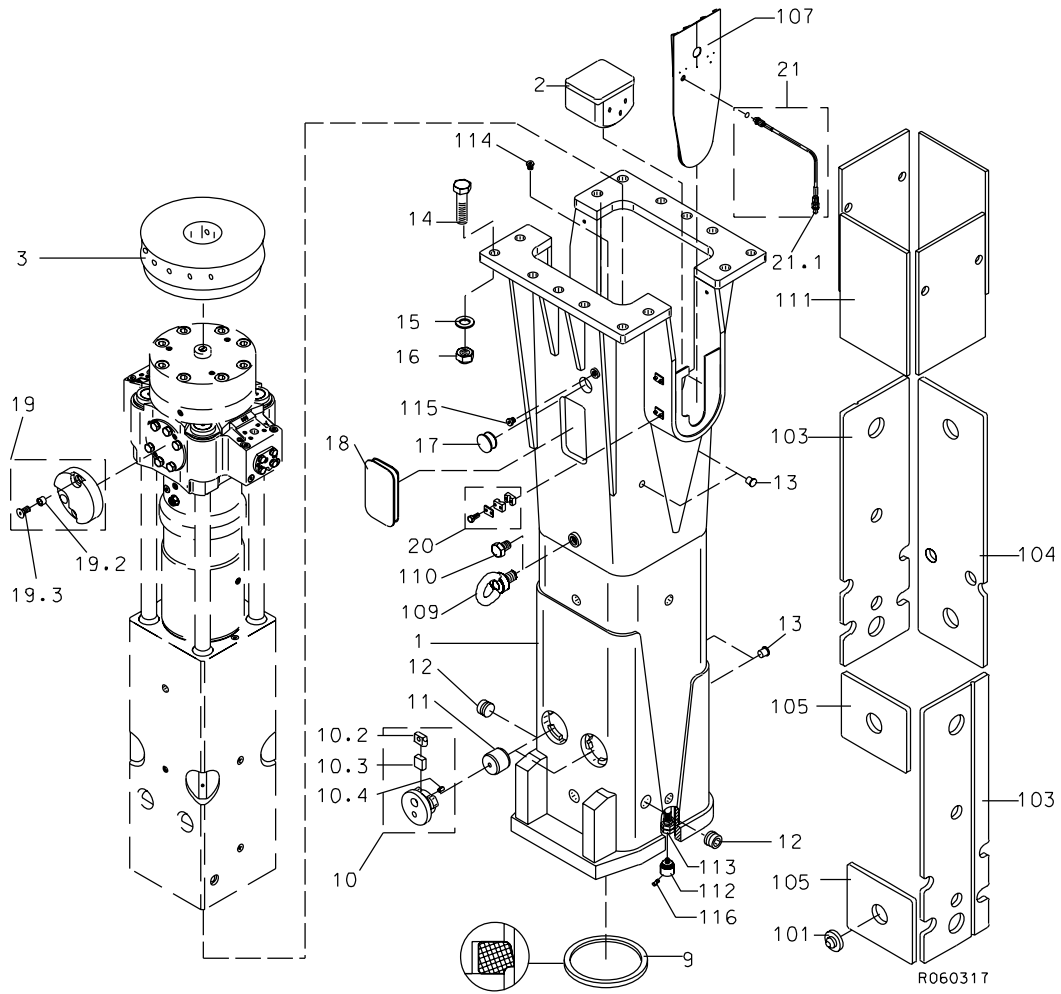

Item	Description	Part no.	Specification	Note	Qty
1	Housing (incl. parts 101-116)	105770			1
2	Pad	104068			2
3	Buffer	104137			1
9	Seal	102144	D264		1
10	Cover (incl. parts 10.2-10.4)	106081			2
10.2	Bar	106083			1
10.3	Flexible element	106082			1
10.4	Split pin	90327	6x16 DIN 7343		1
11	Pin	105760			2

**HOUSING UNIT G 110 CITY-JET, CITY PRO**

<b>Item</b>	<b>Description</b>	<b>Part no.</b>	<b>Specification</b>	<b>Note</b>	<b>Qty</b>
12	Rubber plug	400676			2
13	Rubber plug	400566			6
14	Hex. screw	90520	M36x140-8.8 DIN 931		14
15	Washer	90521	37 DIN 6916		14
16	Lock nut	90519	M36-8 DIN 985		14
17	Rubber plug	101724			2
18	Rubber plug	105782			2
19	Damper parts (incl. parts 19.2-19.3)	105785			2
19.2	Bushing	105787			2
19.3	Hex. socket screw	901287	M20x40-8.8 DIN 7991		2
20	Pipe clamping	106251			2
21	Hose assembly (incl. part 21.1)	110499			1
21.1	Grease nipple	90200			1
101	Pin	102389			8
103	Wear plate	104126			2
104	Wear plate	104125			1
105	Wear plate	104124			2
107	Shield plate	105780			2
109	Lifting eye bolt	901464	M36 DIN 580		1
110	Hex. screw	901465	M36x40-8.8 DIN933		1
111	Damper plate	102564			4
112	Guide	104383			2
113	Hose assembly	106186			1
114	Flange plug	90403	G1/4		1
115	Flange plug	90424	G1/2		1
116	Nozzle	104534			2
Kit	Label set	152855	For G 110 CITY PRO		1
Kit	Label set	154760	For G 110 CITY JET		1

3. ACCUMULATOR G 110

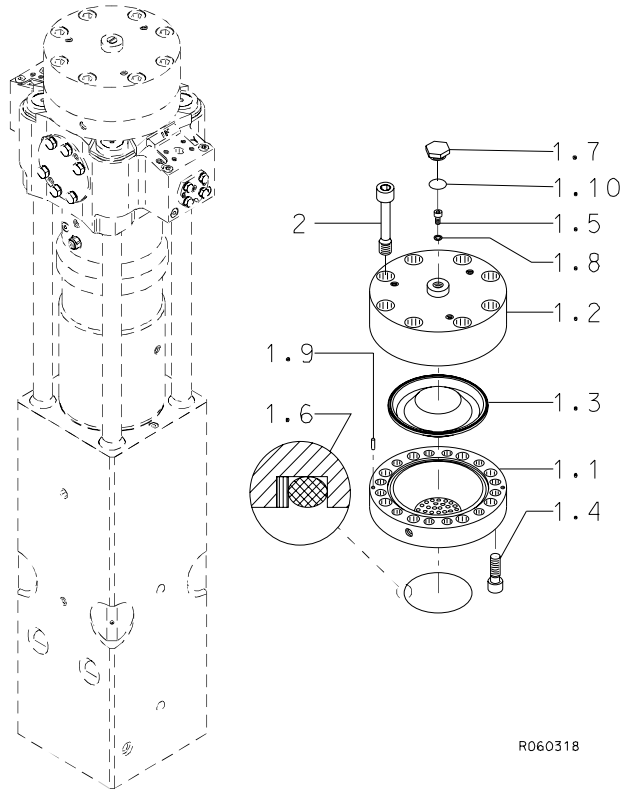

Item	Description	Part no.	Specification	Note	Qty
1	Accumulator (incl. parts 1.1-1.10)	110561			1
1.1	Accumulator bottom	110560			1
1.2	Accumulator cover	100491			1
1.3	Membrane	104022			1
1.4	Accumulator screw	40528			12
1.5	Filling plug	40368			1
1.6	Seal	40536	D145	*	1
1.7	Shield plug	154015			1
1.8	Usit-ring	90056	D9	*	1
1.9	Parallel pin	90304	10m6x24 DIN 6325		2
1.10	O-ring	910006	D23	*	1
2	Accumulator screw	300711			8
	*) Are included in seal set				



## 4. PILOT VALVE G 110

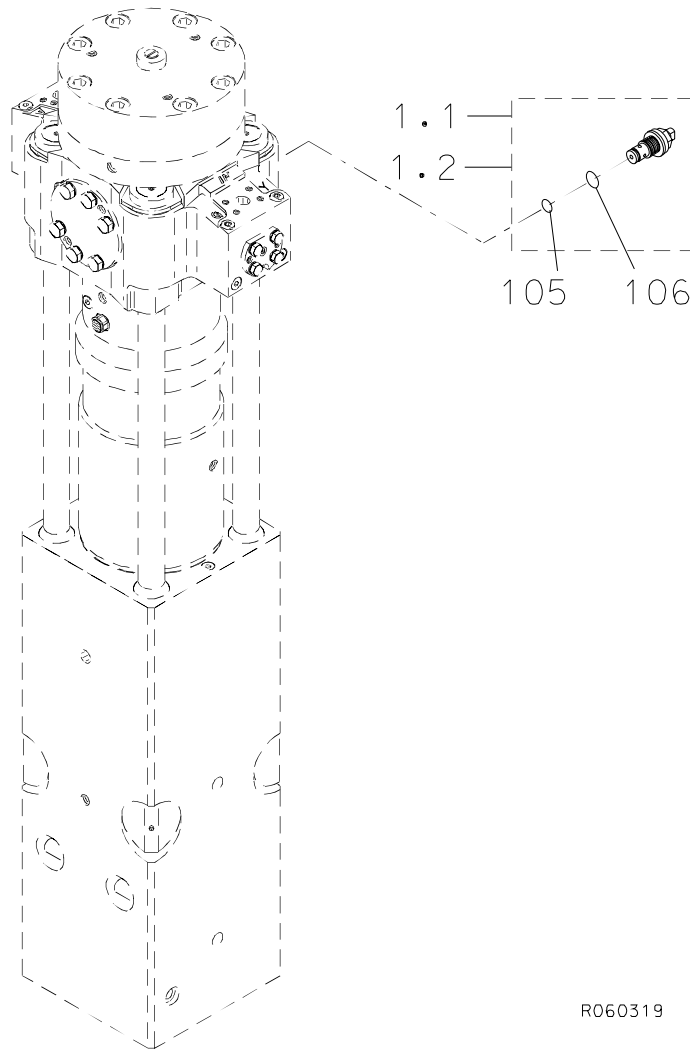

R060319

Item	Description	Part no.	Specification	Note	Qty
1.1	Pilot valve (incl. parts 105-106)	101598	Pressure level 6 (G 110 CITY PRO, S/N 11APB6)		1
1.2	Pilot valve (incl. parts 105-106)	102670	Pressure level 5 (G 110 CITY, S/N 11ADB5)		1
105	O-ring	901186	D10	*	1
106	Usit-ring	901187	D18	*	1
	*) Are included in seal set				

**5. MAIN VALVE G 110**

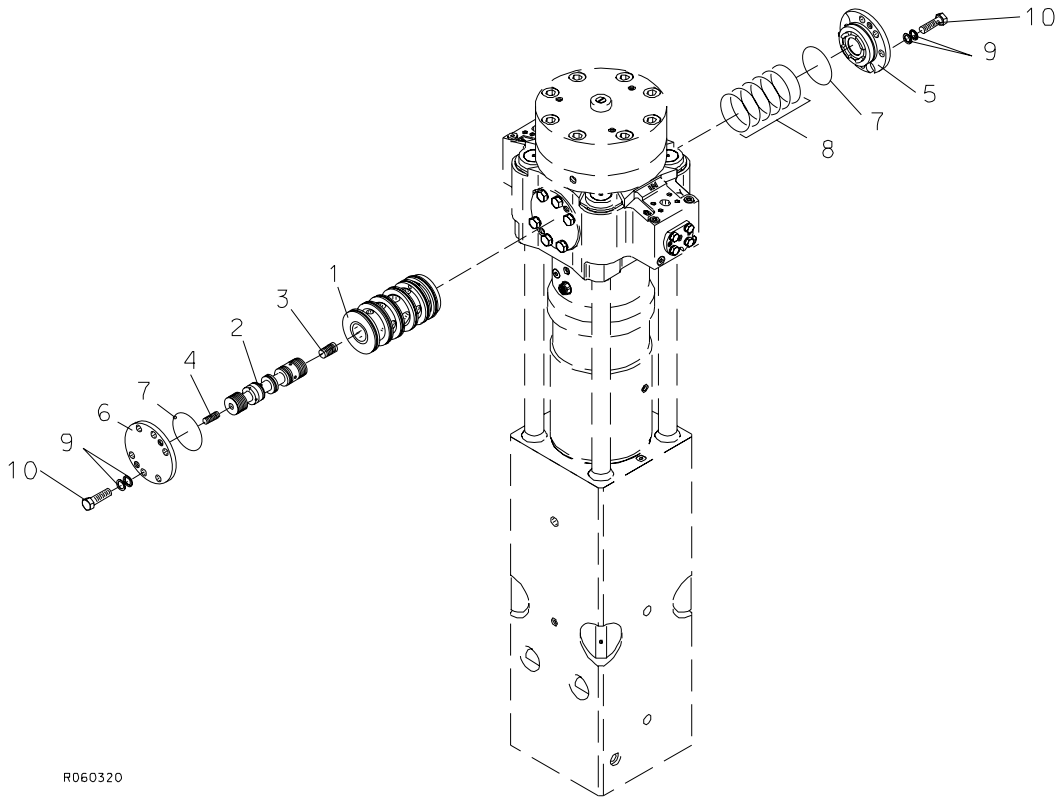

R060320

Item	Description	Part no.	Specification	Note	Qty
1	Main valve bushing	103882			1
2	Main spool	153261			1
3	Spool	102795			1
4	Spool	102796			1
5	Cover	101826			1
6	Cover	30295			1
7	O-ring	90032	D120	*	2
8	Seal	902644		*	6
9	Lock washer	91010	M20 NORD-LOCK		12
10	Hex. screw	900036	M20x70-10.9 DIN 931		12
	*) Are included in seal set				

6. CHECK VALVE G 110

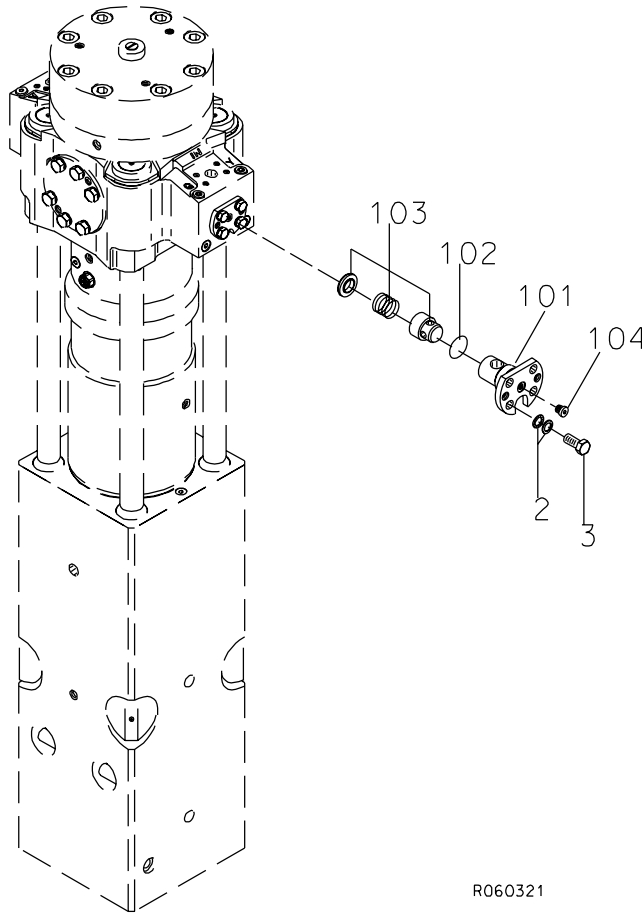

R060321

Item	Description	Part no.	Specification	Note	Qty
1	Check valve (incl. parts 101-104)	105800			1
101	Cover	105763			1
102	O-ring	90007	D44	*	1
103	Check valve	915077			1
104	Flange plug	90403	G1/4		1
2	Lock washer	90597	M16 NORD-LOCK		4
3	Hex. screw	90517	M16x35-8.8 DIN 933		4
	*) Are included in seal set				

**7. PRESSURE CONTROL VALVE G 110**

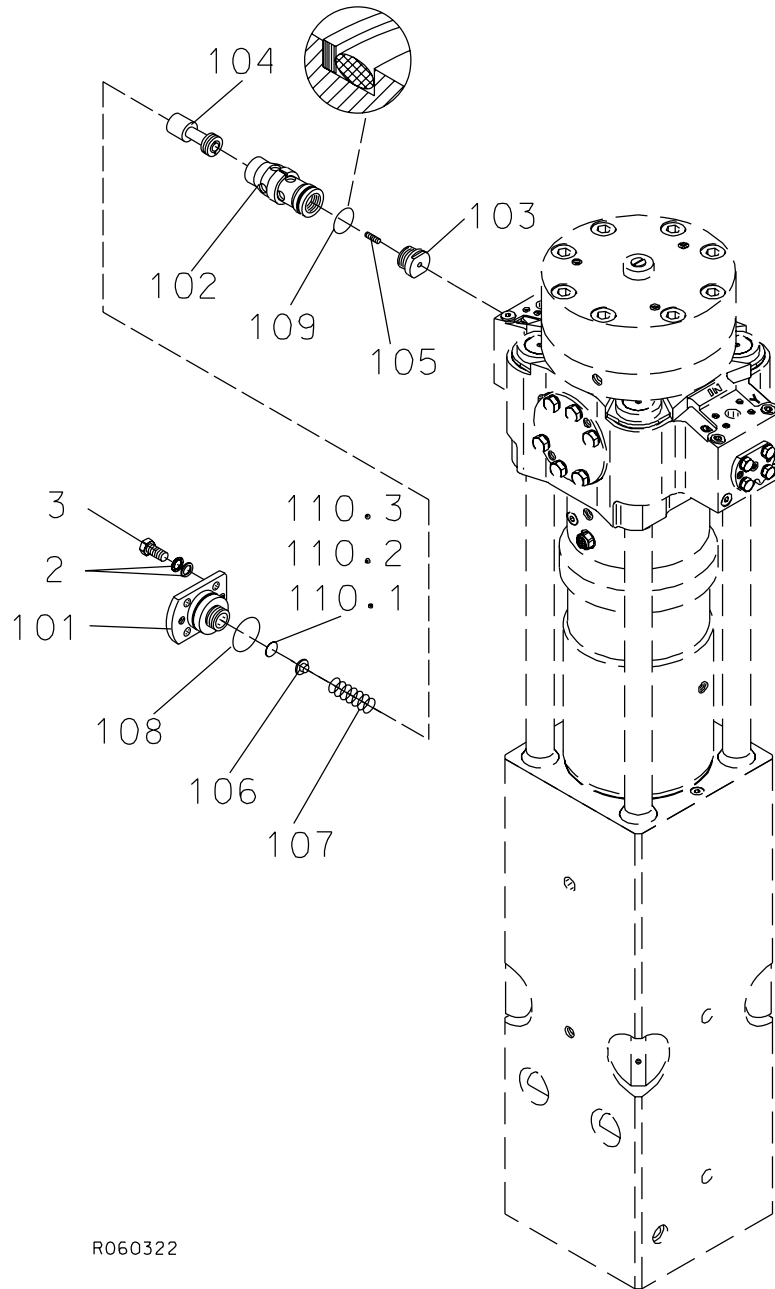

R060322

**PRESSURE CONTROL VALVE G 110**

<b>Item</b>	<b>Description</b>	<b>Part no.</b>	<b>Specification</b>	<b>Note</b>	<b>Qty</b>
1	Pressure control valve (incl. parts 101-110, 2 and 3)	153616			1
101	Cover	103311			1
102	Valve housing	104010			1
103	Guide	400581			1
104	Spool	300866			1
105	Spool	400582			1
106	Spring guide	42174			1
107	Spring	90118			1
108	O-ring	90030	D75	*	1
109	Seal	41374	D55	*	1
110.1	Shim plate	42363	S=1		1
110.2	Shim plate	42362	S=1.25		1
110.3	Shim plate	42361	S=1.5		1
2	Lock washer	90597	M16 NORD-LOCK		4
3	Hex. screw	90517	M16x35-8.8 DIN 933		4
	*) Are included in seal set				

**8. PRESSURE SEQUENCE VALVE G 110**

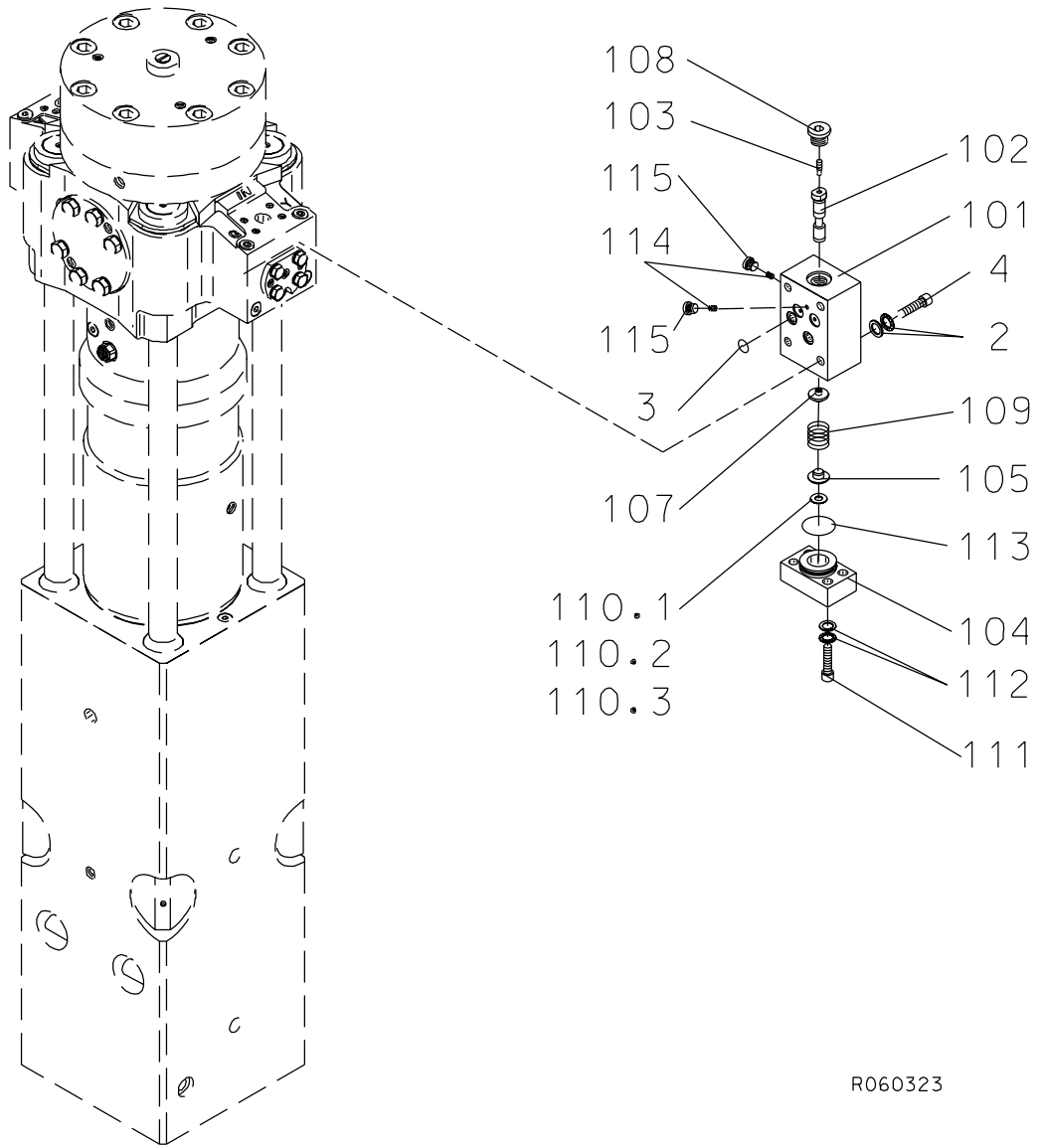

R060323

**PRESSURE SEQUENCE VALVE G 110**

<b>Item</b>	<b>Description</b>	<b>Part no.</b>	<b>Specification</b>	<b>Note</b>	<b>Qty</b>
1	Pressure sequence valve (incl. parts 101-115, 2, 3 and 4)	102797			1
101	Valve housing	102798			1
102	Spool	102130			1
103	Spool	101579			1
104	Spring housing	103310			1
105	Spring guide	40275			1
107	Spring guide	101580			1
108	Flange plug	90424	G1/2		1
109	Spring	90110			1
110.1	Shim plate	42364			1
110.2	Shim plate	42365			1
110.3	Shim plate	42366			1
111	Hex. socket screw	90522	M12x40-12.9 DIN 912		4
112	Lock washer	91012	M12 NORD-LOCK		4
113	O-ring	94091	D39	*	1
114	Nozzle	101466			2
115	Flange plug	93203	G1/8		2
2	Lock washer	91012	M12 NORD-LOCK		4
3	O-ring	901942	D16	*	4
4	Hex. socket screw	902954	M12x50-12.9 DIN 912		4
	*) Are included in seal set				

## 9. TIE RODS G 110

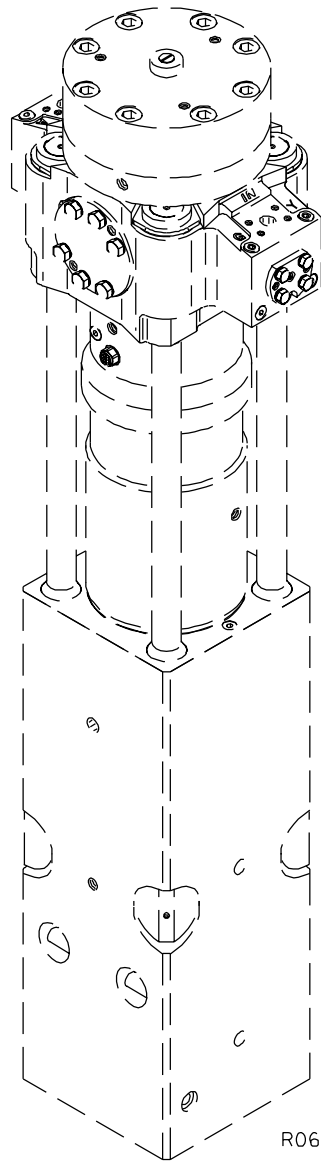

R060324

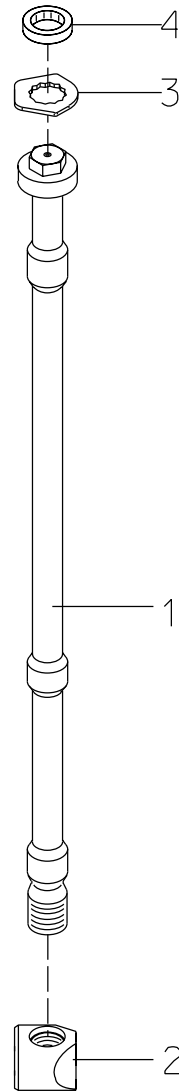



**TIE RODS G 110**

---

<b>Item</b>	<b>Description</b>	<b>Part no.</b>	<b>Specification</b>	<b>Note</b>	<b>Qty</b>
1	Tie rod	103777			4
2	Tie rod nut	105618			4
3	Lock plate	400478			4
4	Rubber ring	40586			4

**10. BODY PARTS G 110**

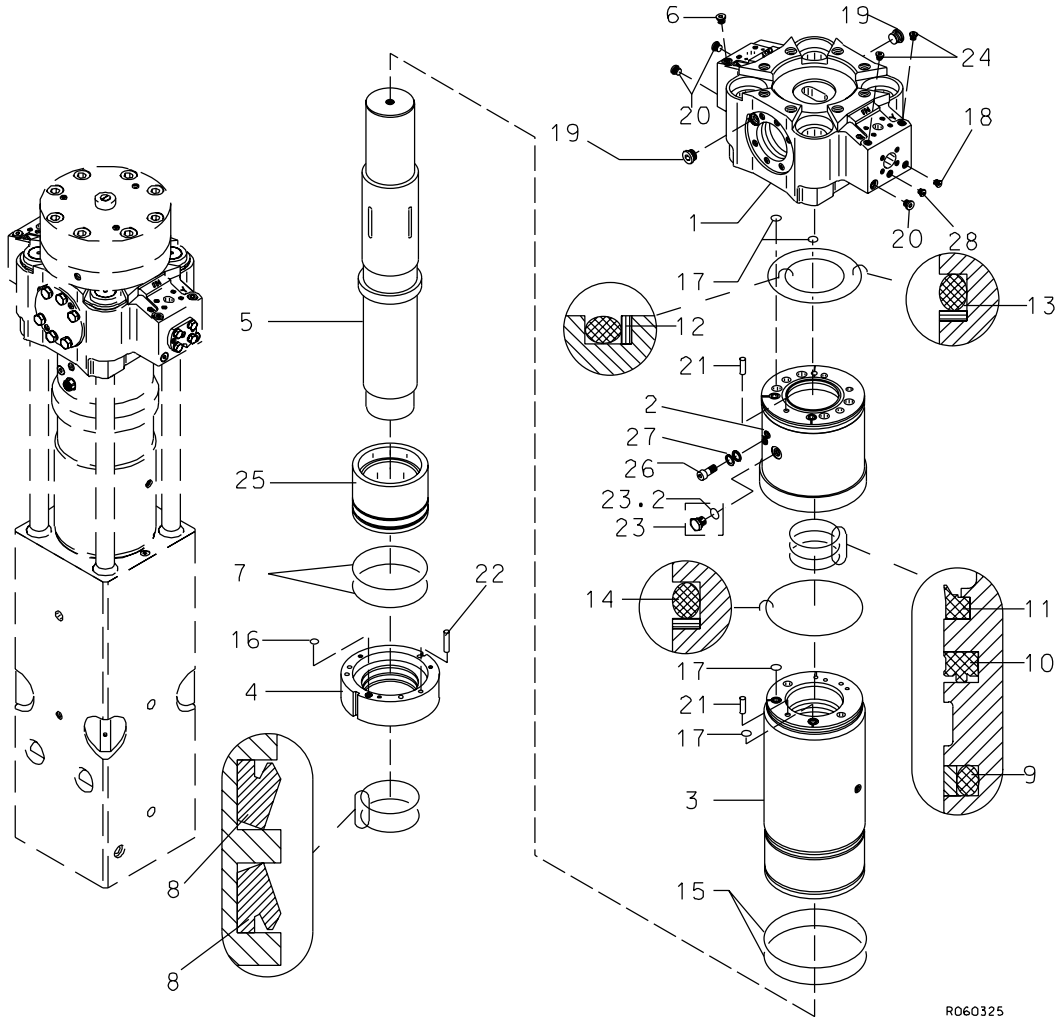

R060325

<b>Item</b>	<b>Description</b>	<b>Part no.</b>	<b>Specification</b>	<b>Note</b>	<b>Qty</b>
1	Valve body	105181			1
2	Seal carrier	105765			1
3	Cylinder	110374			1
4	Seal carrier	110177			1
5	Piston	153397			1
6	Breather	400562	G1/2		1
7	O-ring	90036	D209	*	2
8	Seal	903066	D160	*	2
9	Seal	111871	D141	*	1
10	Seal	911023	D142	*	1
11	Wiper	90064	D142	*	1
12	Seal	400474	D160	*	1
13	Seal	110509	D300	*	1
14	Seal	400481	D280	*	1
15	O-ring	910015	D269	*	2
16	O-ring	90011	D14	*	1
17	O-ring	910018	D21	*	4
18	Flange plug	90403	G1/4		2
19	Flange plug	90410	G1		2
20	Flange plug	90424	G1/2		3
21	Parallel pin	90317	16m6x50 DIN 6325		2
22	Parallel pin	904017	16m6x70 DIN 6325		1
23	Breather (incl. part 23.2)	101700			1
23.2	O-ring	901173	D27	*	1
24	Flange plug	90444	G3/8		2
25	Bearing bushing	103003			1
26	Hex. socket screw	91041	M12x60-8.8 DIN 912		1
27	Lock washer	91012	M12 NORD-LOCK		1
28	Plug	41658	G1/4		1
	*) Are included in seal set				

11. FRONT HEAD G 110

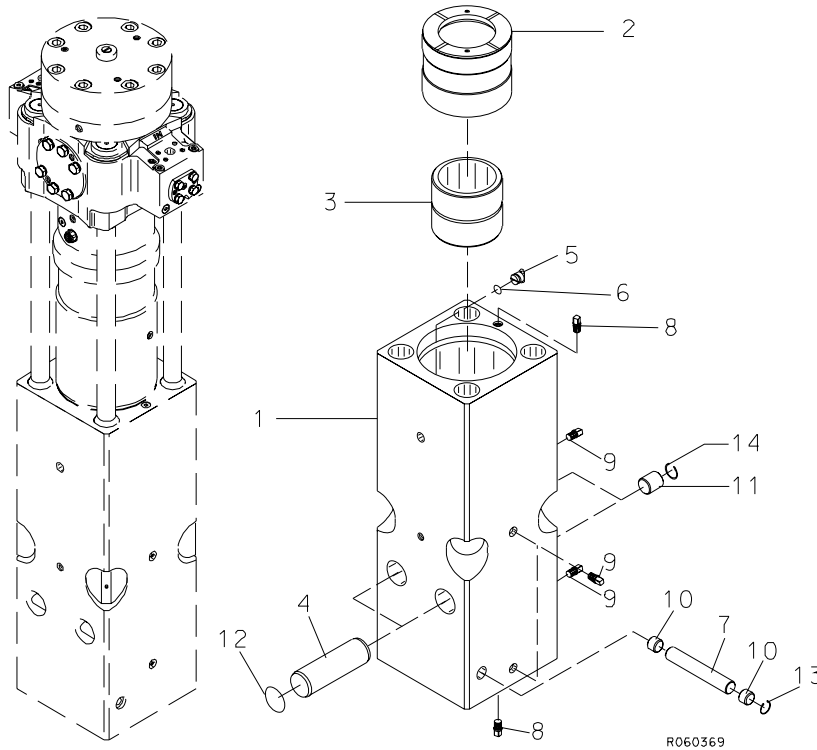

Item	Description	Part no.	Specification	Note	Qty
1	Front head (incl. parts 8-9)	105205			1
2	Thrust ring	105604			1
3	Upper tool bushing	105697			1
4	Tool retaining pin	105723	D85		2
5	Wedge	40110			1
6	O-ring	90000	D24	*	1
7	Retaining pin	400469			1
8	Plug	111404	G1/2		2
9	Plug	111399	G1/4		4
10	Plug	104235			2
11	Plug	104236			2
12	O-ring	90043	D84	*	2
13	Spring ring	902262	B40 DIN 7993		1
14	Spring ring	902807	B50 DIN 7993		2
	*) Are included in seal set				

12. LOWER TOOL BUSHING G 110

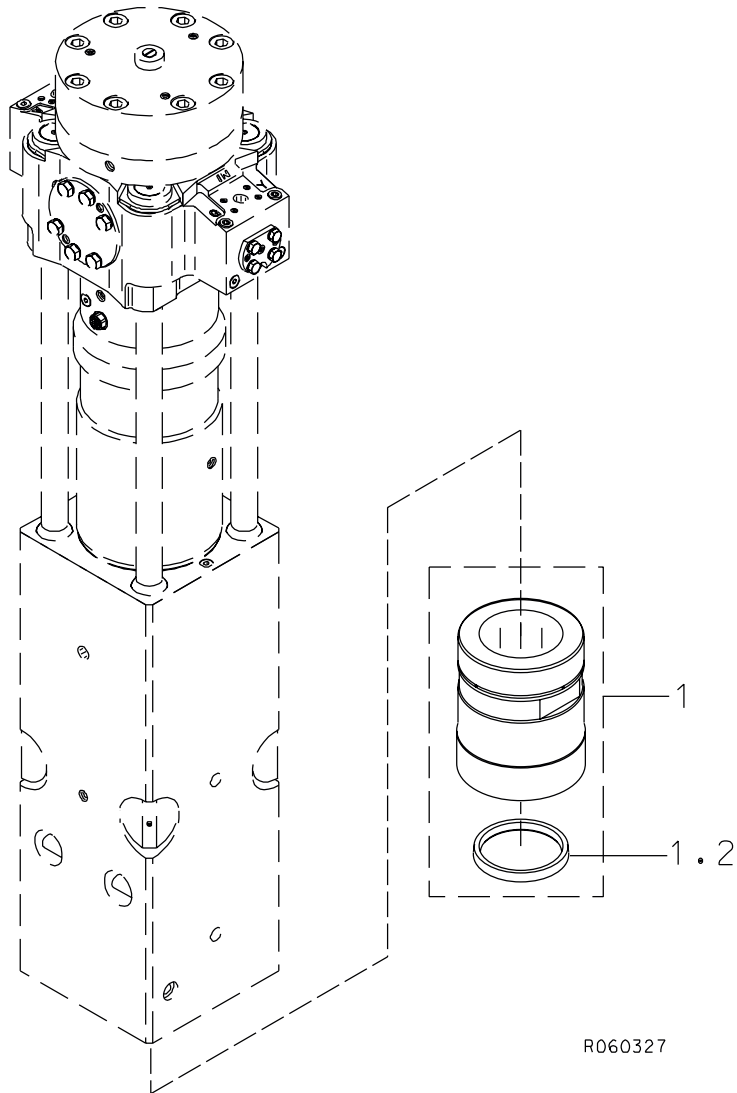

R060327

Item	Description	Part no.	Specification	Note	Qty
1	Lower tool bushing (incl. part 1.2)	105427			1
1.2	Seal	105426	D174		1

**13. SEAL SET G 110**

---

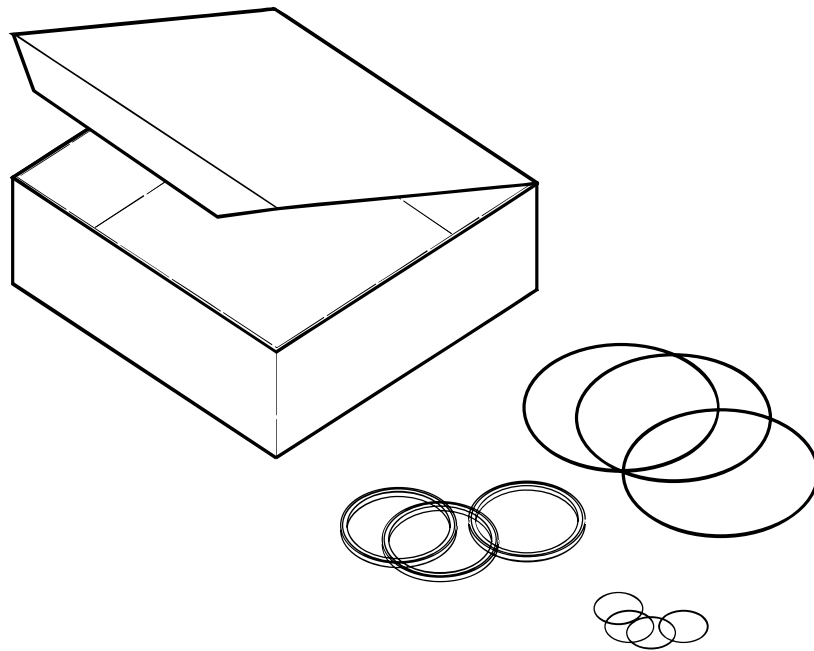

R060012

<b>Item</b>	<b>Description</b>	<b>Part no.</b>	<b>Specification</b>	<b>Note</b>	<b>Qty</b>
Kit	Seal set (incl. parts 1-27)	106653			1
1	Seal	40536	D145		1
2	Usit-ring	90056	D9		1
3	O-ring	90030	D75		1
4	Seal	41374	D55		1
5	O-ring	90007	D44		1
6	O-ring	94091	D39		1
7	O-ring	901186	D10		1
8	Usit-ring	901187	D18		1
10	O-ring	90000	D24		1
11	O-ring	90036	D209		2
12	Seal	903066	D160		2
13	Seal	111871	D141		1
14	Seal	911023	D142		1
15	Wiper	90064	D142		1
16	Seal	400474	D160		1
17	Seal	110509	D300		1
18	Seal	400481	D280		1
19	O-ring	910015	D269		2
20	O-ring	90011	D14		1
21	O-ring	910018	D21		4
22	O-ring	90032	D120		2
23	Seal	902644			6
24	O-ring	901173	D27		1
25	O-ring	90043	D84		2
26	O-ring	901942	D16		4
27	O-ring	910006	D23		1







**Sandvik Tamrock Corp., Breakers Lahti**  
**Taivalkatu 8, P.O. Box 165, FIN-15101 Lahti, Finland**  
**Phone Int. +358 205 44 161, Telefax Int. +358 205 44 160**  
**[www.rammer.com](http://www.rammer.com)**