

OPERATION AND MAINTENANCE
OMRB42NENG.903

PULVERIZER
RAMMER RB 42 N

OPERATION..... 3

1. Foreword	4
Preface	4
This manual	4
Important safety information	5
Warranty.....	5
Spare part orders.....	6
2. Machine numbers	7
Model and serial number	7
3. Product introduction.....	8
Overview.....	8
Removal from package	8
Lifting instructions	8
Main parts	9
4. Safety	10
General safety	10
Safety instructions.....	10
5. Operation	15
Operating instructions.....	15
Daily operation.....	17
Mounting and dismantling the equipment	22
Movement.....	23
Special conditions of use	23
Storage	24

LUBRICATION **25**

1. Greasing	26
Recommended greases.....	26
Greasing points	26
2. Carrier hydraulic oil	28
Requirements for hydraulic oil	28
Oil cooler	30
Oil filter	30

MAINTENANCE **33**

1. Routine maintenance	34
Overview.....	34
Inspection and maintenance by the operator	34
Inspection and maintenance by the dealer	35
Maintenance intervals in special applications.....	36
Other maintenance procedures	36
2. Turning and changing cutting blades ..	37
Wear limits, adjustments and torques for cutting blades	37
Removal of cutting blades.....	38
Installation of cutting blades.....	39
3. Hardfacing crusher jaw and teeth	40
Welding tools	40
Hardfacing crusher jaw and teeth	40
4. Replacing crusher teeth.....	42
Welding tools	42

Removal of tooth	42
Installation of tooth	42
5. Replacing crushing plate.....	44
Welding tools and tightening torque for crushing plate	44
Removal of crushing plate	44
Installation of crushing plate	45
6. Troubleshooting.....	46
Machine does not crush	46
Machine does not cut	46
Crusher jaw does not move	46
Excessive moving	47
Oil leakage	47

SPECIFICATIONS..... 49

1. Crusher specifications.....	50
Technical specifications RB 42 N.....	50
Main dimensions RB 42 N	50

OPERATION

1. FOREWORD

1.1 PREFACE

Congratulations on having purchased this product. A properly installed attachment should prove to be a productive machine requiring maintenance at only regular intervals.

1.2 THIS MANUAL

This manual is arranged to give you a good understanding of the equipment and its safe operation. It also contains maintenance information and technical specifications. Read this manual from front to back before installing, operating or maintaining the attachment for the first time.

In this manual, the units of measurement are metric. For example, weights are given in kilograms (kg). In some cases the other unit follows in parenthesis (). For example 28 litres (7.4 US gal).

The specifications and designs presented in this manual are subject to change without prior notice.

SYMBOLS USED IN THIS MANUAL

This symbol identifies important safety messages within this manual. Carefully read the message that follows. Failure to understand and obey this safety warning could result in injury to you or others, and could also cause damage to equipment. See illustration 1.

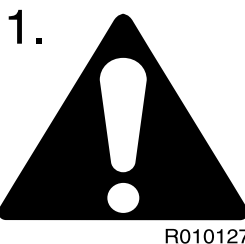

This symbol identifies prohibited action or hazardous location. Failure to understand and obey this safety warning could result in injury to you or others, and could also cause damage to equipment. See illustration 2.

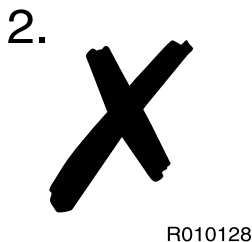

This symbol identifies correct and recommended action. See illustration 3.

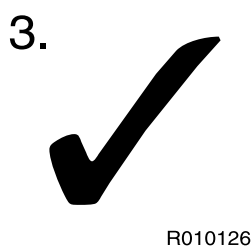

1.3 IMPORTANT SAFETY INFORMATION

Basic safety precautions are outlined in the "Safety" section of this manual and in the description of operations where hazards exist. These warnings are identified by the warning symbol.

To use the attachment correctly, you must also be a competent operator of the carrier machine. Do not use or install it if you can not use the carrier machine. The attachment is a powerful tool. Used without proper care, it can cause damage.

Do not rush when you are learning to use the product. Take your time and most importantly, take it safely. Do not guess. If there is anything you do not understand, ask your local dealer. He will be pleased to advise you.

Improper operation, lubrication or maintenance of this machine can be dangerous and could result in injury.

Do not operate this machine until you read and understand the instructions in this manual.

Do not perform any lubrication and maintenance on this machine until you read and understand the instructions in this manual.

1.4 WARRANTY

The customer is provided with a separate warranty sheet, where the export warranty terms are explained. Check always that this warranty sheet is provided with the attachment. If not, contact your local dealer immediately.

WARRANTY REGISTRATION CARD

A warranty registration card is filled out after the installation inspection by the dealer and a copy of it is sent to the manufacturer. This card is very important because no warranty claims are handled without it. Make sure that you get a copy of it after the installation inspection and that it is correctly filled out.

INSTALLATION INSPECTION

An installation inspection must be carried out after the product has been installed on the carrier. In the installation inspection certain specifications (operating pressure, oil flow, etc.) are checked so that they are within given limits.

1.5 SPARE PART ORDERS

When you need spare parts or some information concerning maintenance to your machinery, please contact your local dealer. Quick deliveries are ensured by exact orders.

Required information:

1. Name of customer, contact person
2. Order number (when available)
3. Delivery address
4. Mode of delivery (air mail, etc.)
5. Required delivery date
6. Invoicing address
7. Model and serial number of product
8. Name, number and required amount of spare parts

2. MACHINE NUMBERS

2.1 MODEL AND SERIAL NUMBER

The equipment serial number is stamped on the equipment body. The model and serial number are also located on the CE marking. Check that the model corresponds to the one given on the cover of this manual.

It is important to make correct reference to the serial number of the attachment when making repairs or ordering spare parts. Identification of the serial number is the only proper means of maintaining and identifying parts for a specific product.

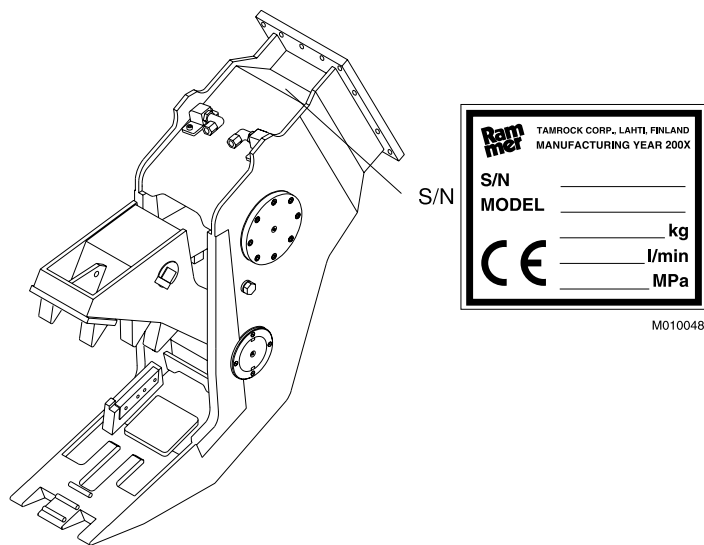

3. PRODUCT INTRODUCTION

3.1 OVERVIEW

The product is a hydraulically operated crusher. It can be used on any carrier which meets the necessary hydraulic and mechanical installation requirements.

3.2 REMOVAL FROM PACKAGE

Remove all the steel belts from the package. Open the package and remove all plastics covering the product. Recycle all package materials (steel, plastic, wood) properly.

Check that the product is in good condition and that there is no visible damage. Check that all ordered parts and accessories have been enclosed with the product. Some options may be provided by your local dealer like installation kits; including hoses and mounting bracket.

3.3 LIFTING INSTRUCTIONS

Use a hoist when lifting components which weigh 23 kg (50 lb) or more, to avoid back injury. Make sure all chains, hooks, slings, etc., are in good condition and are in the correct capacity. Be sure hooks are positioned correctly. Lifting eye is not to be side loaded during a lifting operation.

Lifting devices must safely carry the working weight of the product. See “Crusher specifications” on page 50. Place chain or sling, as shown by the illustration, to lift the product.

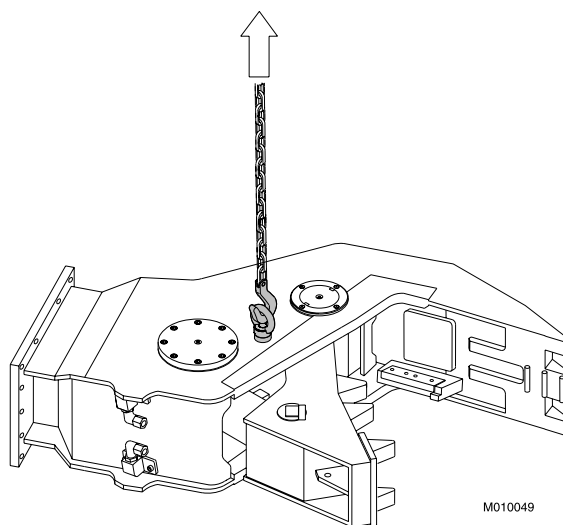

Note: The lifting eye must always be removed from the crusher and replaced with a blanking screw before starting to operate the crusher.

3.4 MAIN PARTS

The main parts of the pulverizer are shown below.

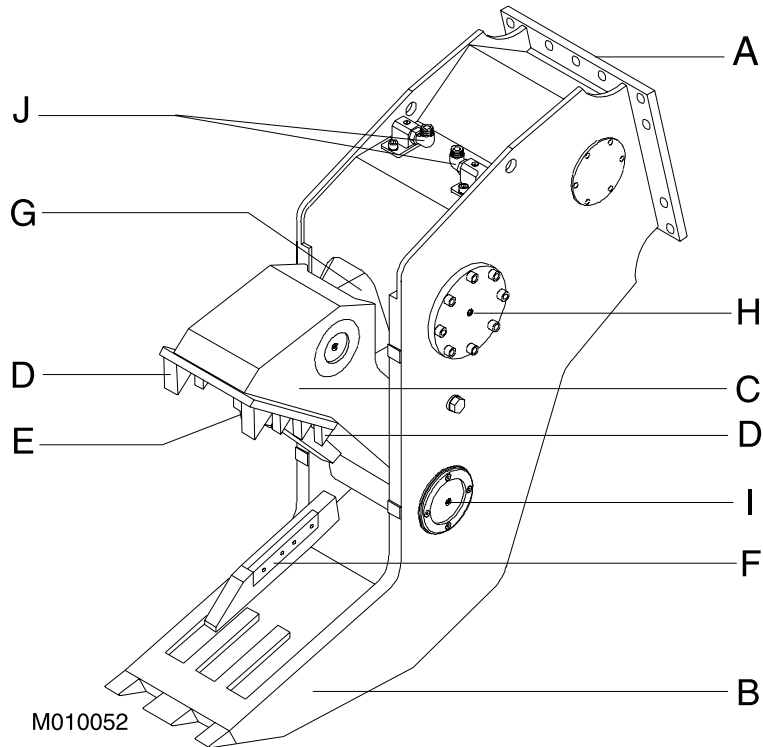

- A. Mounting bracket
- B. Fixed jaw
- C. Moving jaw
- D. Crushing tooth
- E. Breaking tooth
- F. Cutting blades
- G. Cylinder
- H. Trunnion bearing
- I. Pivot pin
- J. Hose connections

4. SAFETY

4.1 GENERAL SAFETY

All mechanical equipment can be hazardous if operated without due care or correct maintenance. Most accidents involving machine operation and maintenance are caused by failure to observe basic safety rules or precautions. An accident can often be avoided by recognizing potentially hazardous situations before an accident occurs.

Because it is impossible to anticipate every possible circumstance that might involve a potential hazard, the warnings in this guide and on the machine are not all inclusive. If a procedure, tool, working method or operating technique not specifically recommended by manufacturer is used, you must satisfy yourself that it is safe for you and others. You should also ensure that the product will not be damaged or made unsafe by the method of operation or maintenance procedures you choose.

Safety is not just a matter of responding to the warnings. All the time you are working with your attachment you must pay attention to what hazards there might be and how to avoid them. Do not work with the product until you are sure that you control it. Do not start any job until you are sure that you and those around you will be safe.



Warning! Read the following warning messages carefully. They tell you of different hazards and how to avoid them. If proper precautions are not taken you or others could be seriously injured.

4.2 SAFETY INSTRUCTIONS

MANUALS

Study this manual before installing, operating or maintaining the product. If there is anything you don't understand, ask your employer or your local dealer to explain it. Keep this manual clean and in good condition.

Study also the operating and maintenance manual of your carrier before operating the attachment.

CARE AND ALERTNESS

All the time you are working with the product, take care and stay alert. Always be careful. Always be alert for hazards. The possibility of a serious or even fatal accident is increased when you are intoxicated.

CLOTHING

You can be injured if you do not wear proper clothing. Loose clothing can get caught in the machinery. Wear protective clothing to suit the job.

Examples are: a safety helmet, safety shoes, safety glasses, well-fitting overalls, ear-protectors and industrial gloves. Keep cuffs fastened. Do not wear a necktie or scarf. Keep long hair restrained.

PRACTICE

You and others can be killed or injured if you do unfamiliar operations without practising them first. Practice away from the job site, in a clear area.

Keep other people away. Do not perform new operations until you are sure you can do them safely.

REGULATIONS AND LAWS

Obey all laws, work site and local regulations which affect you and your equipment.

COMMUNICATIONS

Bad communications can cause accidents. Keep people around you informed of what you will be doing. If you will be working with other people make sure they understand any hand signals you will be using.

Work sites can be noisy. Do not rely on spoken commands.

WORK SITE

Work sites can be hazardous. Inspect the site before working on it.

Check for potholes, weak ground, hidden rocks, etc. Check for utilities (electric cables, gas and water pipes, etc.). Mark the positions of cables and pipes.

Poor visibility can cause accidents and damage. Make sure that visibility and lighting of the working area are adequate.

BANKS AND TRENCHES

Banked material and trenches can collapse. Do not work too close to banks and trenches where there is a danger of collapse.

SAFETY BARRIERS

Unguarded equipment in public places can be dangerous. Place barriers around the machine to keep people away.

FLYING DEMOLITION DEBRIS

Protect yourself and your surroundings from flying debris. Do not operate the product or carrier with people around it.

Keep the cabin windows and doors closed during operation. Window bars are recommended to protect the windows from flying debris.

COLLAPSING CONCRETE FRAMES

Protect yourself and your surroundings from collapsing concrete frames. Do not operate the product or carrier with people around it.

EQUIPMENT LIMITS

Operating the product beyond its design limits can cause damage. It can also be dangerous. See “Crusher specifications” on page 50.

Do not try to upgrade the product's performance by unapproved modifications.

HYDRAULIC FLUID

Fine jets of hydraulic fluid at high pressure can penetrate the skin. Do not use your fingers to check for hydraulic fluid leaks. Do not put your face close to suspected leaks. Hold a piece of cardboard close to suspected leaks and then inspect the cardboard for signs of hydraulic fluid. If hydraulic fluid penetrates your skin seek medical help immediately.

Hot hydraulic fluid can cause severe injuries.

HYDRAULIC HOSES AND FITTINGS

Ensure all hydraulic components will withstand maximum pressure and mechanical stresses caused by operation of the attachment. Consult your local dealer for instructions.

FIRE HAZARD

Most hydraulic fluids are flammable and might ignite when contacting hot surface. Avoid spilling hydraulic fluid to hot surfaces.

Working with the product on certain materials can cause sparks and hot splinters to get loose. These can ignite flammable materials around working area.

Ensure that adequate extinguisher is available.

HYDRAULIC PRESSURE

Hydraulic fluid at system pressure can injure you. Before disconnecting or connecting hydraulic hoses, stop the carrier engine, operate the controls to release pressure trapped in the hoses. During the operation, keep people away from the hydraulic hoses.

There might be pressurized oil trapped inside the product even if it is disconnected from the carrier. Be aware of possible unexpected jaw movements while greasing or removing and installing cutting blades. See “Turning and changing cutting blades” on page 37.

LIFTING EQUIPMENT

You can be injured if you use faulty lifting equipment. Make sure that lifting equipment is in good condition. Make sure that the lifting tackle complies with all local regulations and is suitable for the job. Make sure that the lifting equipment is strong enough for the job and you know how to use it.

Do not use this product or any of its parts for lifting. See “Lifting instructions” on page 8. Contact your carrier dealer to find out how to lift with your carrier.

SPARE PARTS

Use only genuine spare parts. Use only genuine cutting blades with crushers. The use of other spare part or cutting blade brands may damage the product.

EQUIPMENT CONDITION

Defective equipment can injure you or others. Do not operate equipment which is defective or has missing parts.

Make sure the maintenance procedures in this manual are completed before using the product.

REPAIRS AND MAINTENANCE

Do not try to do repairs or any other maintenance work you do not understand.

MODIFICATIONS AND WELDING

Non-approved modifications can cause injury and damage. Contact your local dealer for advice before modifying the product. Before welding on the product while it is installed on the carrier, consult your carrier dealer for precautions in welding.

METAL SPLINTERS

You can be injured by flying splinters when driving metal pins in and out. Use soft-faced hammer or drifts to remove and fit metal pins, such as pivot pins. Always wear safety glasses.

5. OPERATION

5.1 OPERATING INSTRUCTIONS

RECOMMENDED USE

The pulverizer is designed for use in demolishing work to pulverize demolition material. It can be used in recycling plants for separating the concrete from the reinforcement bars or for removing and regrinding road surfaces. Your local dealer will gladly give you more information.

OPERATING CONDITIONS

Principles of installation

Almost all carriers meeting mechanical and hydraulic requirements can be used to operate attachments. See “Crusher specifications” on page 50. The product is installed on the carrier much in the same manner as installing a bucket or other attachments. A flange mounted attachment requires also a separate mounting bracket.

The attachment is connected to a carrier's hydraulic circuit with an installation kit. If the carrier is already fitted with an installation kit, the installation requires only suitable hoses and fittings. For crusher installation, secondary relief valves in bucket cylinder circuit and in carrier auxiliary circuit are needed. If the carrier does not have suitable kit to run attachments, one must be built. This may require more complex installation including new piping and additional valves such as flow control valve or pressure relief valve.

Suitable kits can be ordered from the manufacturer or local dealers, from carrier manufacturers and their dealers or from third party suppliers.

Hydraulic oil

In general the hydraulic oil originally intended for the carrier can be used with this product. See “Requirements for hydraulic oil” on page 28.

Operating temperature

The operating temperature is -20 °C to +80 °C (-4 °F to +176 °F). If you must work in a temperature lower than -20 °C (-4 °F), the equipment has to be preheated before any operations can begin. Start the operation with low hydraulic flow.

Note: The temperature of the hydraulic oil must be monitored. Ensure that oil grade and monitored oil temperature together guarantee correct oil viscosity. See “Oil specifications” on page 29.

PRINCIPLES OF OPERATION

The operation of the equipment is based on a static force produced by the hydraulic cylinder of the equipment. To increase the product's working life, pay particular attention to correct working methods.

Crushing is performed in the front of the crusher jaws. Avoid using cutting blades for crushing.

Cutting is performed with cutting blades at the rear of the crushing mouth. The cutting blades can be reversed.

CRUSHER JAWS, TEETH AND CUTTING BLADES

Crusher jaws

Crusher jaws are operated by the hydraulic cylinder of the crusher. One jaw is fixed and the other, equipped with breaking tooth, is moving. Crushing is performed using the crushing teeth of the jaws.

Breaking tooth

The long-lasting convex shaped breaking tooth is made of special steel.

Crushing plate

The teeth of the crushing plate are made of special steel. The teeth are welded directly onto the plate. The crushing plate is removable, so that the teeth can be serviced separately.

Cutting blades

The cutting blades are fastened with screws and can be turned, so that all four cutting edges can be used or replaced with new cutting blades. See "Turning and changing cutting blades" on page 37.

The stopper nipple at the outer end of the blade prevents steel beams from slipping from cutting blades.

5.2 DAILY OPERATION



Warning! Protect yourself and your surroundings from flying debris and collapsing concrete frames. Do not operate the pulverizer or carrier with people around it.



The pulverizer as a standard assembly, must not be used under water. Contact your local dealer for more information on underwater use.

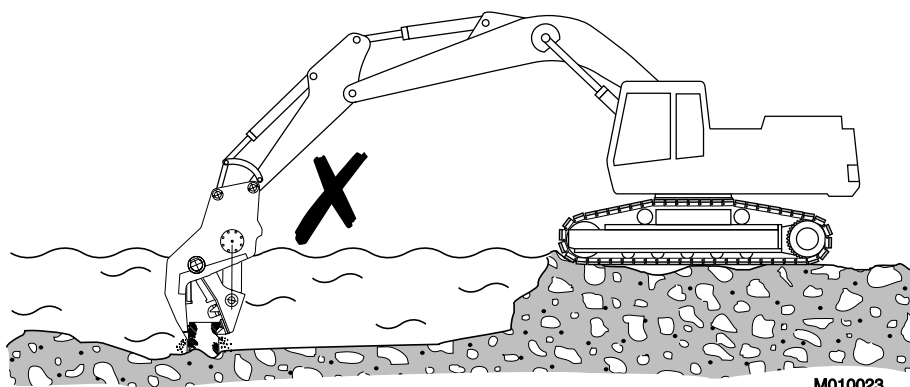

M010023

1. Prepare the carrier for normal excavation work. Move the carrier to the required position. Set the drive to neutral.
2. Set the engine speed to the recommended engine RPM.
3. Carefully operate the carrier controls to place the pulverizer and boom into the crushing position. Quick and careless boom movements could result in damage to the pulverizer.

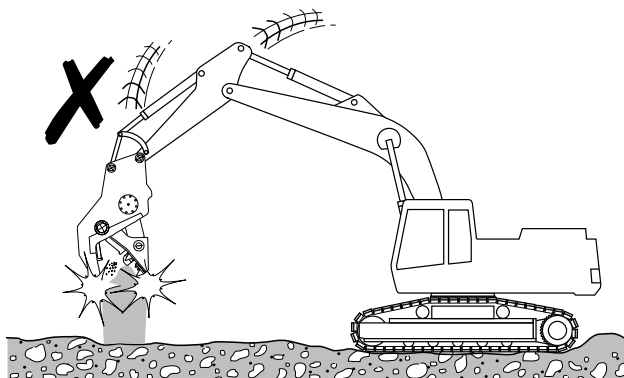

M010024

4. Open the crusher jaws, position the object on the fixed jaw side by operating excavator cylinders and close the jaws to crush. The best crushing result is obtained by using the whole tooth area of the crusher jaws. Avoid crushing concrete with cutting blades.

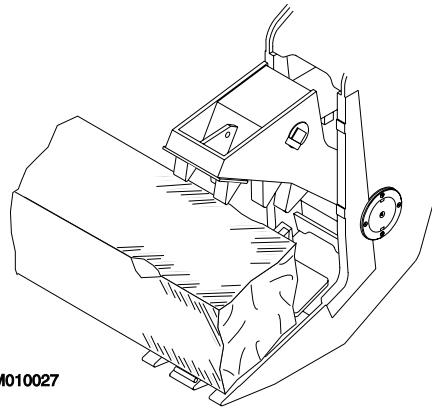

5. When crushing very large concrete blocks, start crushing from the outer edges of the concrete.

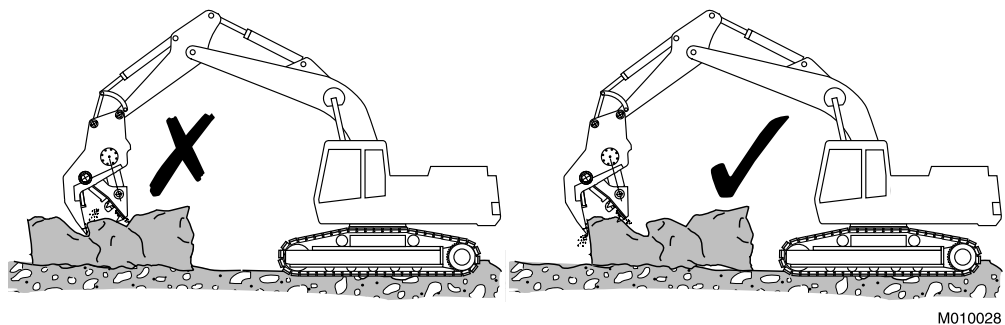

6. A safety screen is recommended to protect the operator from flying debris. Keep the cabin windows and doors closed during operation.

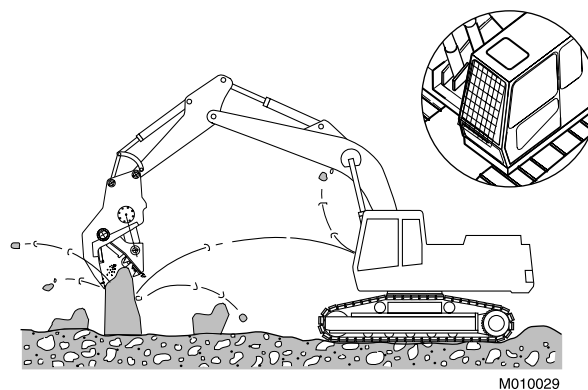

7. To cut rebars or similar objects with the pulverizer, open the jaws, operate the excavator cylinder to position object on the cutting blade on the fixed jaw side and close the jaws to cut. For the best possible cutting performance and to avoid damaging the pulverizer, only use cutting blades for cutting.

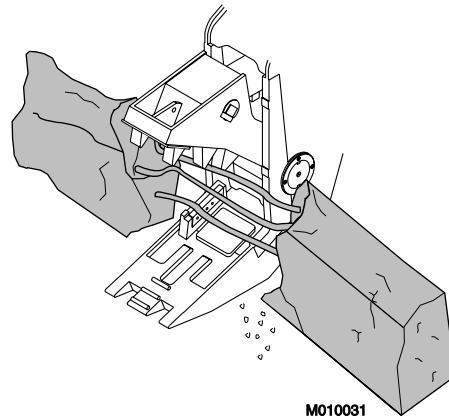

8. The pulverizer is intended for pulverizing, do not use the pulverizer as a lever or to strike, hit or ram objects. Do not use the side of the pulverizer to move concrete or object.

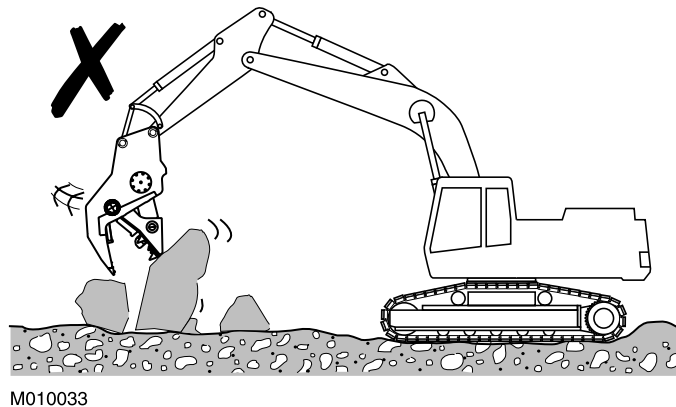

9. Do not use the pulverizer for lifting. Lifting eyes on pulverizer are for storage and maintenance purposes only.

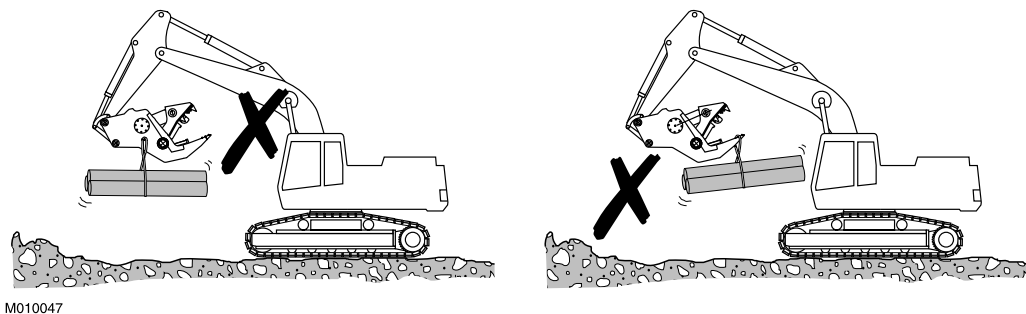

10. Do not use the pulverizer while applying down pressure with the excavator.

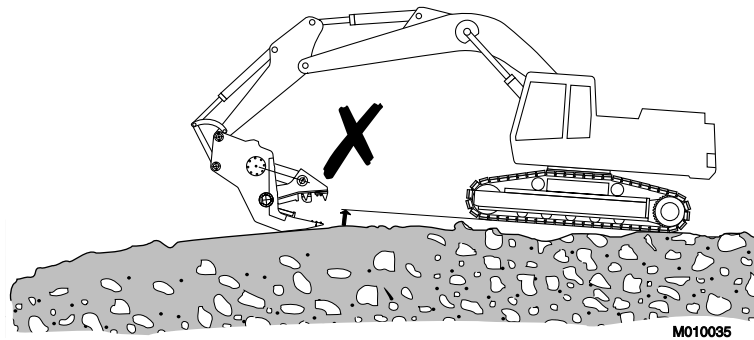

11. When operating the pulverizer, make sure that it does not make contact with the carrier boom or hydraulic lines.

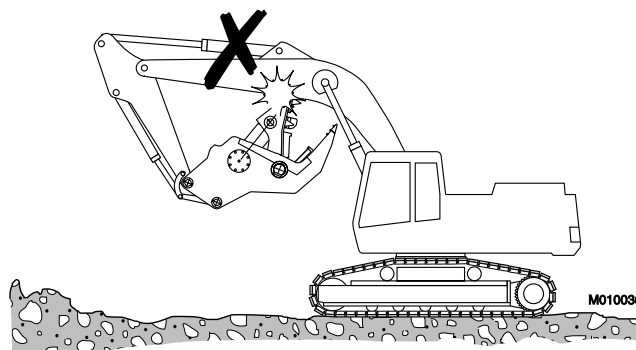

12. Do not operate the pulverizer with the carrier's boom stick or bucket cylinders at the end of their stroke (either fully extended or retracted). Damage to the carrier may result.

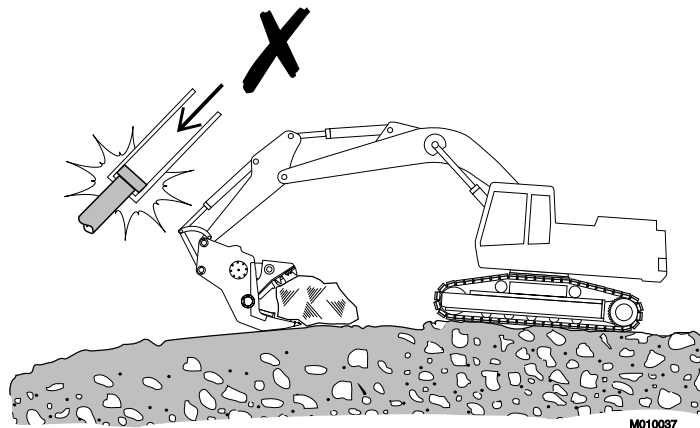

13. When the crusher jaws are closed, the cylinder rod is exposed. The operator must avoid hitting the rod or shield plate with concrete or iron bars. Damage to the cylinder rod or shield plate may cause rod seal breakage and oil leaks.

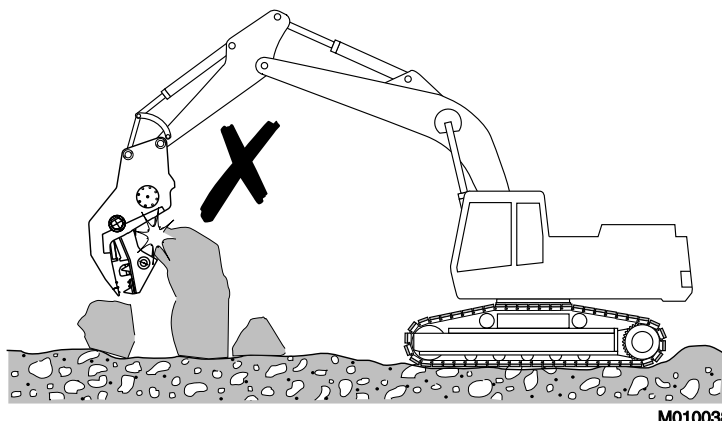

14. Always remove demolition debris from the pulverizer. Getting steel frame or rebar between crusher jaws and cylinder rod clevis can cause damage to the cylinder rod or crusher jaws. Getting steel bars in the clearance between the crushing arm and the base of fixed jaw can cause damage to main shaft.

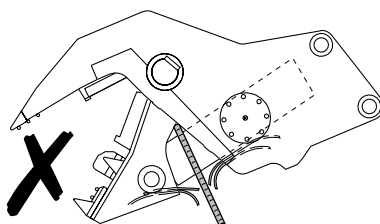

M010039

15. The bearings must be well greased during operation. Regular inspections during operation are recommended. If no grease is visible, bearings require more frequent greasing. Bearings covered with excessive grease require less frequent greasing.

5.3 MOUNTING AND DISMOUNTING THE EQUIPMENT

REMOVAL FROM CARRIER



Warning! The equipment must be secured from rolling over when disconnecting from the carrier. Only use skilled operator to position carrier for the removal!

Warning! Hydraulic pressure inside the equipment must always be released before opening hose connections!

Warning! Hot hydraulic fluid can cause severe injuries!

1. Position attachment horizontally on the floor.
2. Stop the carrier engine. Operate boom and attachment controls to release pressure trapped inside hoses.
3. Close attachment shut-off valve. If quick couplers are used, disconnection automatically closes attachment lines. If the line includes ball valves, please make sure that they are closed.
4. Disconnect hoses. Plug the hoses.
5. Remove bucket pins and other parts.

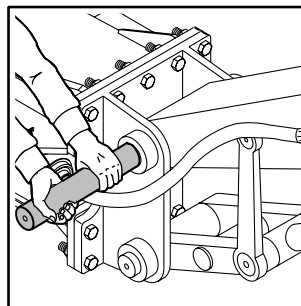
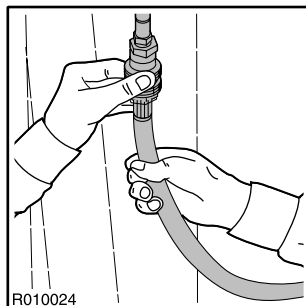

6. The carrier can be moved aside.

INSTALLATION



Warning! The residual air in the hoses must always be removed before operation!

1. Install equipment in the same manner as mounting a bucket. Install bucket pins.
2. Connect hoses.

3. Open the ball valves.
4. Remove air from the hoses by carefully operating the crusher cylinder. Open and close empty jaws several times.

5.4 MOVEMENT

The transportation and parking positions are shown below. When moving the carrier, ensure that the crusher is not too close to the carrier.

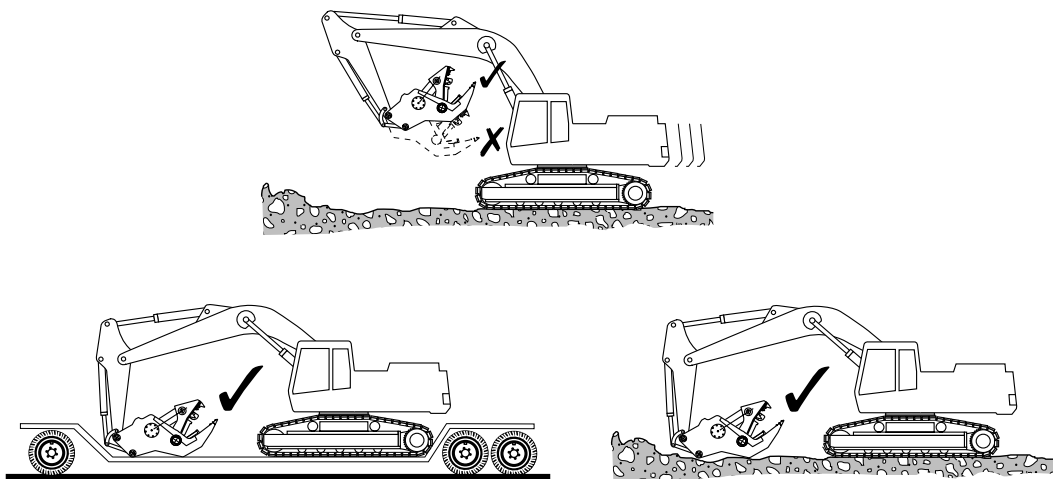

M010044

5.5 SPECIAL CONDITIONS OF USE

The equipment may require modifications, special operating techniques, increased maintenance or special wear items if it is used in conditions that differ from normal breaking or demolition work. Special conditions of use are:

- Underwater operations
- Operations in extremely low or high temperatures
- Use of special hydraulic fluids
- Operations with special carrier
- Other special conditions

In case of special conditions of use, please consult your local dealer for instructions.



The crusher as a standard assembly, must not be used under water. Contact your local dealer for more information on underwater use.

5.6 STORAGE

LONG TERM STORAGE

Observe the following points when the product is stored. In this way the vital parts of the attachment are protected from rust and the machine is ready to be used whenever necessary.

1. The storage area must be dry.
2. To avoid damaging the cylinder rod, operate the cylinder to the shortest position by leaving the crusher jaws open.
3. Insert blocks under the crusher to keep it off the ground. If the machine is stored outside, cover it to prevent rusting.

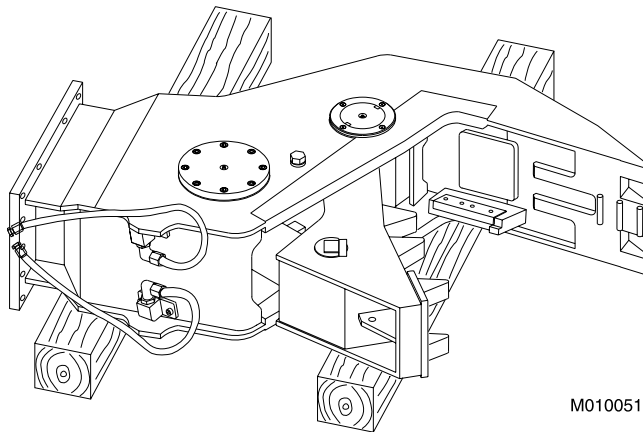

4. Apply grease to all crusher parts. Protect mounting bracket, pin holes, cutting blades and pivot ends with an anticorrosive agent.
5. Connections must be sealed with clean plugs to prevent oil leakage and dirt from getting into couplings.
6. Make sure the product can not fall.

LUBRICATION

1. GREASING

1.1 RECOMMENDED GREASES

Item	Recommended greases	Greasing interval
Crusher parts	ESSO Beacon EP2	every 8 hours
	SHELL Retinax EP2	
	FUCHS Lubritech, Lagermeister EP 2	
	MOBIL Mobilux EP 2	

1.2 GREASING POINTS

The greasing points of the crusher have been marked with the following sticker.



R020002

The greasing points of the crusher are shown below.

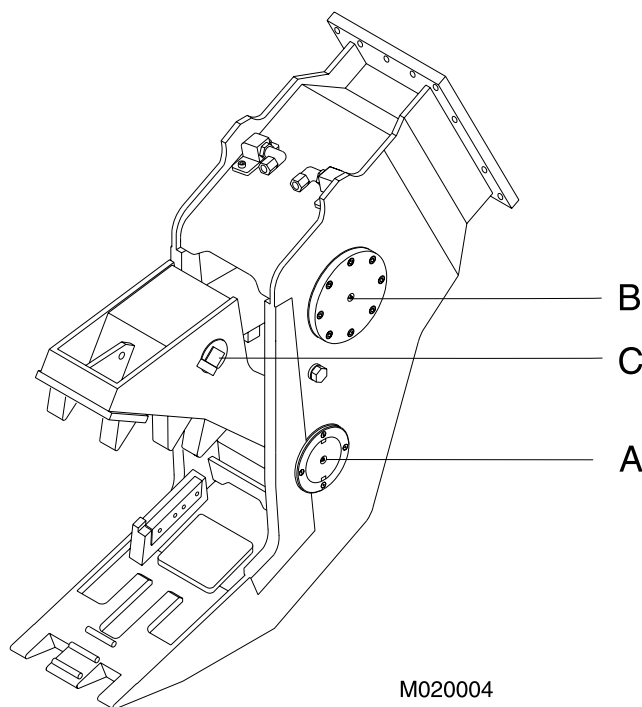

- A. Main shaft
- B. Trunnion
- C. Rod pin

CRUSHER PARTS

1. Always grease before operation and after every 8 hours of operation.
 2. Adapt greasing interval and amount of grease to working conditions.
- Insufficient greasing or improper grease may cause abnormal wear of parts.

2. CARRIER HYDRAULIC OIL

2.1 REQUIREMENTS FOR HYDRAULIC OIL

GENERAL REQUIREMENTS

In general the hydraulic oil originally intended for the carrier can be used with this product. However, since working with the product heats the oil more than the usual excavation work, the temperature of the oil must be monitored.

If the temperature of the hydraulic oil exceeds +80 °C (+176 °F), an auxiliary oil cooler is needed. The oil viscosity must be between 1000-20 cSt while the attachment is being used.

When the product is used continuously, the temperature of the hydraulic oil normalizes at a certain level depending on conditions and on the carrier. The temperature in the tank must not exceed the maximum allowed.

The attachment must not be started if the ambient temperature is below freezing and the oil is very thick. The machine must be moved to bring the oil temperature above 0 °C (+32 °F) before working can start (viscosity 1000 cSt or 131 °E).

OIL SPECIFICATIONS

Table below shows hydraulic oils recommended for equipment use. The most suitable oil is selected in such a way that the temperature of the hydraulic oil in continuous use is in the ideal area on the chart and the hydraulic system is used to best advantage.

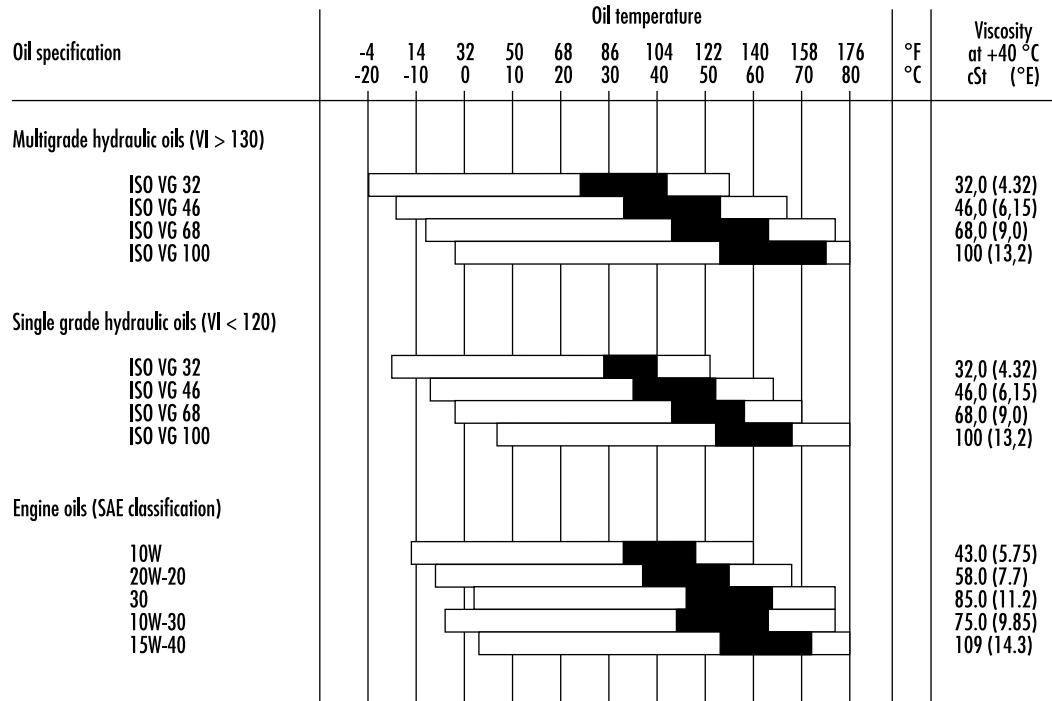

VI = Viscosity index
 □ Permitted oil temperature
 ■ Recommended oil temperature

R020004

Problems due to incorrect hydraulic oil viscosity in the equipment:

Oil too thick

- Difficult start up
- Stiff operation
- Danger of cavitation
- Sticky valves
- Filter bypass opens, impurities in the oil are not removed

Oil too thin

- Efficiency losses (internal leaks)
- Damage to gaskets and seals, leaks
- Accelerated wearing of parts, because of decreased lubrication efficiency
- Danger of cavitation

Note: We strongly recommend the use of different hydraulic oils in the summer and in the winter if there is an average temperature difference of more than 35 °C (63 °F). The correct hydraulic oil viscosity is thus ensured.

SPECIAL OILS

In some cases special oils (e.g. biological oils and non-inflammable oils) can be used with the crushers. Observe the following aspects when considering the use of special oils:

- The viscosity range in the special oil must be in the given range (20-1000 cSt)
- The lubrication properties must be sufficient
- The corrosion resistance properties must be good enough

Note: Although a special oil could be used in the carrier, always check its suitability with the attachment. Contact the oil manufacturer or your local dealer for more information about special oils.

2.2 OIL COOLER

The carrier hydraulic system must be able to maintain the temperature within an acceptable level during the crusher operation. This is for two reasons.

1. Seals, wipers, membranes and other parts manufactured from the corresponding materials can normally stand temperatures up to +80 °C (+176 °F).
2. The higher the temperature is, the less viscous the oil gets thus losing its capability to lubricate.

A standard carrier, with a proper crusher circuit, meets the requirements of the necessary cooling capacity. If the oil temperature tends to be too high during the crusher operation, the following things must be checked:

- The crusher circuit pressure relief valve should not be opened unnecessarily.
- The crusher circuit pressure drops must be reasonable, less than 20 bar in the hydraulic line.
- There should be no internal leakages in crusher or in carrier hydraulic pumps, valves, cylinders, motors, etc.

If all of the above mentioned things are in order, and the temperature of the hydraulic oil still tends to be too high, extra cooling capacity is needed. Consult the carrier manufacturer or dealer for details.

2.3 OIL FILTER

The purpose of the oil filter is to remove impurities from the hydraulic oil. Air and water are also impurities in oil. Not all impurities can be seen with the naked eye.

Impurities enter the hydraulic system:

- During hydraulic oil changes and refilling.
- When components are repaired or serviced.
- When the attachment is being installed on the carrier.
- Because of component wear.

Normally the existing main oil filters of the carrier are used as attachment circuit return line filters. Consult the carrier manufacturer or your local dealer concerning instructions for the filter change intervals.

In crusher work the carrier oil filter must fulfil the following specifications:

- The oil filter must allow maximum particle size of 25 microns (0.025 mm).
- The oil filter material must be man-made fibre cloth or very fine gauge metallic mesh to withstand pressure fluctuations.
- The oil filter must have a nominal flow capacity of at least twice the attachment's maximum flow.

In general, oil companies guarantee new oils to have a particle count of 40 microns maximum. Filter the oil when filling the tank.

The damage caused by hydraulic oil impurities in the carrier and attachment circuits:

Shortened working life of pumps and other components

- Rapid wear of parts.
- Cavitation.
- Wear of cylinder and gaskets.

Reduced attachment efficiency

- Accelerated wear of moving parts and seals.
- Oil leakages.

Shortened working life and reduced lubricating capability of oil

- Overheated oil.
- Deteriorated oil quality.
- Electro-chemical changes in hydraulic oil.

Malfunction of valves

- Binding spools.
- Rapid wear of parts.
- Blocking of small holes.

Note: Component damage is only a symptom. The trouble itself will not be cured by removing the symptom. After any component damage due to impurities in the oil, the entire hydraulic system has to be cleaned. Dismantle, clean and reassemble the crusher and change the hydraulic oil.

MAINTENANCE

1. ROUTINE MAINTENANCE

1.1 OVERVIEW

This product is a precision made hydraulic machine. Therefore great care and cleanliness should be taken when handling any of the hydraulic components. Dirt is the worst enemy in hydraulic systems.

Handle the parts carefully and remember to cover any cleaned and dried parts with clean lint-free cloth. Do not use anything other than purpose designed materials for cleaning hydraulic parts. Never use water, paint thinners or carbon tetrachloride.

Components, gaskets and seals in the hydraulic system should be oiled with clean hydraulic oil before assembly.

Remember to grease the crusher parts regularly according to the instructions in this manual. See “Greasing points” on page 26.

Close the crusher jaws during maintenance or inspection. If you must leave the jaws open, remember to block the jaws to prevent them from closing.

Prior to maintenance or inspection, operate all the control levers to their fully extended stroke. This will release pressure within the hydraulic piping and prevent unexpected movement of the jaw and loss of oil through the hydraulic lines.

1.2 INSPECTION AND MAINTENANCE BY THE OPERATOR

Note: The times given refer to the carrier hours while the attachment is installed.

EVERY EIGHT HOURS

Grease main shaft, trunnion and rod pin. See “Recommended greases” on page 26.

DAILY MAINTENANCE

1. Check the hydraulic hoses and hose connections. Tighten if necessary.
2. Check the cutting blades and their clearance. Tighten bolts or replace the cutting blades, if necessary. See “Turning and changing cutting blades” on page 37.
3. Check the crusher jaws and teeth for wear. Hardface or replace, if necessary. See “Hardfacing crusher jaw and teeth” on page 40. See “Replacing crusher teeth” on page 42.
4. Check the grease nipples.

WEEKLY MAINTENANCE

1. Check the main body for wear.
2. Check the pins and bushings for wear.
3. Check cylinder rod, seals and connection points for wear. Tighten if necessary.
4. Observe hydraulic oil temperature, all lines and connections.
5. Check that the crusher works smoothly by operating the jaws.
6. Tighten connections, if necessary.

1.3 INSPECTION AND MAINTENANCE BY THE DEALER

Note: The times given refer to the carrier hours while the attachment is installed.

INITIAL 50-H INSPECTION

It is recommended to have the first inspection done by your local dealer after 50 to 100 operating hours. Contact your local dealer for more information about the initial 50-hour inspection.

EVERY 600 HOURS OR ONCE A YEAR

This service is recommended to be done by your local dealer after 600 operating hours. Neglecting the yearly service can cause severe damage to the crusher.

Your local dealer will reseal the crusher and replace safety decals as needed. Contact your local dealer for more information about yearly servicing.

During this maintenance you should do the following tasks.

- Check all hydraulic connections.
- Check that the hydraulic hoses do not rub against anything in any boom/stick position.

1.4 MAINTENANCE INTERVALS IN SPECIAL APPLICATIONS

The service interval is considerably shorter with special applications such as underwater use. See “Special conditions of use” on page 23. In special applications, please consult your local dealer for the correct service intervals.



The crusher as a standard assembly, must not be used under water. Contact your local dealer for more information on underwater use.

1.5 OTHER MAINTENANCE PROCEDURES

WASHING THE ATTACHMENT

When working with attachment and removing it from the carrier, dirt (mud, rock powder, etc.) can become attached to it. Wash the outside of the product with a steam washer before sending it to the workshop. Dirt can cause difficulties in disassembly and assembly otherwise.

CAUTION! Plug the pressure and return line before washing the product or else dirt can enter into it and this may cause damage to the components.

2. TURNING AND CHANGING CUTTING BLADES

WEAR LIMITS, ADJUSTMENTS AND TORQUES FOR CUTTING BLADES

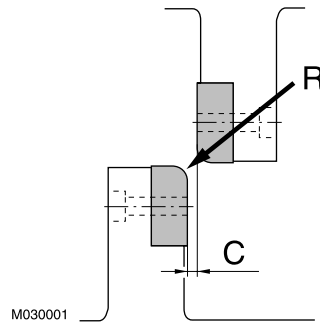

Item	Wear limit
Cutting blade edge (R)	5 mm (0.19 in)
Item	Adjustment
Cutting blade clearance (C)	0.5-1.0 mm (0.019-0.039 in)
Item	Tightening torque
Cutting blade	85 Nm (63 lbf ft)

REMOVAL OF CUTTING BLADES



Prior to maintenance or inspection, operate all the control levers to their fully extended stroke. This will release pressure within the hydraulic piping and prevent unexpected movement of the jaw and loss of oil through the hydraulic lines.



Support the crusher jaw to prevent it from closing unexpectedly during maintenance.

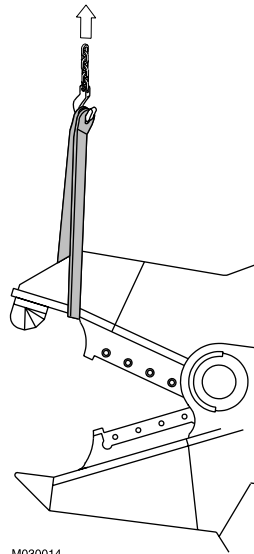

M030014

1. Position the attachment on level ground.
2. Support the crusher jaw.
3. Make sure the carrier's transmission is in neutral and the parking brake is engaged.
4. Stop the carrier engine.
5. Clean the cutting blades and the base.
6. Remove hex socket-head screws and lock washers.
7. Remove cutting blades and shim plates.

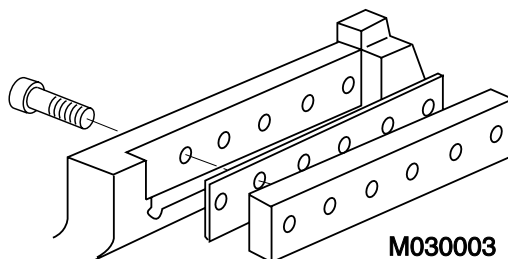

M030003

8. Finish the surfaces by grinding, flush all burrs from cutting blade and cutter base.

Note: If burrs remain on the surface the cutting blade will not have proper contact with the cutter base. This will cause breakage of the cutting blade.

INSTALLATION OF CUTTING BLADES

1. Reverse the cutting blade so that unused edge can be used or install a new cutting blade.
2. Set cutting blade on the base.
3. Fit cutting blade into cutter base with a couple of screws.
4. Use a plastic hammer to seat cutting blade into its place with proper contact.
5. Close crusher jaws and measure the clearance between cutting blades.
6. Adjust the clearance (C) between cutting blades according to specifications. If necessary add or remove shim plates.

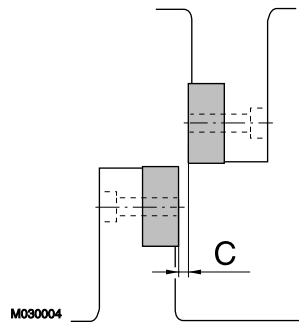

7. Install lock washers and hex socket-head screws.
8. Torque screws to the specified setting.

3. HARDFACING CRUSHER JAW AND TEETH

WELDING TOOLS

Item	Welding tool
Repair of parent	MIG-wire, DIN 8559: SG 2
	Welding rod, DIN 1913: E 51 53 B 10
Hardfacing	MIG-wire, DIN 8555: SG 6 - 60
	Welding rod, DIN 8555: E 6 - 55

HARDFACING CRUSHER JAW AND TEETH



Welding must occur in a workshop with proper welding tools. If you must weld the crusher when it is installed in carrier, consult your carrier dealer for precautions during welding.

Support the crusher jaw to prevent it from closing unexpectedly during maintenance.

1. Position the attachment on level ground.
2. Support the crusher jaw.
3. Carefully remove the worn part by carbon arc gouging or by gas cutting at the base. Note: Connect earth cable to the part to be repaired.
4. Repair parent by filling it with welding rod, and finish the surface by grinding.
5. Preheat hardfacing area to +100...+150 °C.

6. Perform hardfacing. The hardfacing area of the crusher is shown in the illustration below.

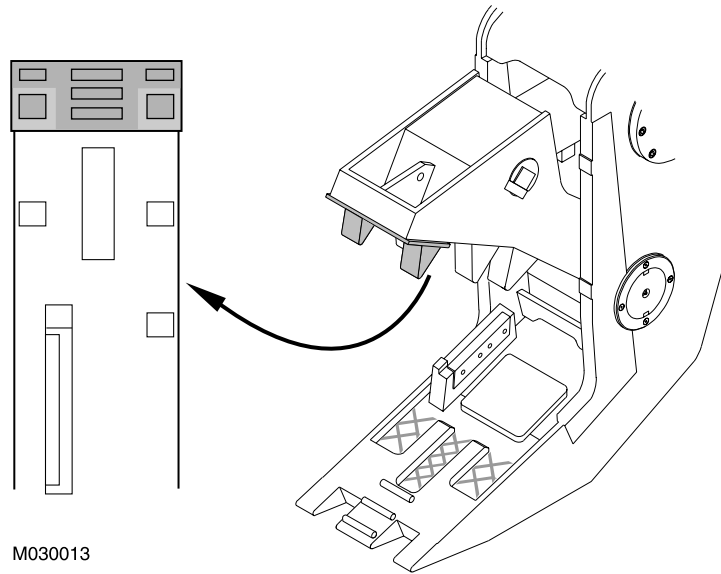

4. REPLACING CRUSHER TEETH

WELDING TOOLS

Item	Welding tool
Repair of parent, installation of tooth	MIG-wire, DIN 8559: SG 2
	Welding rod, DIN 1913: E 51 53 B 10
Hardfacing	MIG-wire, DIN 8555: SG 6 - 60
	Welding rod, DIN 8555: E 6 - 55

REMOVAL OF TOOTH



Welding must occur in a workshop with proper welding tools. If you must weld the crusher when it is installed in carrier, consult your carrier dealer for precautions during welding.

Support the crusher jaw to prevent it from closing unexpectedly during maintenance.

1. Position the attachment on level ground.
2. Support the crusher jaws.
3. Cut off the worn part by carbon arc gouging or by gas cutting at the base. Note: Connect earth cable to the part to be repaired.
4. Repair parent by filling it with welding rod, and finish the surface by grinding.
5. Make edge preparation on the body side.

INSTALLATION OF TOOTH

1. Tack the new part with welding rod. Note: Connect earth cable to the part to be repaired.
2. Remove the block from the crusher mouth.

3. Close the crusher jaws to make sure that the front tooth and the side tooth do not touch the fixed jaw.

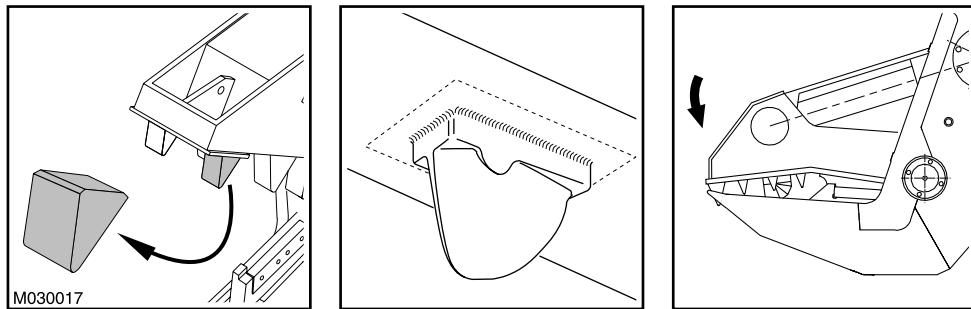

4. Preheat the jaw and the part to +100...+150 °C.
5. Perform welding.

5. REPLACING CRUSHING PLATE

WELDING TOOLS AND TIGHTENING TORQUE FOR CRUSHING PLATE

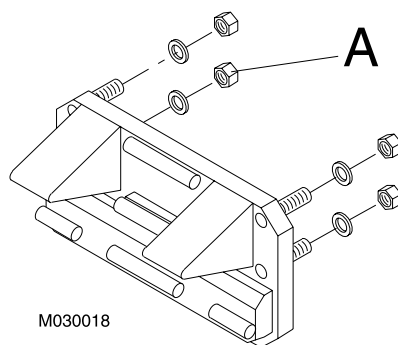

Item	Welding tool
Repair of parent, installation of crushing plate	MIG-wire, DIN 8559: SG 2
	Welding rod, DIN 1913: E 51 53 B 10
Hardfacing	MIG-wire, DIN 8555: SG 6 - 60
	Welding rod, DIN 8555: E 6 - 55
Crushing plate screws (A)	340 Nm

REMOVAL OF CRUSHING PLATE



Welding must occur in a workshop with proper welding tools. If you must weld the crusher when it is installed in carrier, consult your carrier dealer for precautions during welding.

Support the crusher jaw to prevent it from closing unexpectedly during maintenance.

1. Position the attachment on level ground.
2. Support the crusher jaw.
3. Remove hex nuts and washers.
4. Cut off the worn part by carbon arc gouging or by gas cutting at the base. Note: Connect earth cable to the part to be repaired.
5. Repair parent by filling it with welding rod, and finish the surface by grinding.

6. Make edge preparation on the body side.

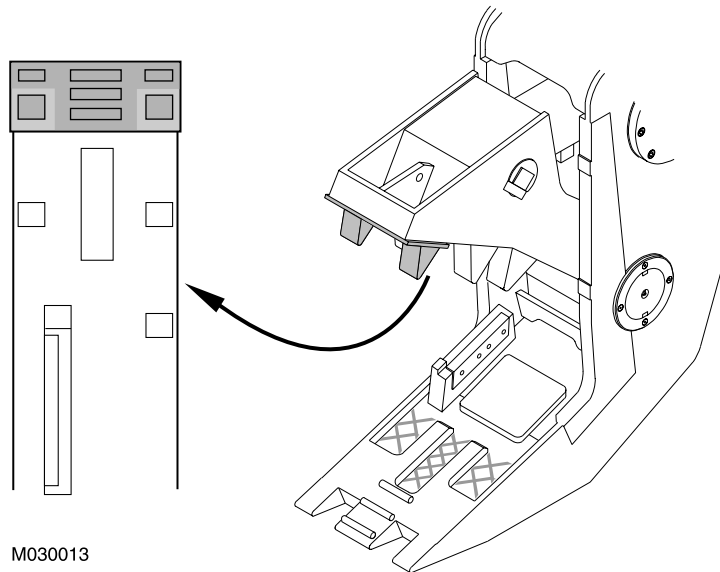

INSTALLATION OF CRUSHING PLATE

1. Fix the crushing plate properly into place.
2. Install washers and hex nuts. Torque parts to the specified setting.
3. Tack the new crushing plate with welding rod. Note: Connect earth cable to the part to be repaired.
4. Check that the plate is installed properly.
5. Preheat the jaw and the part to +100...+150 °C.
6. Perform welding.

6. TROUBLESHOOTING

6.1 MACHINE DOES NOT CRUSH

WORN CRUSHER TEETH

Perform new hardfacing. See “Hardfacing crusher jaw and teeth” on page 40.
If necessary, change tooth or crushing plate. See “Replacing crusher teeth” on page 42. See “Replacing crushing plate” on page 44.

DROP IN HYDRAULIC PRESSURE ON BASE MACHINE

Adjust pressure. See “Crusher specifications” on page 50.

OIL LEAKAGE WITHIN CYLINDER

The attachment must be serviced in an authorized Rammer service shop.

6.2 MACHINE DOES NOT CUT

WORN CUTTING BLADES

Turn over the cutting blades and adjust. If necessary, change the cutting blades. See “Turning and changing cutting blades” on page 37.

CUTTING BLADE DOES NOT FIT PROPERLY ONTO THE CUTTER BASE

Refit and tighten with bolts. See “Turning and changing cutting blades” on page 37.

INCORRECT CLEARANCE BETWEEN THE BLADES AND BASE

Check the clearance and adjust. See “Turning and changing cutting blades” on page 37.

DROP IN HYDRAULIC PRESSURE ON BASE MACHINE

Adjust pressure. See “Crusher specifications” on page 50.

OIL LEAKAGE WITHIN CYLINDER

The attachment must be serviced in an authorized Rammer service shop.

6.3 CRUSHER JAW DOES NOT MOVE

MALFUNCTION IN EXCAVATOR HYDRAULIC SYSTEM

Check the operation of auxiliary circuit.

BALL VALVES MAY BE CLOSED

Open the ball valves.

CRUSHER JAW MAY BE BLOCKED

Remove obstacles.

OIL LEAKAGE WITHIN CYLINDER

The attachment must be serviced in an authorized Rammer service shop.

CYLINDER ROD IS BENT

The attachment must be serviced in an authorized Rammer service shop.

6.4 EXCESSIVE MOVING

WORN PINS AND BUSHINGS

Change parts. The attachment must be serviced in an authorized Rammer service shop.

6.5 OIL LEAKAGE

OIL LEAKAGE AT HOSE END

Check the hose end and tighten.

OIL LEAKAGE AT SWIVEL JOINT

The attachment must be serviced in an authorized Rammer service shop.

CYLINDER SEALS ARE DAMAGED

The attachment must be serviced in an authorized Rammer service shop.

SPECIFICATIONS

1. CRUSHER SPECIFICATIONS

1.1 TECHNICAL SPECIFICATIONS RB 42 N

Item	Specification
Working weight ^a	3340 kg (7360 lb)
Max. jaw opening	1160 mm (44 in)
Max. cutting force	2330 kN (523 700 lbf)
Max. crushing force	1220 kN (274 200 lbf)
Max. operating pressure	320 bar (4640 psi)
Oil flow (recom.)	250 l/min (66 gal/min)
Cylinder connections	SAE JIC 1 5/8-12
Mouth depth	1090 mm (43 in)
Cutting blade length	280 mm (11 in)
Optimum oil temperature	+40 - +60°C (+104 - +140°F)
Allowed oil temperature range	-20 - +80°C (-4 - +176°F)
Optimum oil viscosity at operating temperature	30-60 cSt
Allowed oil viscosity range	20-1000 cSt
Carrier weight ^b	24 - 42 t

- a. Includes average mounting bracket
- b. Check carrier's lifting capacity from carrier manufacturer

1.2 MAIN DIMENSIONS RB 42 N

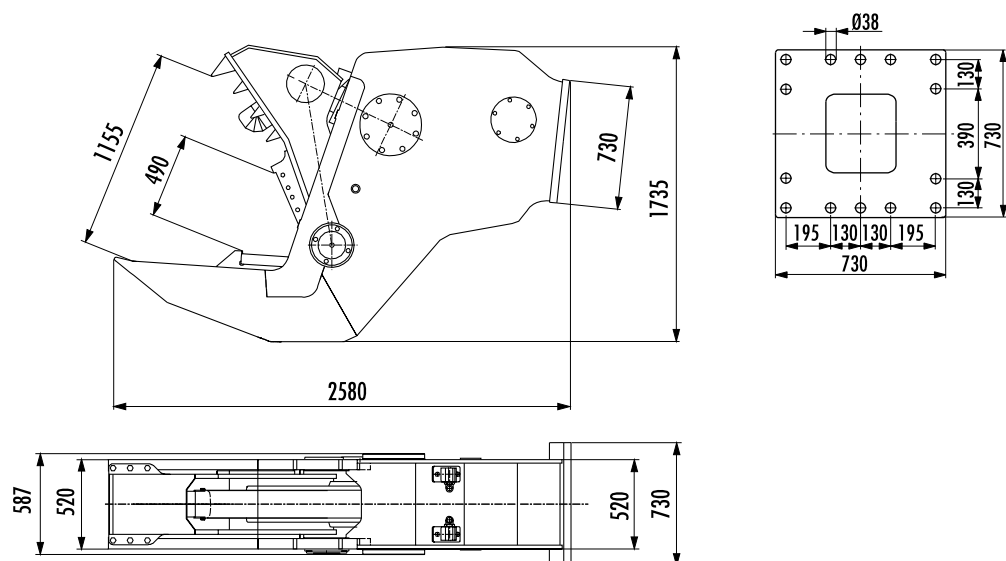

M040010

Sandvik Tamrock Corp., Breakers Lahti
Taivalkatu 8, P.O. Box 165, FIN-15101 Lahti, Finland
Phone Int. +358 205 44 161, Telefax Int. +358 205 44 160
www.rammer.com