

ENG 9/03

**PARTS MANUAL**  
**PMRC26NENG.903**

**CUTTER-CRUSHER**  
**RAMMER RC 26 N**

**Serial No.**  
**RC26NRE0040-UP**

---

## TABLE OF CONTENTS

1. Cylinder RC 26 N . . . . .	4
2. Hydraulics RC 26 N . . . . .	6
3. Brake RC 26 N . . . . .	8
4. Hydraulic motor RC 26 N . . . . .	9
5. Slew lock RC 26 N . . . . .	10
6. Slewing ring RC 26 N . . . . .	11
7. Body parts RC 26 N . . . . .	12
8. Wear items RC 26 N . . . . .	14

---

## GENUINE RAMMER SPARE PARTS

Rammer genuine spare parts are designed and manufactured by using the latest technological knowledge and engineering skills. Rammer spare parts are made of the best available materials with the most advanced manufacturing techniques.

It is important that you use only genuine Rammer spare parts, to ensure easy operation, maintenance and repair of the product. Please note that eventual warranty claims will be handled only if you have used genuine Rammer parts in your Rammer.

## LOCATION OF THE SERIAL NUMBER

It's important to make correct reference to the serial number of the product when ordering spare parts. Identification of serial number is the only proper means of maintaining and identifying parts for a specific product. The location of equipment serial number is pointed in "Operation and maintenance" manual.

## SPARE PART ORDERS

Quick spare part deliveries are secured by exact orders.

### Required information:

- Name of customer and contact person
  - Order number (when available)
  - Delivery address
  - Mode of delivery (air mail etc.)
  - Required delivery date
  - Invoicing address
  - Model and serial number of the product
  - Name, number and required amount of spare parts
-

---

---

# **PARTS**

---

## CYLINDER RC 26 N

### 1. CYLINDER RC 26 N

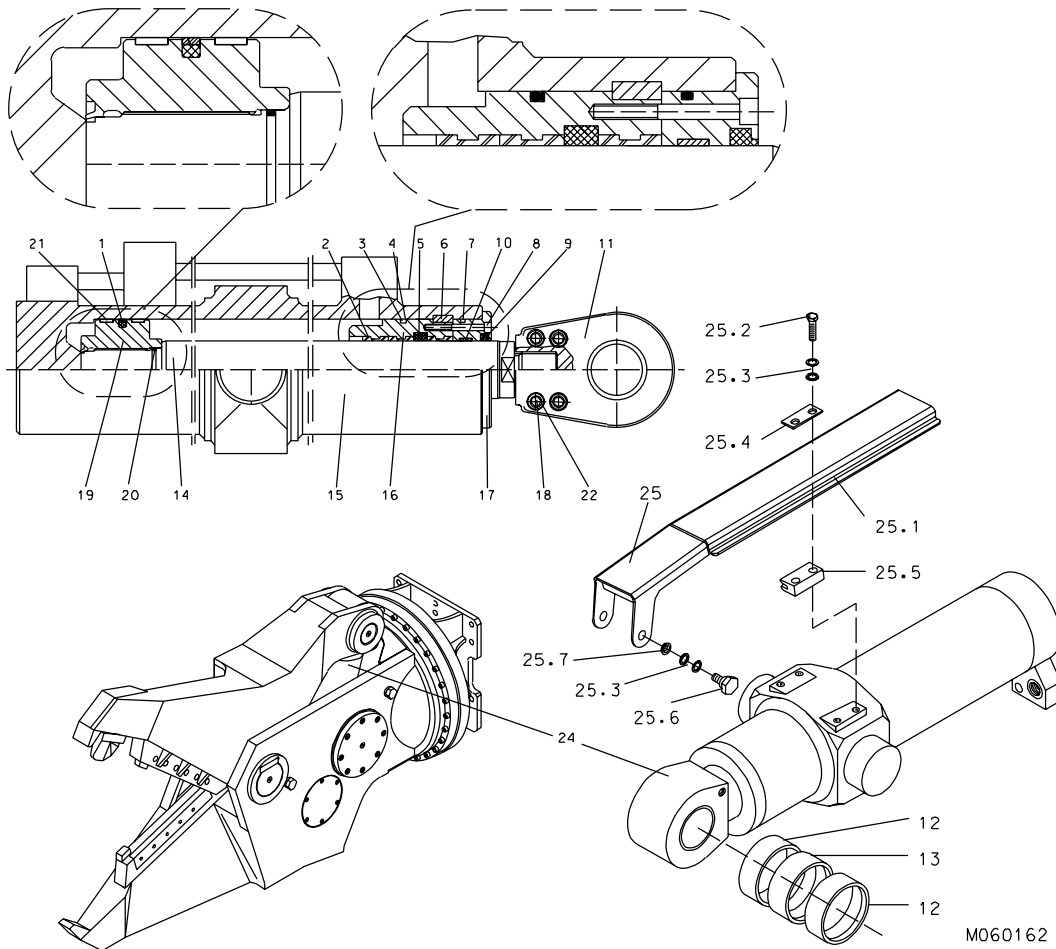

Item	Description	Part no.	Specification	Note	Qty
24	Hydraulic cylinder (incl. parts 1-22 and 25)	951264			1
1	Seal	903401	D200		1
2	Steering ring	902602	D110		3
3	O-ring	902697	D190		1
4	Supporting ring	902698	D200		1
5	Seal	902605			1
6	Lock ring	902699			1
7	O-ring	951244	D194		1
8	Hex. socket screw	91107	M12x90-8.8 DIN 912		4
9	Wiper	951015	D110		1
10	Slide ring	902523	D110		1
11	Swivel bushing	902610			1
12	Sliding bearing	902611	WB800 100/105-50		2
13	Sliding bearing	902612	WB800 100/105-30		1
14	Piston rod	951014			1
15	Cylinder body	902702			1

**CYLINDER RC 26 N**

<b>Item</b>	<b>Description</b>	<b>Part no.</b>	<b>Specification</b>	<b>Note</b>	<b>Qty</b>
16	Guide	902703			1
17	Ring	902704			1
18	Hex. socket screw	902706	M16x110-8.8 DIN 912		4
19	Piston	951017			1
20	O-ring	90025	D85		1
21	Guide	951016			2
22	Lock washer	90597	M16 NORD-LOCK		8
23	Seal set for cylinder	950348			1
25	Cylinder shield (incl. parts 25.1-25.7)	140513			1
25.1	Shield plate	154445			1
25.2	Hex. screw	90544	M16x60-8.8 ISO 4014		4
25.3	Lock washer	90597	M16 NORD-LOCK		6
25.4	Support plate	140507			2
25.5	Slide plate	111811			2
25.6	Hex. screw	90514			2
25.7	Bushing	140511			2

## 2. HYDRAULICS RC 26 N

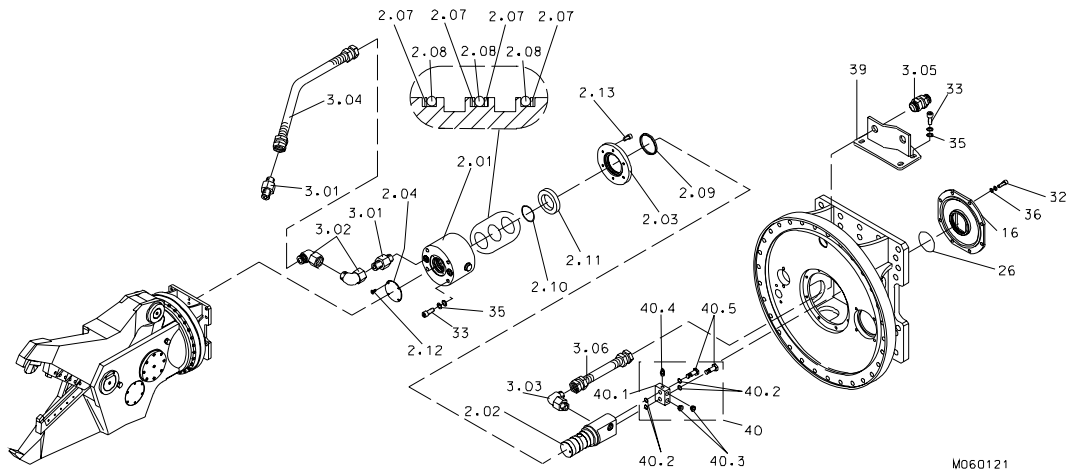

M060121

Item	Description	Part no.	Specification	Note	Qty
2.01	Body	140301			1
2.02	Spool	140300			1
2.03	Cover	140048			1
2.04	Cover	140047			1
2.07	Supporting ring	901303			4
2.08	O-ring	901302	D72		3
2.09	Wiper	911017	D90		1
2.10	Lock ring	901307			1
2.11	Ball bearing	901305			1
2.12	Hex. socket screw	901306			4
2.13	Hex. socket screw	90501	M10x20-8.8 DIN 912		6
3.01	Adapter	901583	F40XS25-1		4
3.02	Elbow	901602	C6XS25		4
3.03	Elbow	901585	C40XS25-1		2
3.04	Hose assembly	901603			2
3.05	Bulkhead union	90470			2
3.06	Hose assembly	902124			2
16	Slew stopper	140114			1
26	O-ring	901316			1
32	Hex. socket screw	900046	M12x35-8.8 DIN 912		8
33	Hex. socket screw	91100	M16x40-8.8 DIN 912		8
35	Lock washer	90597	M16 NORD-LOCK		8
36	Lock washer	91012	M12 NORD-LOCK		8
39	Hose clamp	140504			1
40	Valve (incl. parts 40.1-40.5)	152364			1

---

<b>Item</b>	<b>Description</b>	<b>Part no.</b>	<b>Specification</b>	<b>Note</b>	<b>Qty</b>
40.1	Valve body	152121			1
40.2	Usit-ring	911009	U27.2-36-2		4
40.3	Flange plug	90401	R3/4		2
40.4	Valve	950307			1
40.5	Screw	951030	G3/4		2

**3. BRAKE RC 26 N**

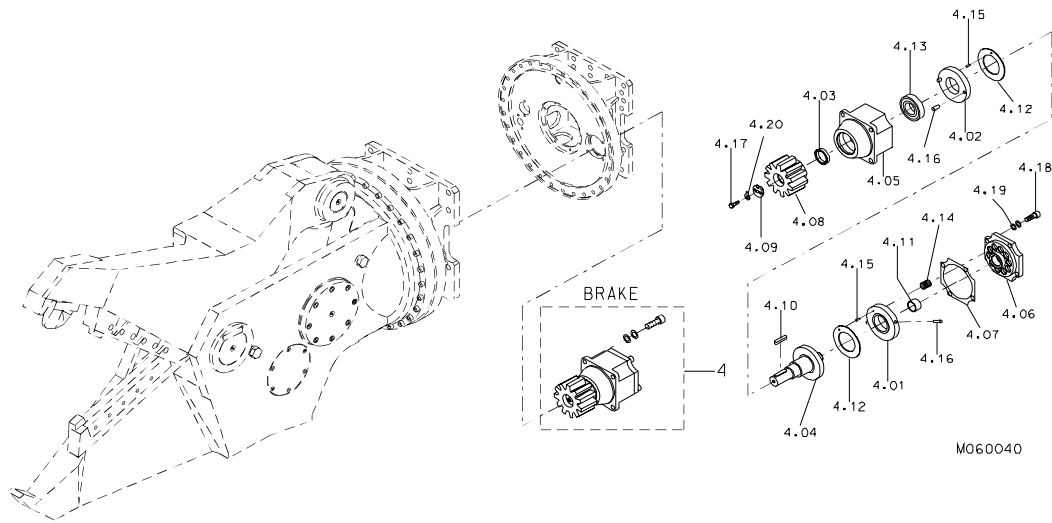

Item	Description	Part no.	Specification	Note	Qty
4	Brake (incl. parts 4.01-4.20)	140292			1
4.01	Supporting ring	140195			1
4.02	Supporting ring	140196			1
4.03	Bushing	140197			1
4.04	Shaft	140198			1
4.05	Body	140294			1
4.06	Cover	140293			1
4.07	Spacer plate	140193			2
4.08	Cylindrical gear	140014			1
4.09	Washer	140052			1
4.10	Key	901482			1
4.11	Bush	901483			1
4.12	Plate	901484			2
4.13	Ball bearing	901485			1
4.14	Spring	901486			10
4.15	Parallel pin	901487			2
4.16	Parallel pin	901488			4
4.17	Hex. screw	90570	M8x25-8.8 DIN 933		1
4.18	Hex. socket screw	900046	M12x35-8.8 DIN 912		8
4.19	Lock washer	91012	M12 NORD-LOCK		8
4.20	Washer	902925	DIN 93-8.4-St		1



4. HYDRAULIC MOTOR RC 26 N

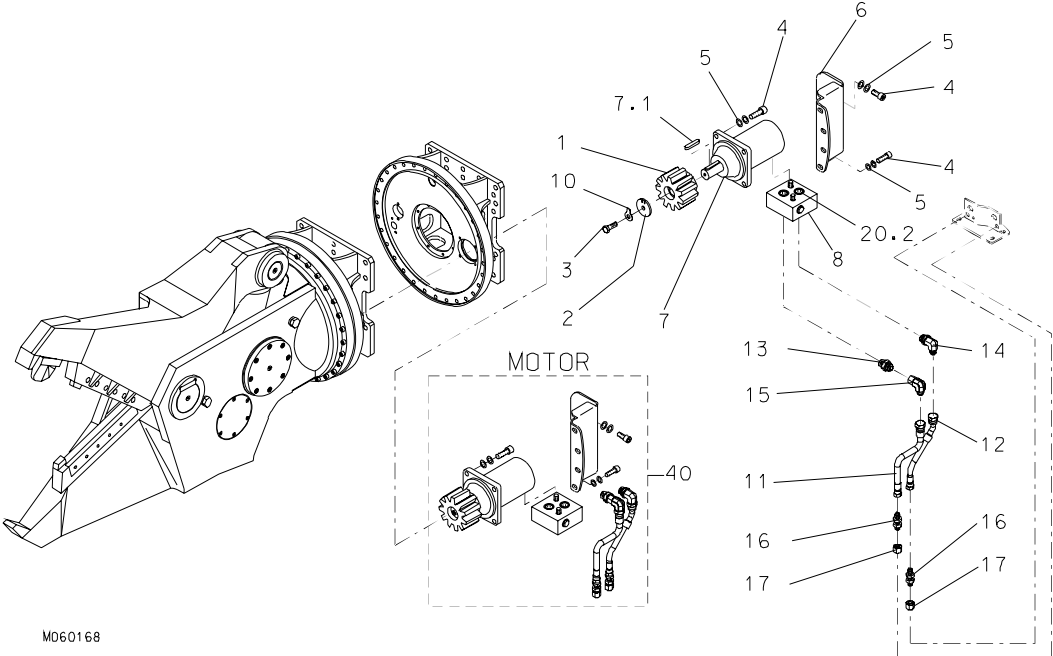

MD60168

Item	Description	Part no.	Specification	Note	Qty
40	Hydraulic motor (incl. parts 1-17)	154444			1
1	Cylindrical gear	154143			1
2	Washer	153332			1
3	Hex. screw	90591	M8x20-8.8 ISO 4017		1
4	Hex. socket screw	900046	M12x35-8.8 DIN 912		10
5	Lock washer	91012	M12 NORD-LOCK		10
6	Casing	140495			1
7	Hydraulic motor (incl. part 7.1)	951451			1
7.1	Key	903156			1
8	Pressure adjusting valve (incl. part 20.2)	901320			1
10	Washer	902925	DIN 93-8.4-St		1
11	Hose assembly	152129			1
12	Hose assembly	152128			1
13	Connector	950038			1
14	Elbow	903029			1
15	Elbow	902728			1
16	Bulkhead union	93239			2
17	Cap	93234			2
20.2	O-ring	903190	D23		2

**5. SLEW LOCK RC 26 N**

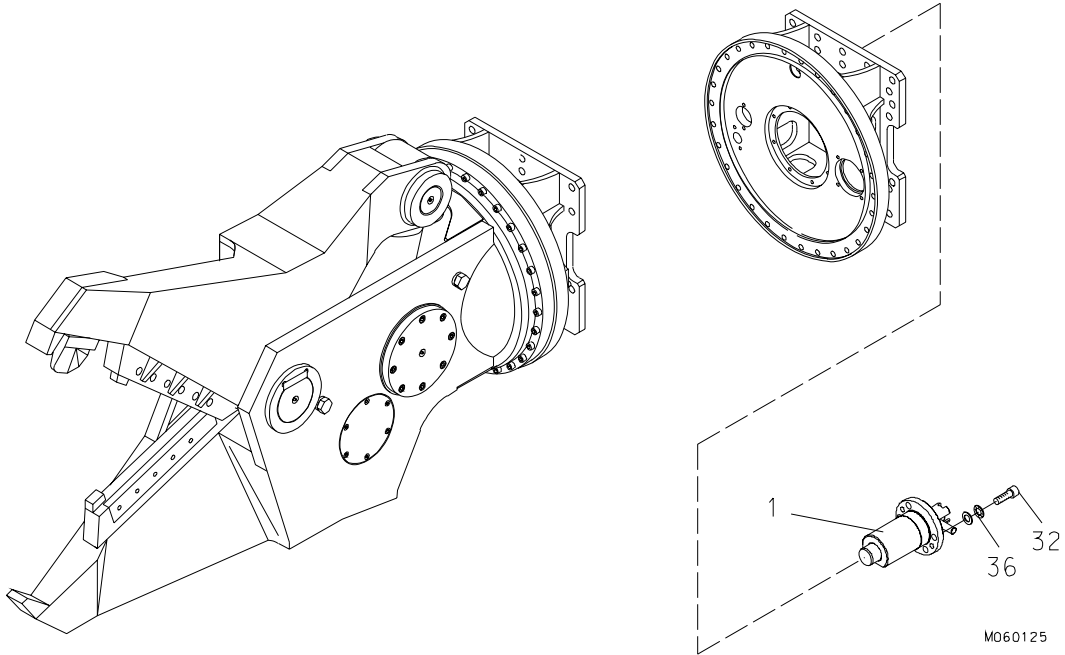

Item	Description	Part no.	Specification	Note	Qty
1	Slew lock	152694			1
32	Hex. socket screw	900046	M12x35-8.8 DIN 912		4
36	Lock washer	91012	M12 NORD-LOCK		4

6. SLEWING RING RC 26 N

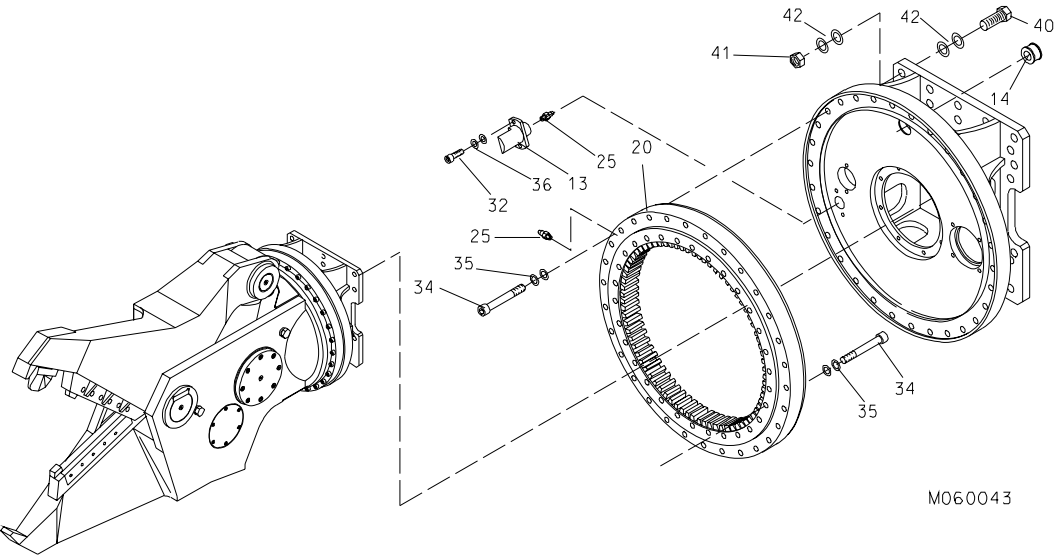

Item	Description	Part no.	Specification	Note	Qty
13	Guide	140051			1
14	Rubber plug	400491			1
20	Slewing ring	901318			1
20.1	Seal set for slewing ring	902646			1
25	Grease nipple	90204	A M10x1		2
32	Hex. socket screw	900046	M12x35-8.8 DIN 912		2
34	Hex. socket screw	902915			60
35	Lock washer	90597	M16 NORD-LOCK		60
36	Lock washer	91012	M12 NORD-LOCK		2
40	Hex. screw	90589	M24x110-12.9 DIN 931		14
41	Lock nut	90507	M24-12 DIN 985		14
42	Washer	90511	25 DIN 6916		28

**7. BODY PARTS RC 26 N**

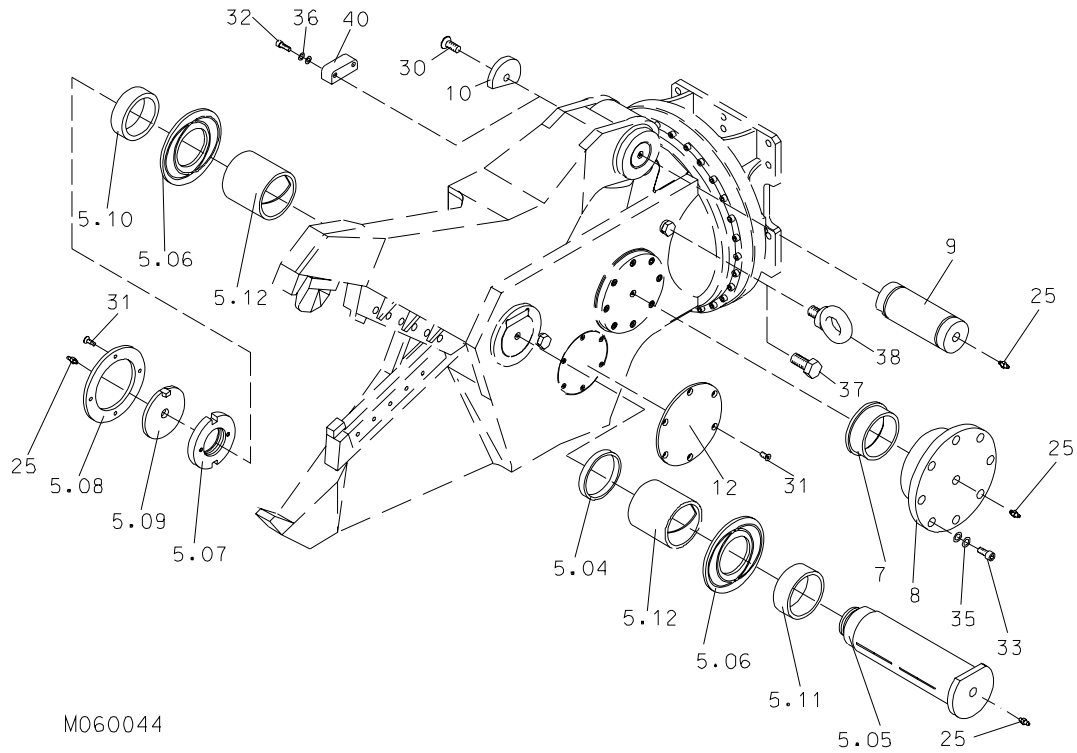

M060044

Item	Description	Part no.	Specification	Note	Qty
5.04	Bushing	140345			1
5.05	Shaft	140119			1
5.06	Spacer plate	140118			2
5.07	Axle nut	140117			1
5.08	Cover holder	140044			1
5.09	Cover	140042			1
5.10	Bush	140115			1
5.11	Bush	140116			1
5.12	Bush	140121			2
7	Bush	140038			2
8	Cap	140035			2
9	Shaft	140039			1
10	Cover	140040			1
12	Cover	140027			2
25	Grease nipple	90204	A M10x1		5
30	Hex. socket screw	901287	M20x40-8.8 DIN 7991		1
31	Hex. socket screw	901286	M10x25-8.8 DIN 7991		12
32	Hex. socket screw	900046	M12x35-8.8 DIN 912		16
33	Hex. socket screw	91100	M16x40-8.8 DIN 912		16
35	Lock washer	90597	M16 NORD-LOCK		16
36	Lock washer	91012	M12 NORD-LOCK		16

**BODY PARTS RC 26 N**

---

<b>Item</b>	<b>Description</b>	<b>Part no.</b>	<b>Specification</b>	<b>Note</b>	<b>Qty</b>
37	Hex. screw	900026	M30x40-8.8 DIN 933		4
38	Lifting eye	90705	M30 DIN 580		2
40	Plate	140524			1
43	Label set	141051			1

**8. WEAR ITEMS RC 26 N**

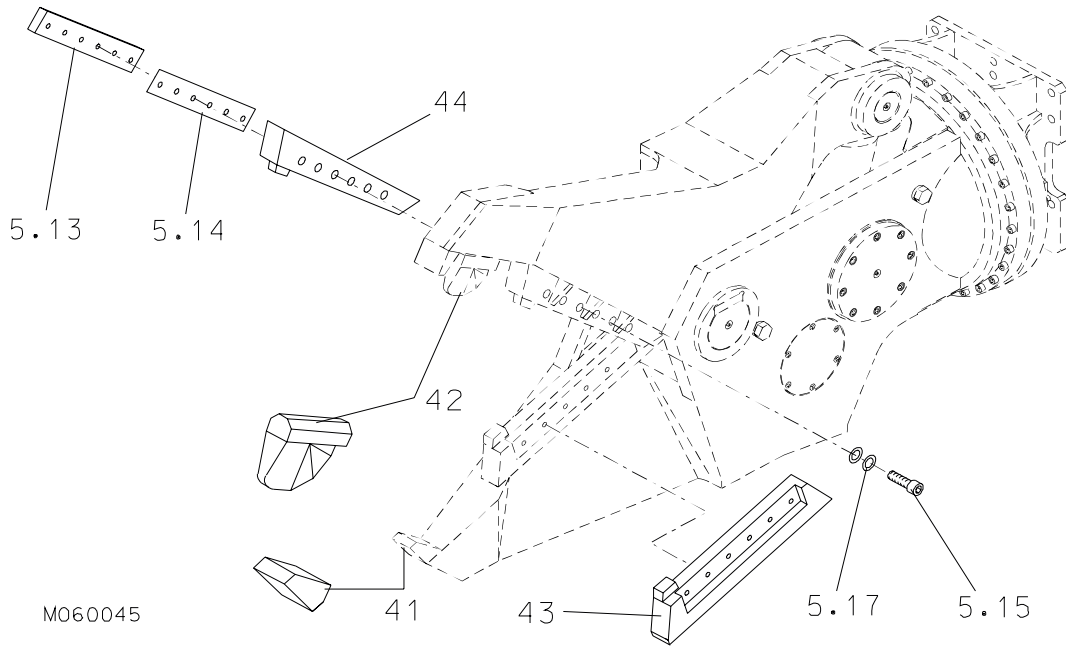

Item	Description	Part no.	Specification	Note	Qty
5.13	Cutting blade	140085			2
5.14	Shim plate	140108			x
5.15	Hex. socket screw	901309	M16x55-8.8 DIN 912		12
5.17	Lock washer	90597	M16 NORD-LOCK		12
41	Front tooth	140004			2
42	Breaking tooth	140025			1
43	Cutting blade seat	110105			1
44	Cutting blade seat	110106			1



**Sandvik Tamrock Corp., Breakers Lahti**  
**Taivalkatu 8, P.O. Box 165, FIN-15101 Lahti, Finland**  
**Phone Int. +358 205 44 161, Telefax Int. +358 205 44 160**  
**[www.rammer.com](http://www.rammer.com)**

27-36-14021-42-200-385  
27-36-14021-45-96-294