

Original instructions

**Rammer**<sup>®</sup>

ENG 1/14

**PARTS MANUAL**  
**PM315SPFENG.114**

**HYDRAULIC HAMMER**  
**RAMMER 315**

**STD**

**PIN**

**FLANGE**

**Serial No.**

**I5181413-UP**

**R A M M E R   H I T S   H A R D E R**

---

## TABLE OF CONTENTS

1. Housing unit . . . . .	4
2. Accumulator . . . . .	5
3. Pressure adjusting valve . . . . .	6
4. Body parts . . . . .	8
5. Mounting . . . . .	10
6. Tool . . . . .	11
7. Seal set . . . . .	12
8. Service kit . . . . .	14

---

### GENUINE RAMMER SPARE PARTS

Rammer genuine spare parts are designed and manufactured by using the latest technological knowledge and engineering skills. Rammer spare parts are made of the best available materials with the most advanced manufacturing techniques.

It is important that you use only genuine Rammer spare parts, to ensure an easy operation, maintenance and repair of the product. Please note that eventual warranty claims will be handled only if you have used genuine Rammer parts.

### LOCATION OF THE SERIAL NUMBER

It is important to refer to the serial number of the product when ordering spare parts. The identification of serial number is the only proper means of maintaining and identifying parts for a specific product. The location of the equipment serial number is pointed in “Operation and maintenance” manual.

### SPARE PART ORDERS

Quick spare part deliveries are ensured by exact orders.

#### Required information:

- Name of customer and contact person
  - Order number (when available)
  - Delivery address
  - Mode of delivery (air mail, etc.)
  - Required delivery date
  - Invoicing address
  - Model and serial number of the product
  - Name, number and required amount of spare parts
-

---

# PARTS

---

# 1. HOUSING UNIT

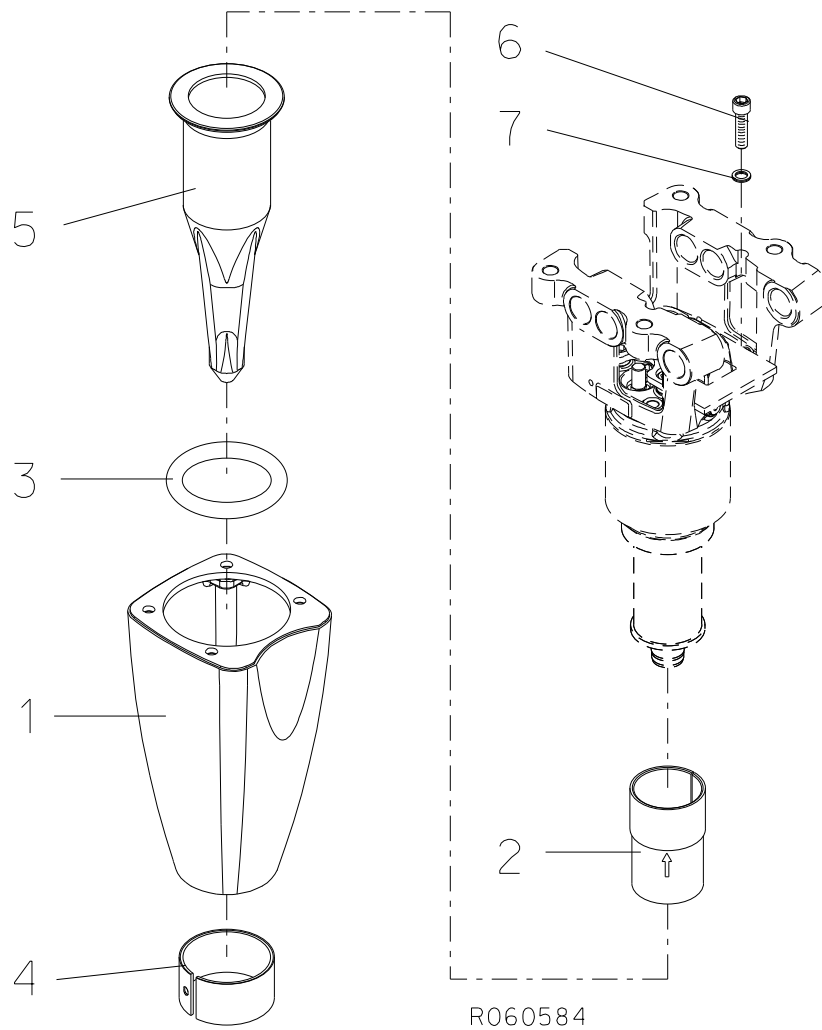

Item	Description	Part no.	Specification	Note	Qty
1	Housing	154994			1
2	Lower tool bushing	113073			1
3	Tool retaining ring	113078			1
4	Guide ring	157122			1
5	Pyramid tool	N123S1			1
6	Hex. socket screw	91006	M16x60-8.8 ISO 4762		4
7	Lock washer	90597	M16 NORD-LOCK		4
10	Label set (incl. part 10.1)	170452			1
10.1	Safety label set	169400	english		1

## 2. ACCUMULATOR

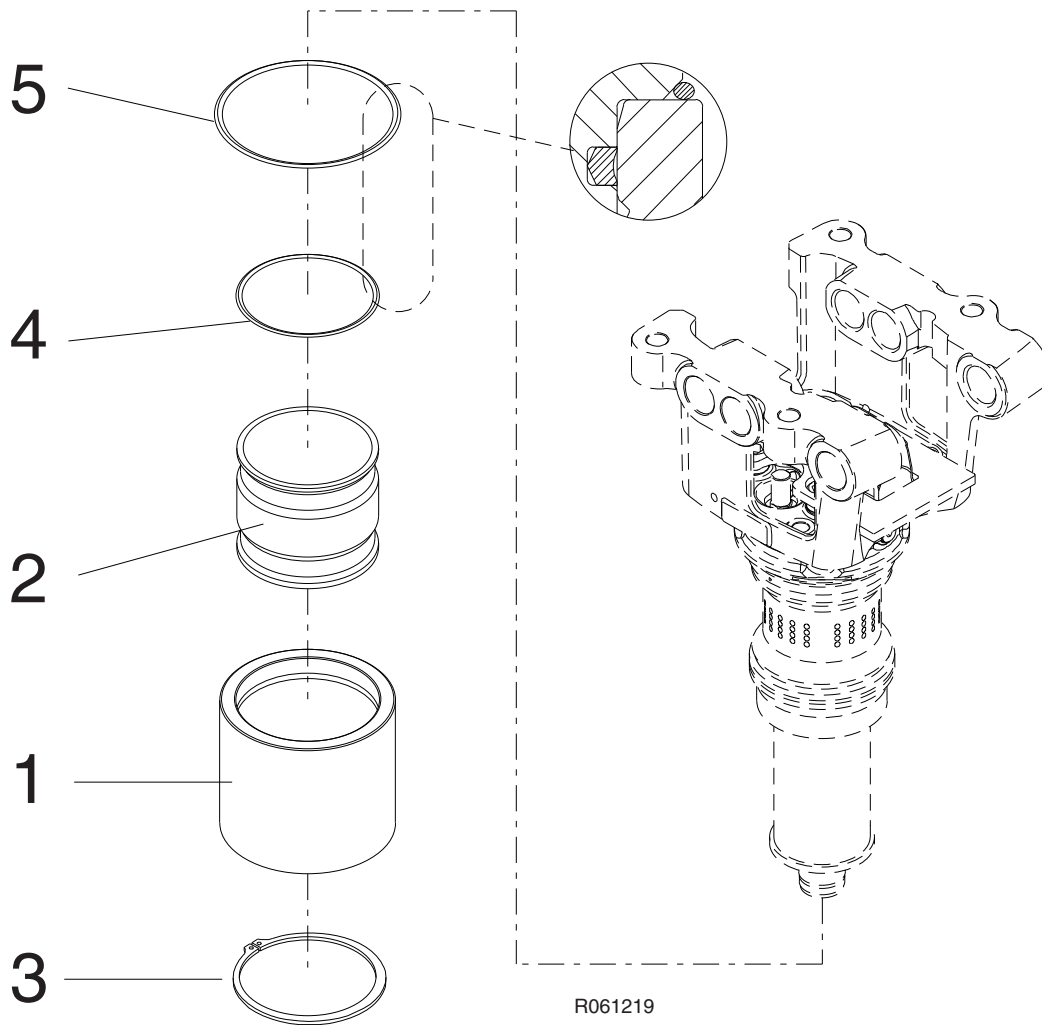

Item	Description	Part no.	Specification	Note	Qty
1	Accumulator cover	113053			1
2	Membrane	154759			1
3	Retaining ring	950103	160x4 DIN 471		1
4	Seal	953599		*	1
5	O-ring	901130	D160	*	1
	*) Are included in seal set				

**3. PRESSURE ADJUSTING VALVE**

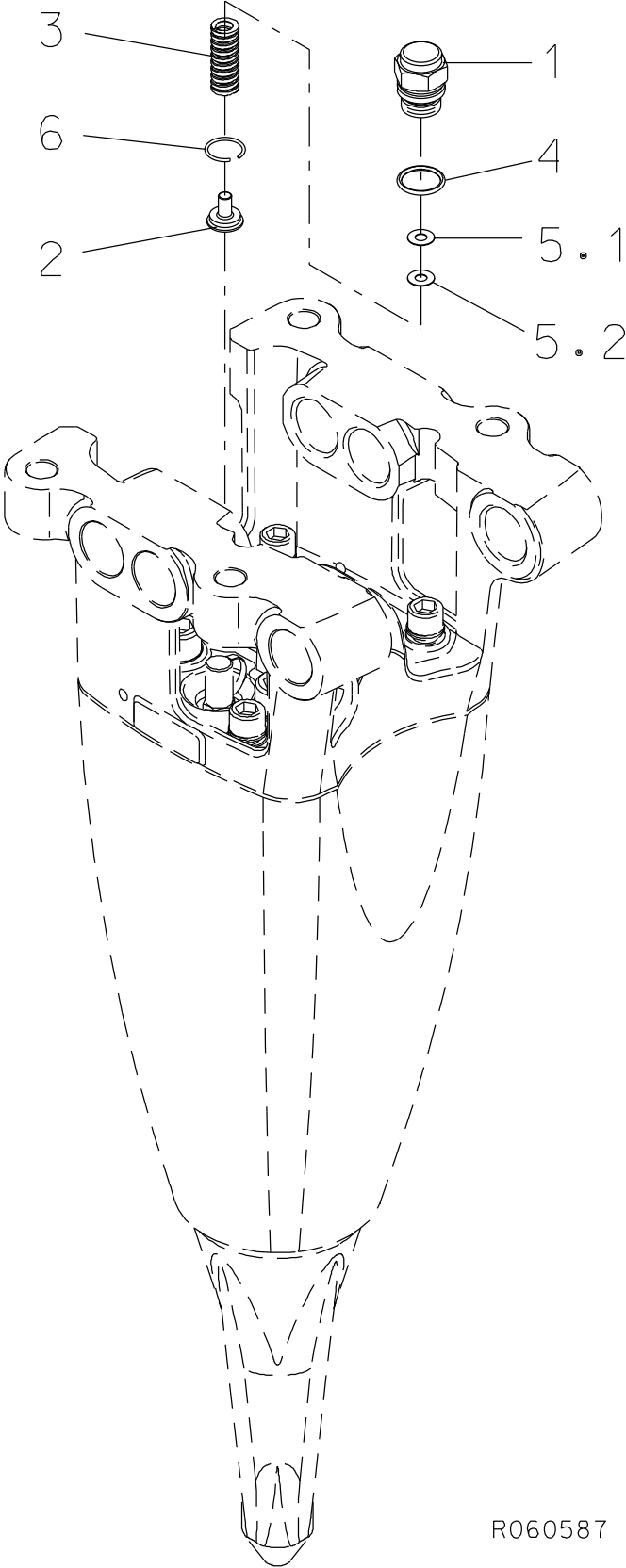

R060587

---

Item	Description	Part no.	Specification	Note	Qty
1	Spring housing	113091			1
2	Spring guide	113006			1
3	Spring	90114	9-1208-26 DANLY		1
4	O-ring	90015	D26	*	1
5.1	Shim plate	41639	S=0.5		x
5.2	Shim plate	41640	S=1		x
6	Spring ring	902988	B25 DIN 7993		1
	*) Are included in seal set				

### 4. BODY PARTS

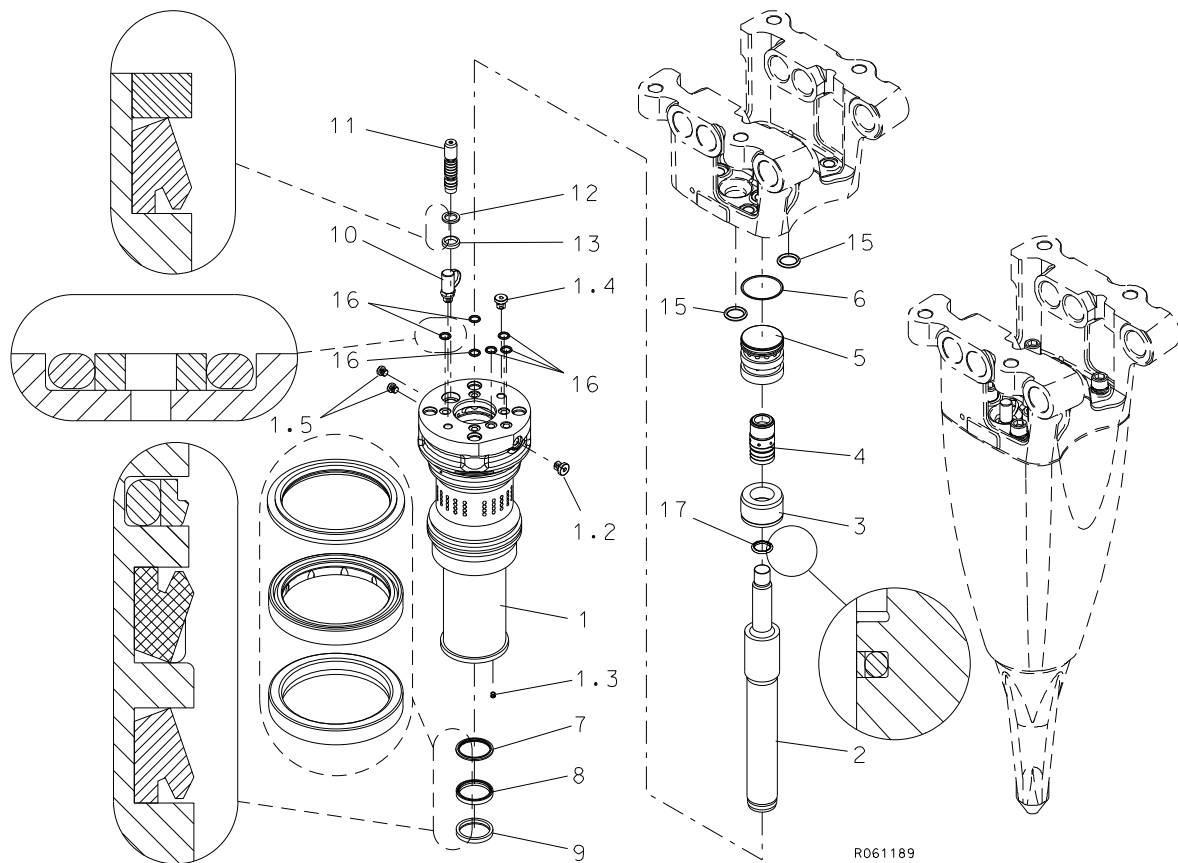

Item	Description	Part no.	Specification	Note	Qty
1	Cylinder (incl. parts 1.2-1.5)	154634			1
1.2	Flange plug	90403	R1/4		1
1.3	Plug	903419			1
1.4	Flange plug	41658	R1/4		1
1.5	Flange plug	93203	R1/8		2
2	Piston	154732			1
3	Steering ring	163180			1
4	Distributor	113033			1
5	Slide ring	113023			1
6	O-ring	90014	D65	*	1
7	Seal	952245		*	1
8	Seal	952221		*	1
9	Seal	952248		*	1
10	Accumulator filling valve	903408			1



---

Item	Description	Part no.	Specification	Note	Qty
11	Spool	113084			1
12	Washer	157117			1
13	Seal	951479	D18	*	1
15	O-ring	90017	D34	*	2
16	Seal	161395	D14	*	6
17	Seal	954045	D32	*	1
	*) Are included in seal set				

## 5. MOUNTING

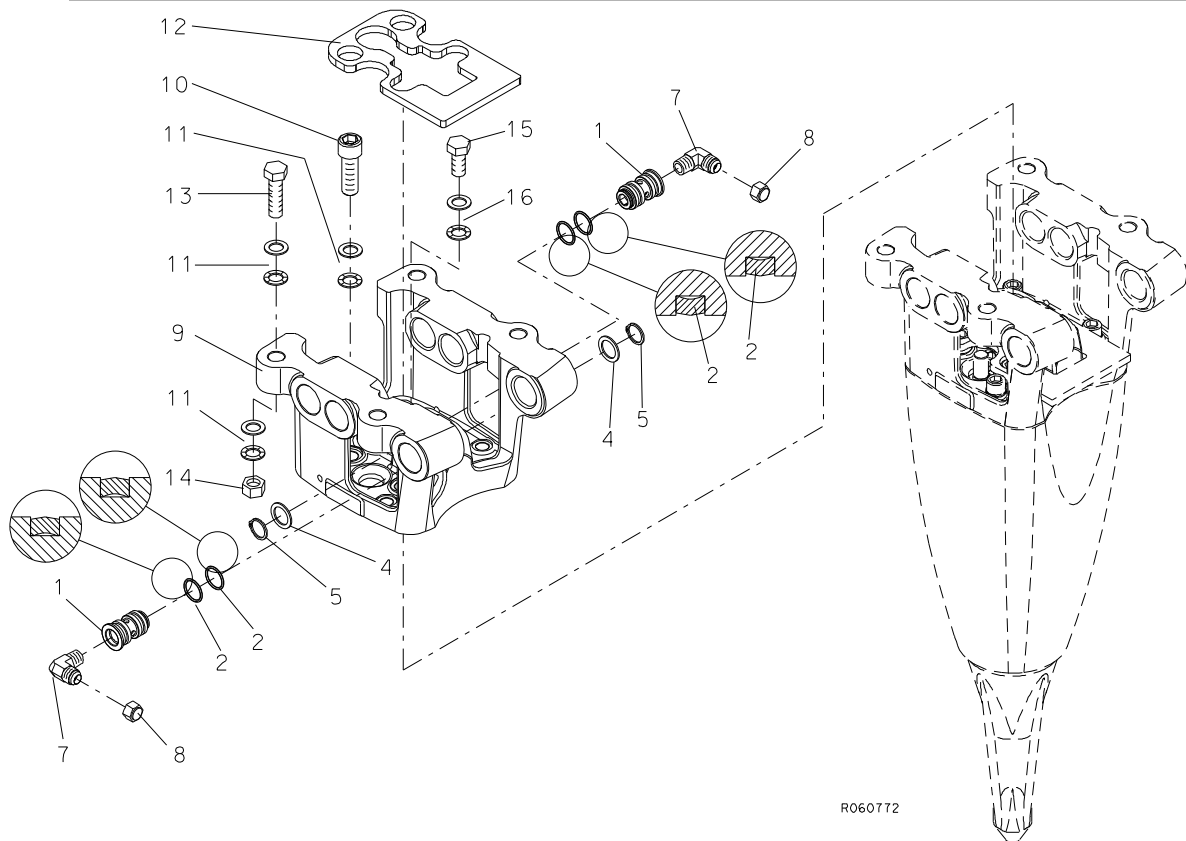

Item	Description	Part no.	Specification	Note	Qty
1	Manifold	113058			2
2	Seal	952536		*	4
4	Support plate	903395	SS25x36x2.0 DIN 988	*	2
5	Retaining ring	950188	25x2 DIN 471	*	2
7	Elbow	951333			2
8	Cap	915030			2
9	Mounting bracket	156874			1
10	Hex. socket screw	91064	M20x60-8.8 ISO 4762		4
11	Lock washer	91010	M20 NORD-LOCK		12
12	Rubber plate	157187			1
13	Hex. screw	91022	M20x90-8.8 ISO 4014		4
14	Hex. nut	91017	M20-8 ISO 4032		4
15	Hex. screw	950329	M10x12-8.8 ISO 4017		1
16	Lock washer	91037	M10 NORD-LOCK		1
	*) Are included in seal set				

6. TOOL

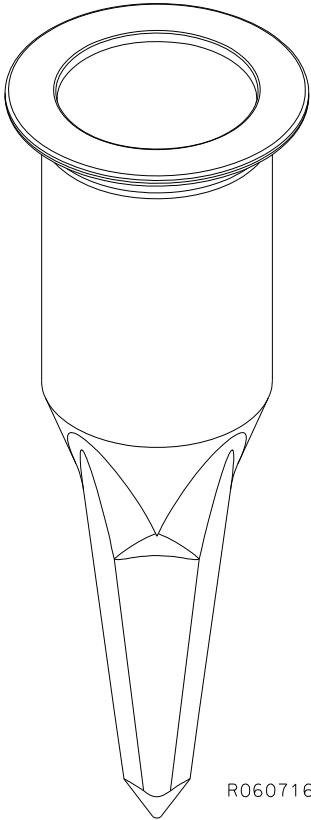

R060716

Item	Description	Part no.	Specification	Note	Qty
1	Pyramid	N123S1	L = 520 mm, W = 18.1 kg D = 131 mm		1

## 7. SEAL SET

Seal set 157279

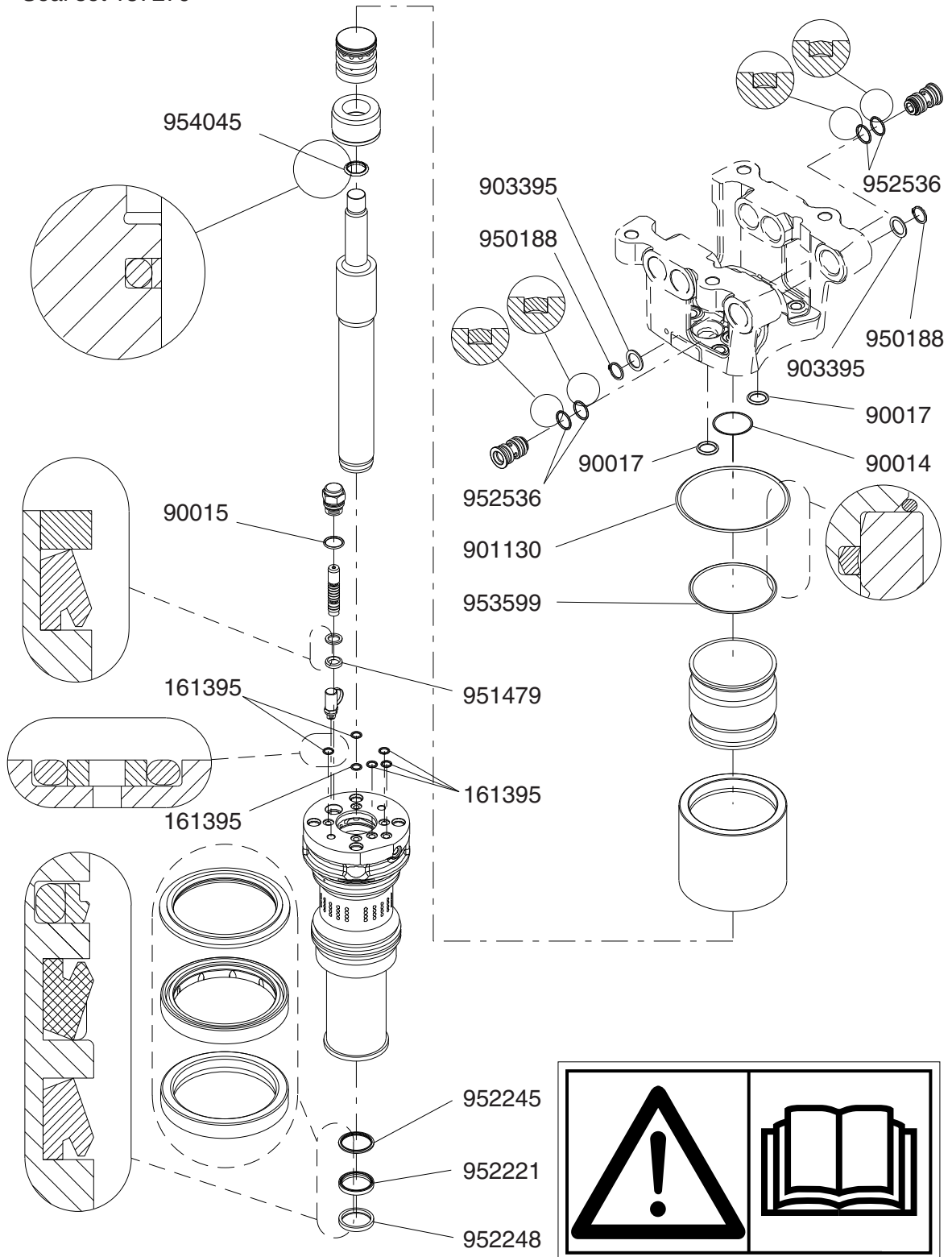

This summary only indicates the position of the seals. It must NOT be used as assembly instruction. Read the manual.

R061218

Item	Description	Part no.	Specification	Note	Qty
Kit	Seal set (incl. parts 1-14)	157279			1
1	O-ring	90015	D26		1
2	Seal	952536			4
3	Seal	953599			1
4	O-ring	90014	D65		1
5	Seal	952245			1
6	Seal	952221			1
7	Seal	951479	D18		1
8	Seal	161395	D14		6
9	O-ring	901130	D160		1
10	O-ring	90017	D34		2
11	Support plate	903395	SS25x36x2.0 DIN 988		2
12	Retaining ring	950188	25x2 DIN 471		2
13	Seal	952248			1
14	Seal	954045	D32		1

## 8. SERVICE KIT

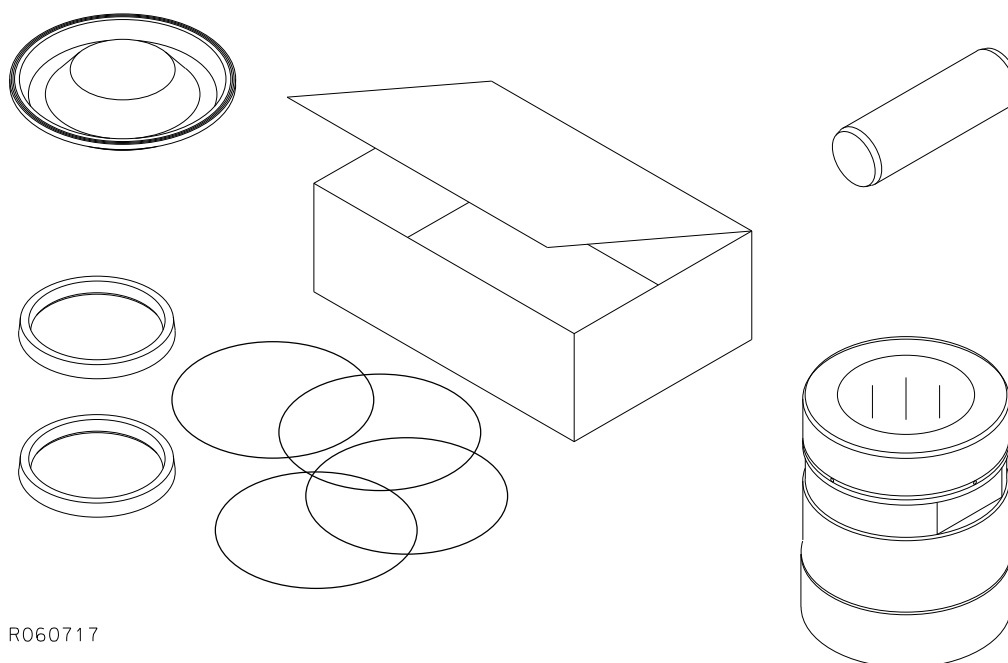

R060717

Item	Description	Part no.	Specification	Note	Qty
Kit	Servicekit (incl. parts 1 - 4)	K11N15			1
1	Lower tool bushing	113073			1
2	Tool retaining ring	113078			1
3	Membrane	154759			1
4	Seal set	157279			1





Sandvik Mining and Construction Oy, Breakers Lahti  
Taivalkatu 8, P.O. Box 165, FI-15101 Lahti, Finland  
Phone Int. +358 205 44 151, Telefax Int. +358 205 44 150  
[www.rammer.com](http://www.rammer.com)